

# **BUNN**<sup>®</sup> *ULTRA-2*

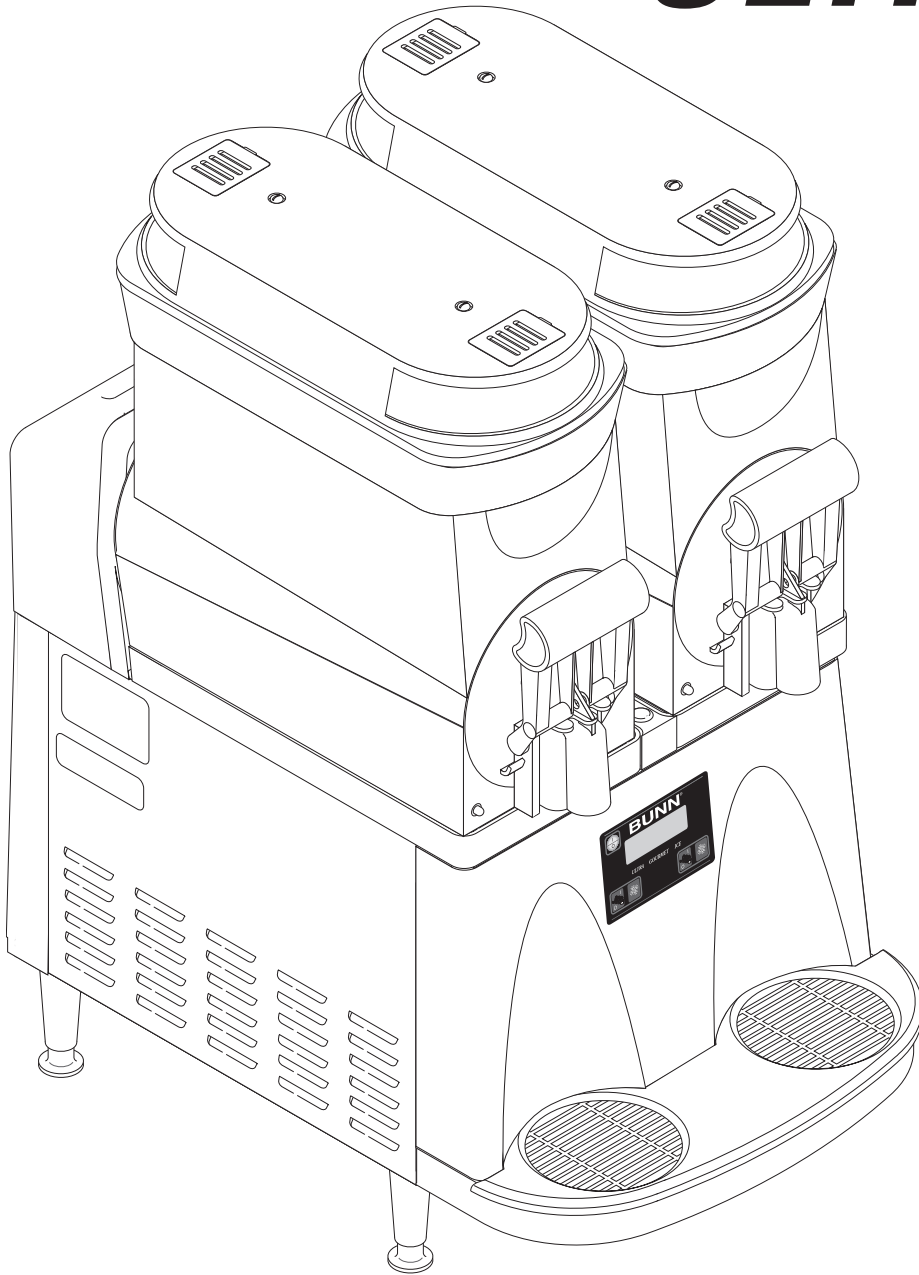

## **ILLUSTRATED PARTS CATALOG**

Designs, materials, weights, specifications, and dimensions for equipment or replacement parts are subject to change without notice.

### **BUNN-O-MATIC CORPORATION**

POST OFFICE BOX 3227

SPRINGFIELD, ILLINOIS 62708-3227

PHONE: (217) 529-6601 FAX: (217) 529-6644

## BUNN-O-MATIC COMMERCIAL PRODUCT WARRANTY

Bunn-O-Matic Corp. ("BUNN") warrants equipment manufactured by it as follows:

- 1) All equipment other than as specified below: 2 years parts and 1 year labor.
- 2) Electronic circuit and/or control boards: parts and labor for 3 years.
- 3) Compressors on refrigeration equipment: 5 years parts and 1 year labor.
- 4) Grinding burrs on coffee grinding equipment to grind coffee to meet original factory screen sieve analysis: parts and labor for 3 years or 30,000 pounds of coffee, whichever comes first.

These warranty periods run from the date of installation BUNN warrants that the equipment manufactured by it will be commercially free of defects in material and workmanship existing at the time of manufacture and appearing within the applicable warranty period. This warranty does not apply to any equipment, component or part that was not manufactured by BUNN or that, in BUNN's judgment, has been affected by misuse, neglect, alteration, improper installation or operation, improper maintenance or repair, damage or casualty. This warranty is conditioned on the Buyer 1) giving BUNN prompt notice of any claim to be made under this warranty by telephone at (217) 529-6601 or by writing to Post Office Box 3227, Springfield, Illinois 62708-3227; 2) if requested by BUNN, shipping the defective equipment prepaid to an authorized BUNN service location; and 3) receiving prior authorization from BUNN that the defective equipment is under warranty.

**THE FOREGOING WARRANTY IS EXCLUSIVE AND IS IN LIEU OF ANY OTHER WARRANTY, WRITTEN OR ORAL, EXPRESS OR IMPLIED, INCLUDING, BUT NOT LIMITED TO, ANY IMPLIED WARRANTY OF EITHER MERCHANTABILITY OR FITNESS FOR A PARTICULAR PURPOSE.** The agents, dealers or employees of BUNN are not authorized to make modifications to this warranty or to make additional warranties that are binding on BUNN. Accordingly, statements by such individuals, whether oral or written, do not constitute warranties and should not be relied upon.

If BUNN determines in its sole discretion that the equipment does not conform to the warranty, BUNN, at its exclusive option while the equipment is under warranty, shall either 1) provide at no charge replacement parts and/or labor (during the applicable parts and labor warranty periods specified above) to repair the defective components, provided that this repair is done by a BUNN Authorized Service Representative; or 2) shall replace the equipment or refund the purchase price for the equipment.

**THE BUYER'S REMEDY AGAINST BUNN FOR THE BREACH OF ANY OBLIGATION ARISING OUT OF THE SALE OF THIS EQUIPMENT, WHETHER DERIVED FROM WARRANTY OR OTHERWISE, SHALL BE LIMITED, AT BUNN'S SOLE OPTION AS SPECIFIED HEREIN, TO REPAIR, REPLACEMENT OR REFUND.**

In no event shall BUNN be liable for any other damage or loss, including, but not limited to, lost profits, lost sales, loss of use of equipment, claims of Buyer's customers, cost of capital, cost of down time, cost of substitute equipment, facilities or services, or any other special, incidental or consequential damages.

## TABLE OF CONTENTS

Auger Drive and Cooling Drum.....	14
Compressor and Mounting.....	20, 22
Condenser and Fan Mounting.....	18
Electrical and Operating Controls .....	32
Frame, Panels and Drip Tray.....	4
Hopper, Cover and Faucet.....	8
Liquid Autofill Kit (Optional) .....	32
Numerical Index .....	34
PAF Platform Assembly.....	10
Solenoid and Coolant Piping .....	24, 26, 28

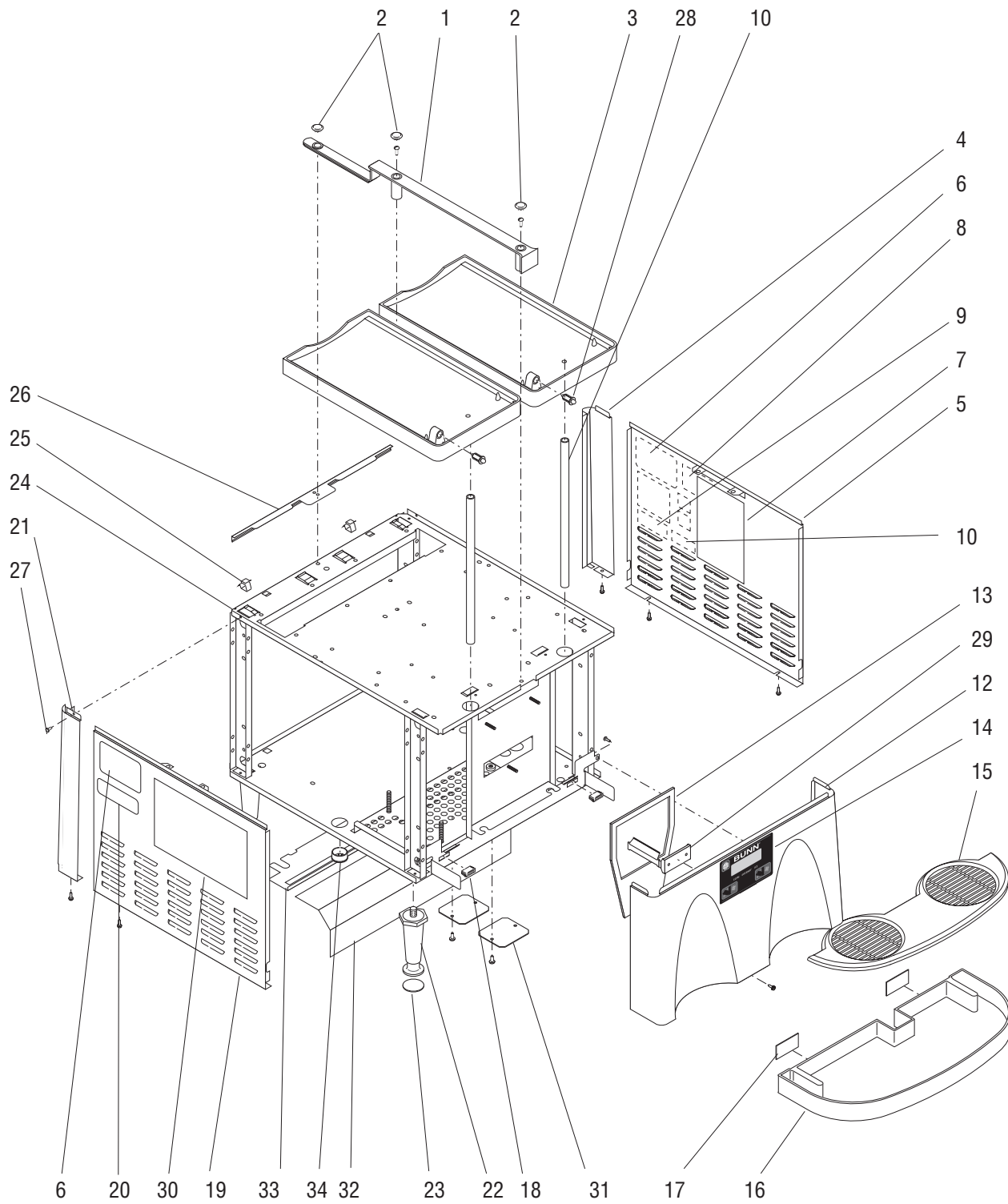

## FRAME, PANELS AND DRIP TRAYS

ITEM	PART NO.	QTY.	DESCRIPTION
1	27136.0002	1	Trim, Hopper/Drip Tray - WHI
	27136.0003	1	Trim, Hopper/Drip Tray - BLK
	02329.0000	2	Screw, Round Head - Locking #8-32 x .312"
2	27394.0000	3	Plug, Plastic - WHI
	27394.0001	3	Plug, Nylon - BLK
3	32111.0000	1	Drip Tray, Left Hopper - WHI
	32111.0001	1	Drip Tray, Left Hopper - BLK
	32111.0002	1	Drip Tray, Right Hopper - WHI
	32111.0003	1	Drip Tray, Right Hopper - BLK
	01311.0001	8	Screw, Truss Head - Locking #8-32 x .25"
4	27058.0000	1	Corner, Right Rear - SST
	27058.0002	1	Corner, Right Rear - BLK
	32580.0000	1	Screw, Hex Head #6-32 x .25"
5	32101.1000	1	Panel W/Decals, Right Side - SST (Includes items 6,7,8,9 & 10) (ULTRA-2)
	36182.1000	1	Panel W/Decals, Right Side - SST (Includes items 6,8,9 & 10) (ULTRA-2A)
	32101.1002	1	Panel W/Decals, Right Side - BLK (Includes items 6,7,8,9 & 10) (ULTRA-2)
	36182.1002	1	Panel W/Decals, Right Side - BLK (Includes items 6,8,9 & 10) (ULTRA-2A)
	32580.0000	2	Screw, Hex Head #6-32 x .25"
6	27442.0000	2	Decal, Warning - Moving Parts
7	32082.0000	1	Schematic, Electrical 120V (ULTRA-2)
	32082.0001*	1	Schematic, Electrical 230V (ULTRA-2A)
	32082.0002	1	Schematic, Electrical 120V (ULTRA-2 - Autofill Ready)
	32082.0003	1	Schematic, Electrical 230V (ULTRA-2A - Autofill Ready)
8	00986.0002	1	Decal, Warning - Electrical
9	29947.0000	1	Decal, Caution - Two Power Cords
10	29979.0000	1	Decal, Room Temperature
11	-----	2	Tube, Drain .375" I.D. x .50" O.D. x 10.88" (Order item 36)
12	32116.1000	1	Panel, Front - SST (Includes items 13,14 & 29)
	32116.1001	1	Panel, Front - BLK (Includes items 13,14 & 29)
	32580.0000	1	Screw, Hex Head #6 x .25"
	01317.0003	2	Screw, Truss Head - Locking #8-32 x .375"
13	29967.0000	1	Gasket, Electronic Box
14	32126.0001	1	Membrane Switch - BLK
15	32068.0000	1	Cover, Lower Drip Tray - WHI
	32068.0001	1	Cover, Lower Drip Tray - BLK
16	28086.0000	1	Drip Tray, Lower - WHI (Includes item 17)
	28086.0001	1	Drip Tray, Lower - BLK (Includes item 17)
17	21437.1000	2	Strike Assy, Self Adhesive
18	21436.0000	2	Catch, Magnetic

(Continued)

(Continued)

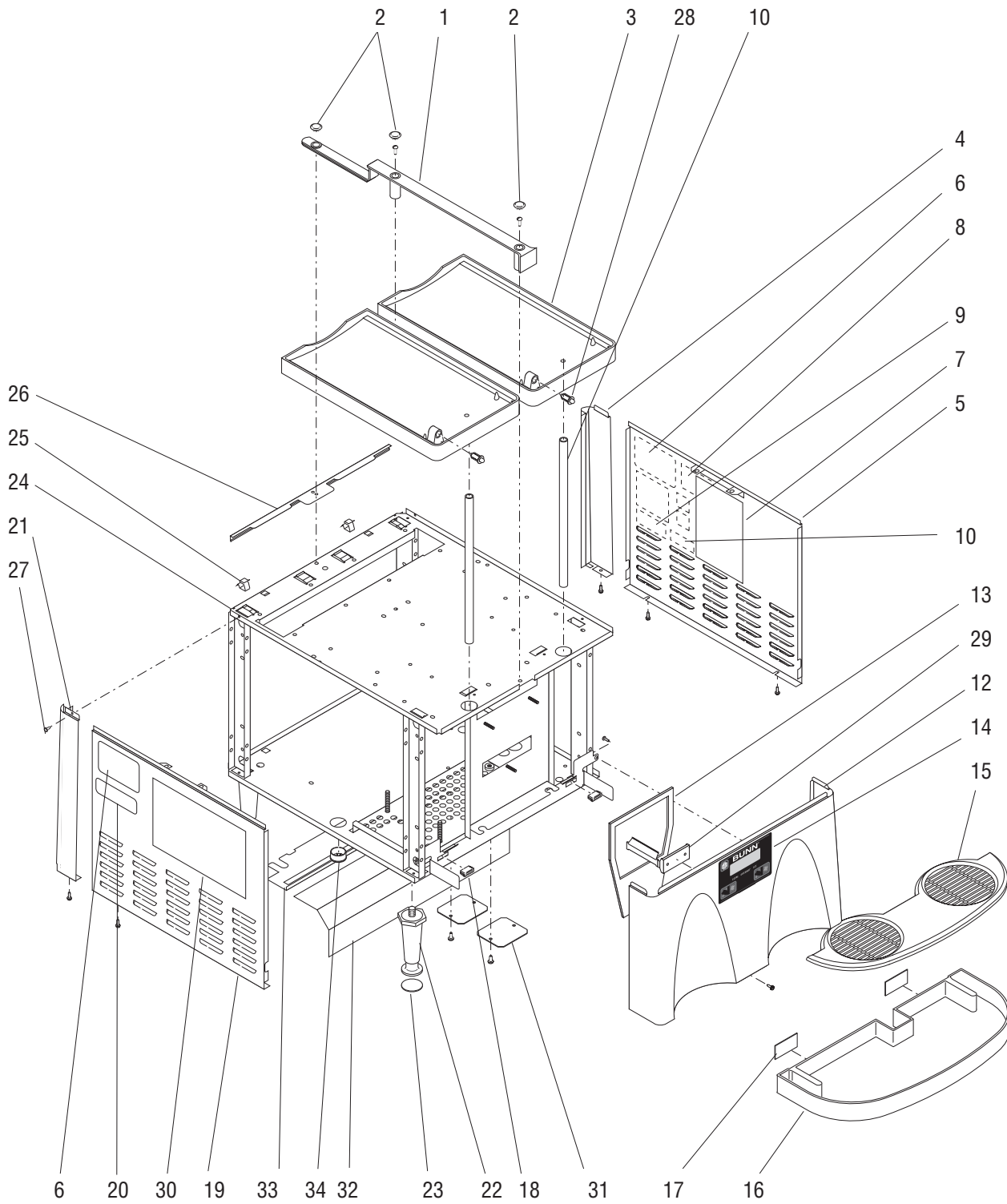

## FRAME, PANELS AND DRIP TRAYS

ITEM	PART NO.	QTY.	DESCRIPTION
19	32101.1004	1	Panel W/Decals, Left Side - SST (Includes items 6,20 & 30) (ULTRA-2)
	36182.1001	1	Panel W/Decals, Left Side - SST (Includes items 6,20 & 30) (ULTRA-2A)
	32101.1006	1	Panel W/Decals, Left Side - BLK (Includes items 6,20 & 30) (ULTRA-2)
	36182.1003	1	Panel W/Decals, Left Side - BLK (Includes items 6,20 & 30) (ULTRA-2A)
	32580.0000	2	Screw, Hex Head #6-32 x .25"
20	32162.0000	1	Decal, Coolant Charge (ULTRA-2)
	29373.0000	1	Decal, Coolant Charge (ULTRA-2A)
21	27058.0001	1	Corner, Left Rear - SST
	27058.0003	1	Corner, Left Rear - BLK
	32580.0000	1	Screw, Hex Head #6 x .25"
22	26528.0000	4	Leg, Black Plastic - 4" Adj. (See item 35)
	03354.0000	4	Leg, Black Plastic - 2.5" Adj. (See item 35)
23	03996.0000	4	Pad, Rubber - 4" Adj. Legs (See item 35)
	03993.0000	4	Pad, Rubber - 2.5" Adj. Legs (See item 35)
24	32124.0000	1	Frame, Base (Models with AMERICOLD compressors)
	32793.0000	1	Frame, Base (Models with EMBRACO compressors)
	37906.0000	1	Frame, Base (Models with EMBRACO compressors - Autofill Ready)
25	00927.0000	4	Clip, Spring
26	27131.0000	1	Trim, Frame - Rear - SST
	27131.0001	1	Trim, Frame - Rear - BLK
27	28098.0000	2	Fastener, Snap-in
28	29702.1000	2	Plunger Assy, Hopper Lock
29	29976.0000	1	Mount, Cable
30	29959.0001	1	Decal, Cleaning Instructions 120V (ULTRA-2)
	29959.0002	1	Decal, Cleaning Instructions 230V (ULTRA-2A)
	29959.8002	1	Decal, Cleaning Instructions Spanish 120V (ULTRA-2)
31	37883.0000	2	Cover, Hole (Autofill Ready)
	01382.0000	4	Screw, Truss Head #6-32 x .38"
32	36187.0000	1	Vinyl Deflector 230V (ULTRA-2A)
33	36188.0000	1	Bracket 230V (ULTRA-2A)
34	20622.0005	1	Bushing
35	13255.0003	-	Leg Kit, 4" Adj. Legs (Includes 4 Legs and Pads)
	13255.0006	-	Leg Kit, 2.5" Adj. Legs (Includes 4 Legs and Pads)
36	12421.1001	-	Tube, Clear Vinyl (12" Long)
	12421.1002	-	Tube, Clear Vinyl (60" Long)
	12421.1003	-	Tube, Clear Vinyl (120" Long)

Not Illustrated

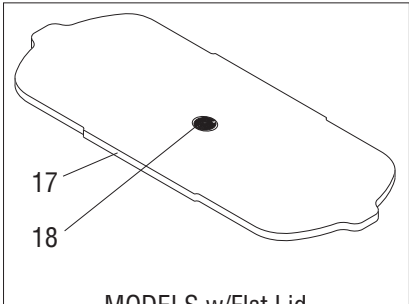
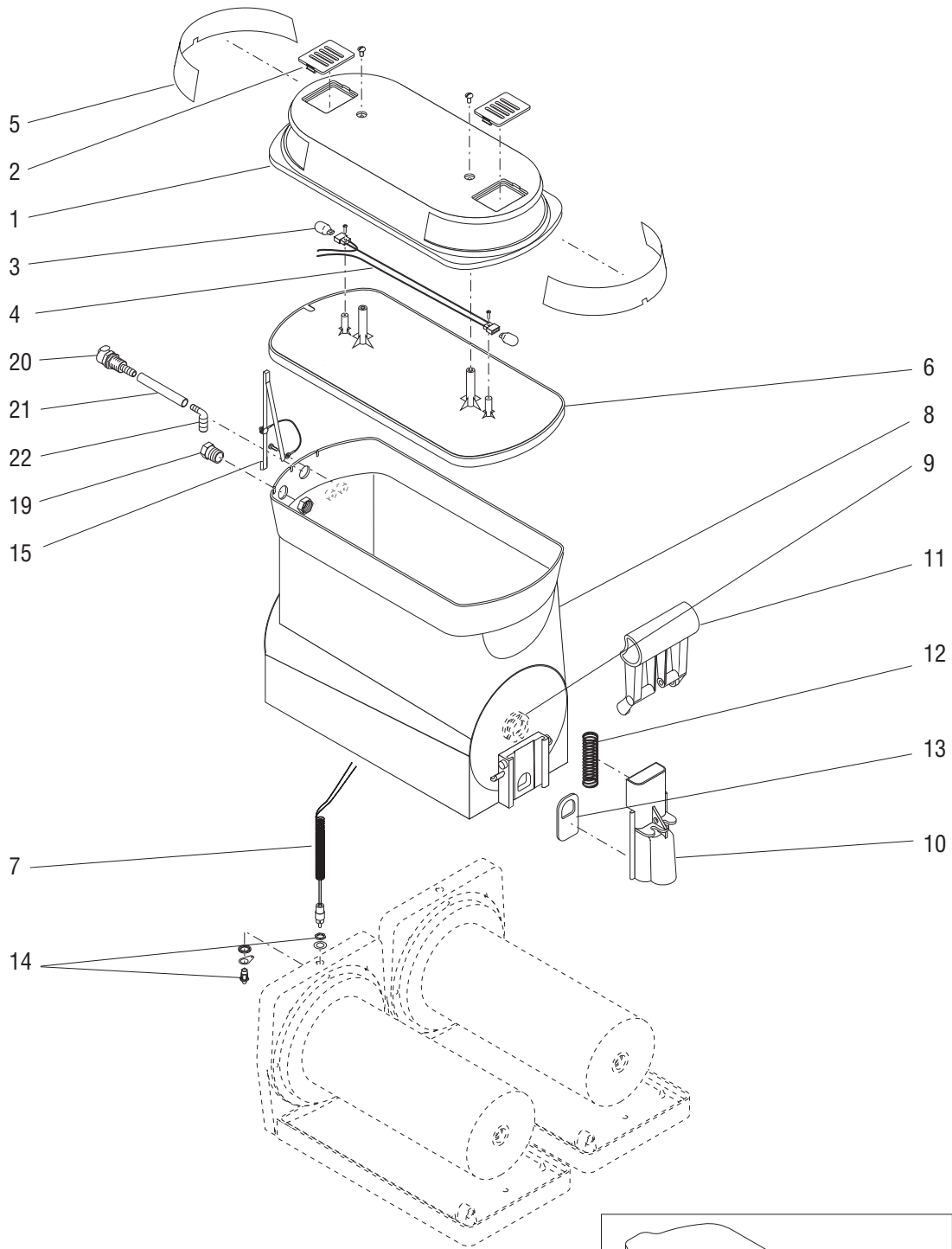



## HOPPER, COVER AND FAUCET

ITEM	PART NO.	QTY.	DESCRIPTION
-	32196.1000	2	Cover Assembly, Hopper - WHI (Includes items 1 thru 7)
	32196.1001	2	Cover Assembly, Hopper - BLK (Includes items 1 thru 7)
1	-----	2	Cover, Hopper - WHI
	-----	2	Cover, Hopper - BLK
	01315.0000	4	Screw, Truss Head #8-32 x .38"
2	32105.0000	4	Insert, Hopper Lid Vent - WHI
	32105.0001	4	Insert, Hopper Lid Vent - BLK
3	27446.0000	4	Lamp, T-5 Wedge Base
4	27445.1000	2	Lamp Holder/Socket Assy (Includes two of item 16)
	32096.0001	4	Screw, Pan Head #2-56 x .50"
5	32266.0000	4	Insert, Hopper Display
6	32195.0000	2	Liner Assy, Hopper Cover
7	32267.1000	2	Cord Assy, Lamp (Includes two of item 16)
8	32190.1000	2	Hopper Assy. (Includes item 9)
	32190.1001	2	Hopper Assy. (For Models with PAF) (Includes item 9)
	32190.1002	2	Hopper Assy. (For Models with AFPO) (Includes item 9)
	32190.1003	2	Hopper Assy. (For Models Autofill Ready) (Includes item 9)
9	32189.0000	2	Bushing, Auger Nose
10	32191.0000	2	Faucet - WHI
11	32265.0001	2	Handle, Faucet - BLK
12	32193.0000	2	Spring, Faucet
13	32268.0000	2	Seal
14	27643.0000	2	Connector Assy (Includes Nut, Washer, Leads & Plug)
	01532.0001	2	Lockwasher, Internal-tooth .375"
15	33176.0001	2	Tether/Probe Assy (For Models with PAF)
	39055.0001	2	Tether/Probe Assy (For Models Autofill Ready)
	01393.0000	2	Screw, Truss Head #6 x .25"
16	03851.0000	4	Wire Nut (Not Illustrated)
17	29481.0000	1	Cover, Flat (Includes item 18)
18	00778.0000	1	Decal, BUNN
19	28776.0000	4	Plug (Two less used on Liquid Autofill with No Water lines)
	24566.0000	4	Nut
20	28756.0000	4	Fitting, Quick Disconnect
21	28755.0003*	4	Tube, Norprene .25" ID x 1.25"
22	28770.0000	4	Elbow .25" Barb x .50" Barb

Not available. Order Cover Assembly above

Autofill Ready Models

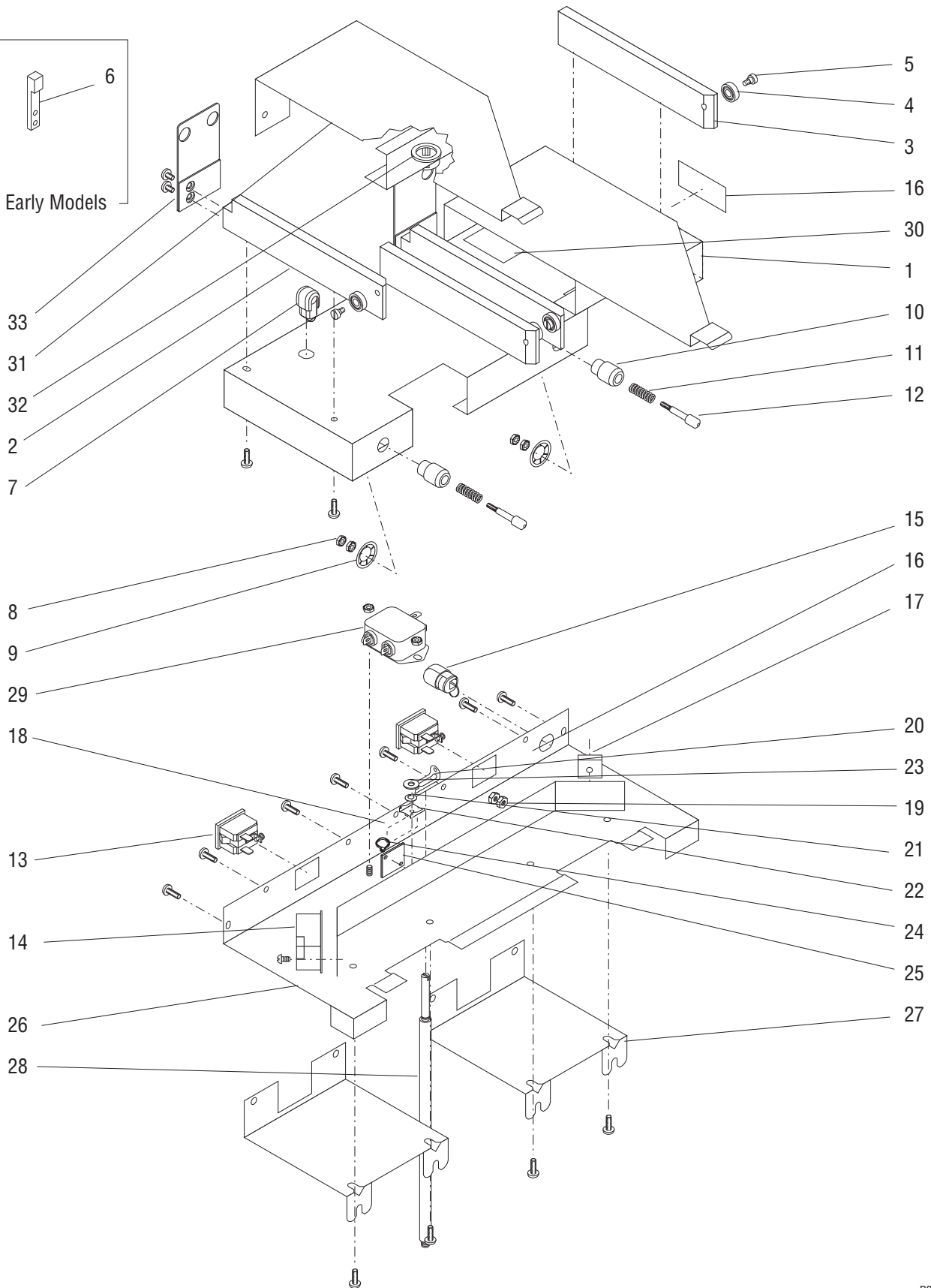
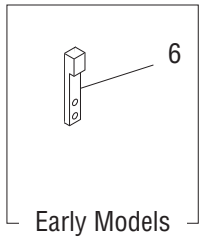

## PAF PLATFORM ASSEMBLY

ITEM	PART NO.	QTY.	DESCRIPTION
-	29941.1000	1	Platform Assy. 120V SST (Includes items 1 thru 28 and 30 thru 34)
-	29941.1001	1	Platform Assy. 120V BLK (Includes items 1 thru 28 and 30 thru 34)
-	29941.1002	1	Platform Assy. 230V SST (Includes items 1 thru 34)
-	29941.1003	1	Platform Assy. 230V BLK (Includes items 1 thru 34)
1	29940.0000	1	Housing SST
	29940.0002	1	Housing BLK
2	29591.0001	2	Guide Rail RH
	01330.0000	4	Screw #10-32 x .38"
3	29591.0002	2	Guide Rail LH
	01330.0000	4	Screw #10-32 x .38"
4	29724.0000	4	Roller
5	24457.0001	4	Shoulder Bolt
	01522.0001	4	Washer
6	32632.0000	2	Latch (Early Models)
	01311.0001	4	Screw, Truss Head Locking #8-32 x .25"
7	01666.0002	1	Bushing, Relief (120V)
	05746.0000	1	Bushing, Relief (230V)
8	00906.0000	4	Nut
9	29742.0000	2	Retainer
10	29726.0000	2	Housing, Spring Contact
11	27788.0000	2	Spring
12	27748.0000	2	Pin
13	03628.0000	2	Receptacle 120V
	32197.0000	2	Receptacle 230V
14	32104.0000	1	Relay, Lighting
	01382.0000	2	Screw, Truss Head #6-32 x .38"
15	00707.0000	1	Bushing, Relief
16	29947.0000	1	Decal, Dual Power Cord
17	22126.0000	1	Rectifier
	01370.0000	1	Screw, Pan Head #8-32 x .75"
18	29844.0000	1	Decal, Receptacle - PAF Only
	29844.0001	1	Decal, Receptacle - PAFA Only
19	00908.0000	2	Nut, Grounding Stud
20	33524.0000	1	Latch, Support Rod
21	33527.0000	1	Washer
22	33525.0000	1	Guide
23	01521.0000	1	Washer

(Continued)

(Continued)

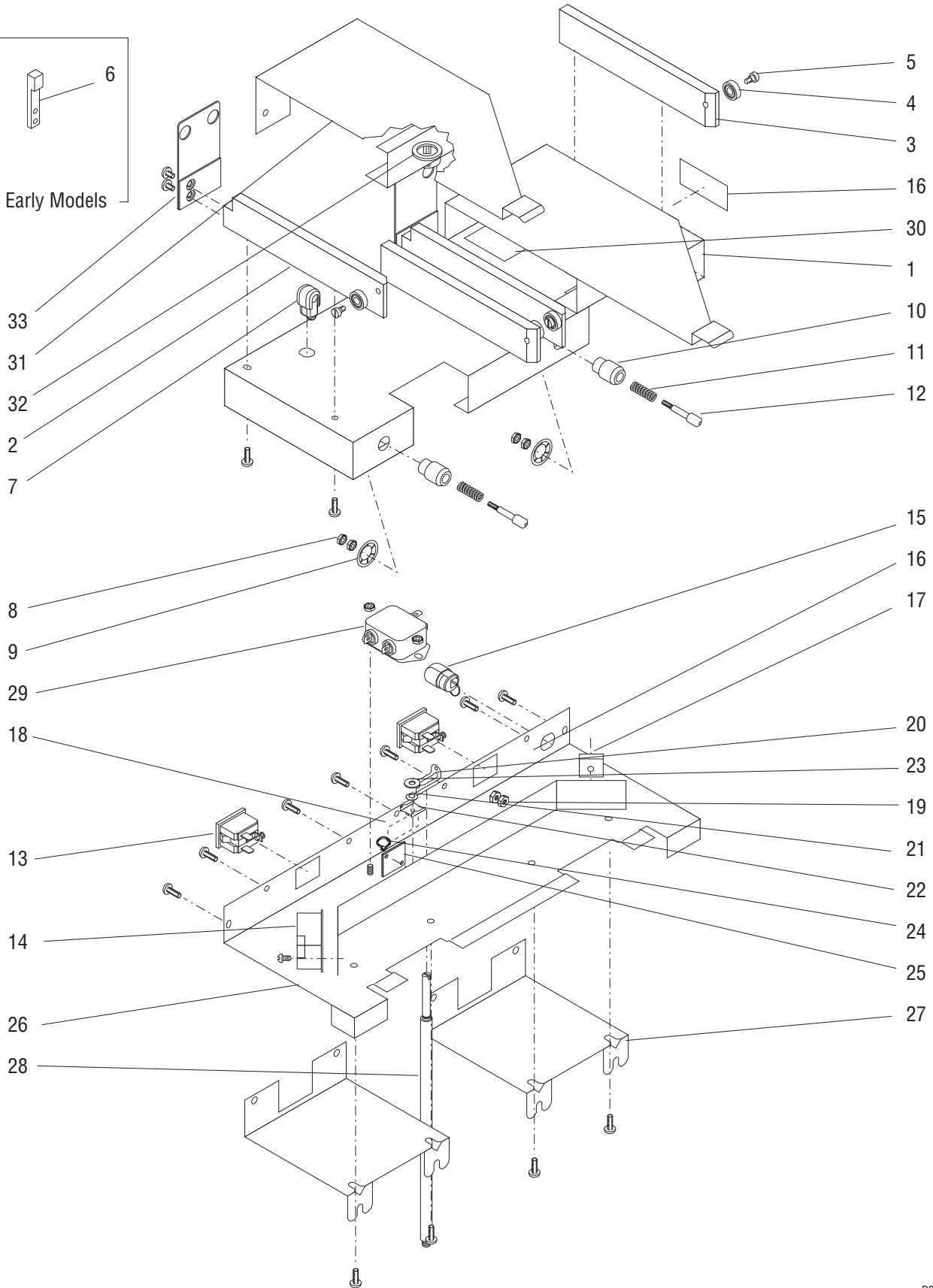
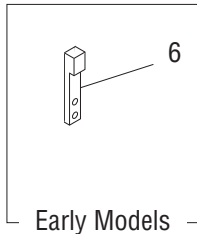

## PAF PLATFORM ASSEMBLY

ITEM	PART NO.	QTY.	DESCRIPTION	
24	00617.0000	1	Cable Tie	
25	22749.0000	1	Mounting Pad, Cable Tie	
26	29943.0000	1	Cover, Bottom SST (120V)	
	29943.0001	1	Cover, Bottom BLK (120V)	
	29943.0002	1	Cover, Bottom SST (230V)	
	29943.0003	1	Cover, Bottom BLK (230V)	
	01315.0000	7	Screw, SST, Truss Head #8-32 x .38"	
	02322.0002	7	Screw, BLK, Truss Head #8-32 x .38"	
27	29942.0000	2	Bracket SST	
	29942.0001	2	Bracket BLK	
	01317.0000	4	Screw, Truss Head #8-32 x .50"	
28	29936.0000	1	Rod, Support	
29	29446.0001	1	EMI Filter (230V)	
	00908.0000	2	Nut #8-32	
30	00986.0002	1	Decal, Electrical Warning	
31	34573.0000	2	Latch Bracket	
32	01663.0000	2	Bushing, Snap	
33	34575.0000	2	Plate, Guide	
	01311.0001	4	Screw, Truss Head Locking #8-32 x .25"	} Late Models
34	20630.0007	1	Power Cord (120V)	
	28111.0005	1	Power Cord (230V)	
	32212.0001	1	Power Cord (230V EURO)	
35	29948.0000	1	Harness, Main (120V)	
	29948.0001	1	Harness, Main (230V)	
36	32267.1000	1	Lamp Cord (Includes item 34)	} Not Illustrated
37	29763.0000	2	Resister, Probe Detector	
38	03851.0000	2	Wire Nut	

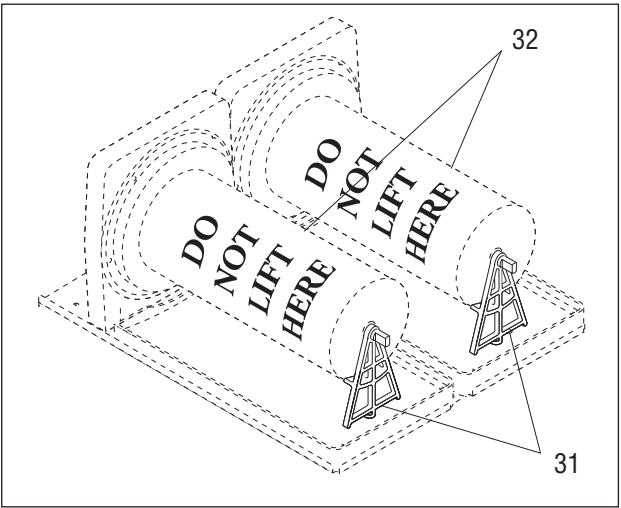
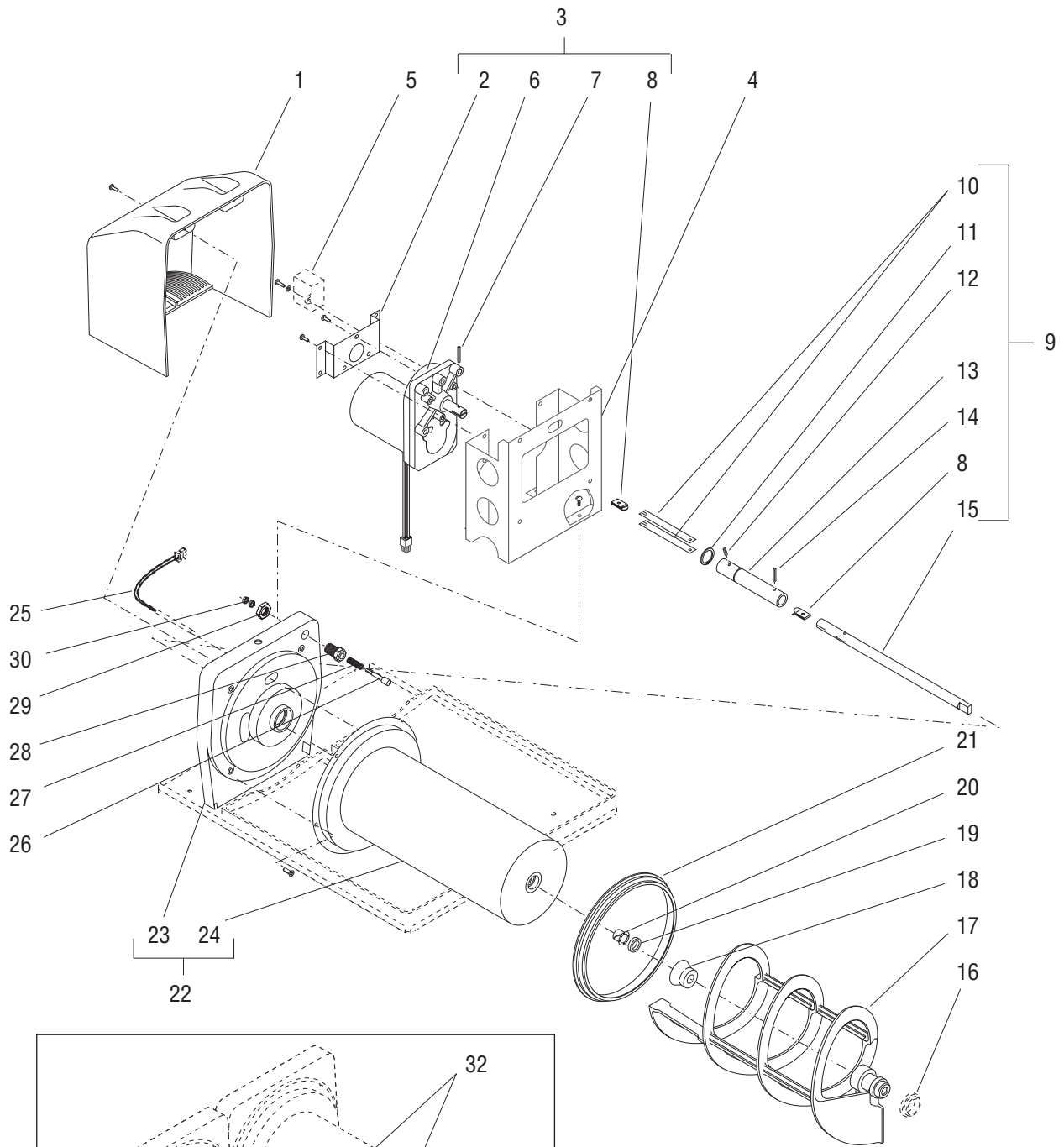

## AUGER DRIVE AND COOLING DRUM

ITEM	PART NO.	QTY.	DESCRIPTION
1	27231.0000	2	Cover, Auger Motor - WHI
	27231.0001	2	Cover, Auger Motor - BLK
	01317.0003	4	Screw, Truss Head - Locking #8-32 x .375"
2	27232.0000	2	Bracket, Auger Motor Mounting
	01317.0003	6	Screw, Truss Head - Locking #8-32 x .375"
3	28093.1000	2	Motor Assy, Auger (Includes items 2, 6, 7 & 8) (120V)
	28093.1001	2	Motor Assy, Auger (Includes items 2, 6, 7 & 8) (230V)
	01326.0002	6	Screw, Pan Head #10-32 x .375"
4	32108.0000	2	Bracket, Auger Motor/Cooling Drum Mounting
	01311.0001	8	Screw, Truss Head - Locking #8-32 x .25"
5	-----	2	Capacitor, Motor (See ELECTRICAL AND OPERATING CONTROLS)
	01317.0001	2	Screw, Truss Head - Locking #8-32 x .50"
	01501.0000	2	Washer #8
	01511.0000	2	Lockwasher, Ext.-tooth #8
6	27179.1000	1	Motor Assembly, Auger (Includes Leads and Terminals) (120V)
	27179.1001	1	Motor Assembly, Auger (Includes Leads and Terminals) (230V)
7	34836.0000	1	Pin, Headed .125" O.D. x .94"
8	27440.0001	2	Bearing, Torsion Spring
9	28081.0001	2	Shaft Assy, Auger Drive (Includes items 8, 10 thru 15) (Also use item 33)
10	27223.0000	2	Spring, Torsion
11	27228.0000	1	Snap Ring
12	11556.0001	1	Pin, Split .125" O.D. x .437"
13	27224.0000	1	Retainer, Torsion Spring
14	34836.0001	1	Pin, Split .125" O.D. x .75"
15	32449.0000	1	Shaft, Auger
16	-----	2	Bushing, Auger - Front (See HOPPER, COVER AND FAUCET)
17	32106.1000	2	Auger
18	26780.0000	2	Seal, Auger Shaft
19	37593.0000	2	Seal, Cooling Drum
20	26781.0000	2	Bushing, Auger Shaft
21	32079.0000	2	Seal, Cooling Drum/Hopper
22	32092.0000	2	Drum Assembly, Cooling - WHI (Includes items 23 & 24)
	32092.0001	2	Drum Assembly, Cooling - BLK (Includes items 23 & 24)
	32092.0002	2	Drum Assembly, Cooling - WHI (Includes items 23 & 24)(Autofill Ready)
	32092.0003	2	Drum Assembly, Cooling - BLK (Includes items 23 & 24)(Autofill Ready)
	01377.0000	8	Screw, Flat Head #8-32 x .75"

(Continued)

(Continued)

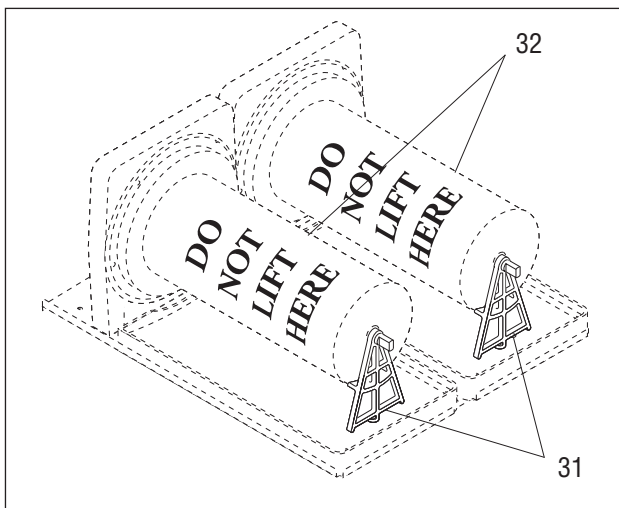
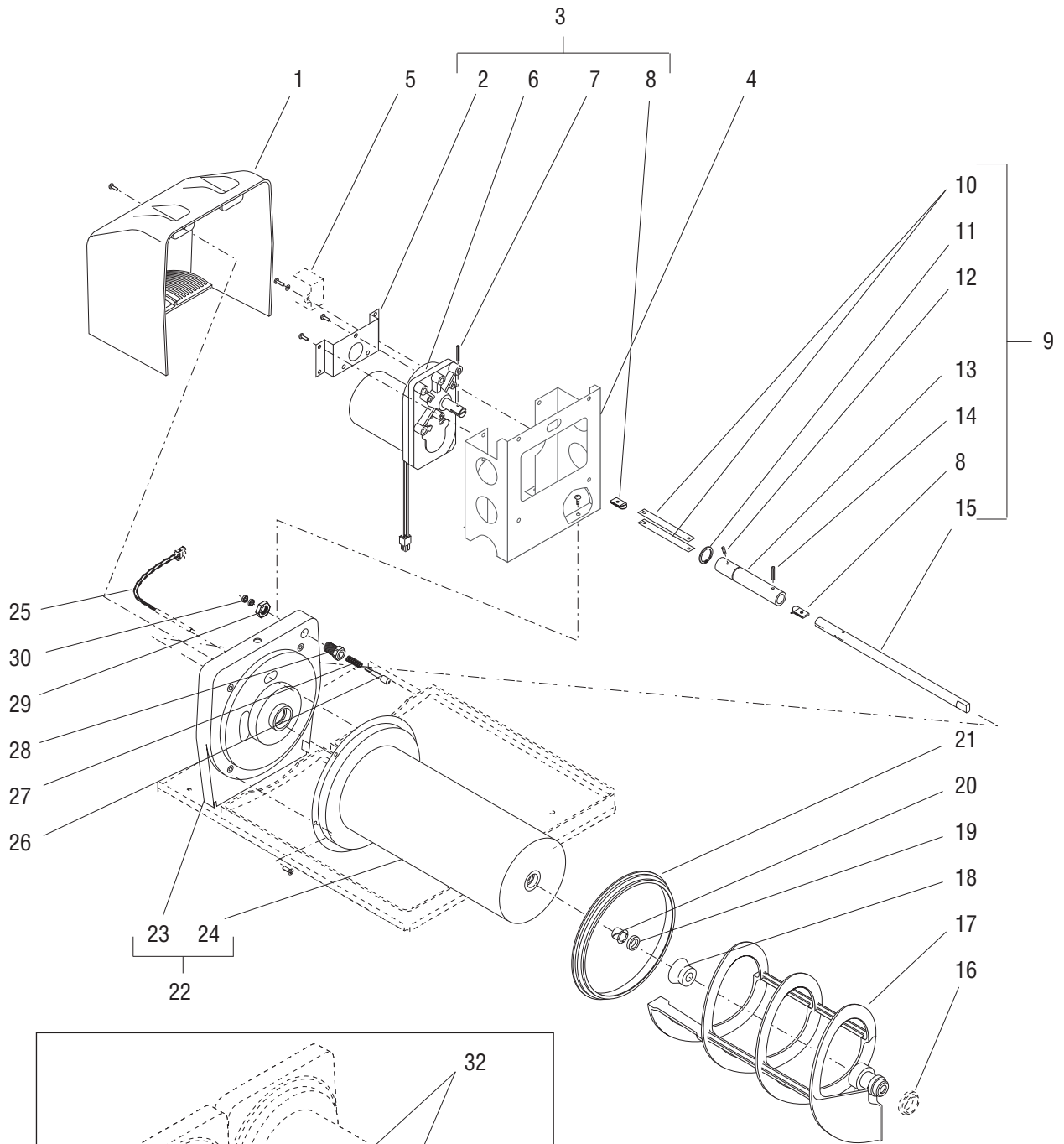



## AUGER DRIVE AND COOLING DRUM

ITEM	PART NO.	QTY.	DESCRIPTION
23	32091.0000	1	Mount Assembly, Cooling Drum - WHI
	32091.0001	1	Mount Assembly, Cooling Drum - BLK
	32091.0002	1	Mount Assembly, Cooling Drum - WHI(Autofill Ready)
	32091.0003	1	Mount Assembly, Cooling Drum - BLK(Autofill Ready)
24	-----	1	Drum, Cooling (Not Available. Order item 22)
25	-----	-	Temperature Sensor Assy (See ELECTRICAL AND OPERATING CONTROLS)
26	27748.0000	2	Pin, Spring Contact
27	27788.0000	2	Spring
28	37955.0000	2	Housing, Spring Contact
29	00942.0000	2	Nut, Hex, Brass .50"-20
30	00906.0000	4	Nut, Hex #6-32
31	28027.0000	2	Support, Cooling Drum (For Shipping and Cooling Drum Adjustment)
32	28236.0000	2	Label, DO NOT LIFT HERE (For Shipping Only)
33	M2548.1000	-	Lubricant, Krytox .50 oz (Not illustrated)

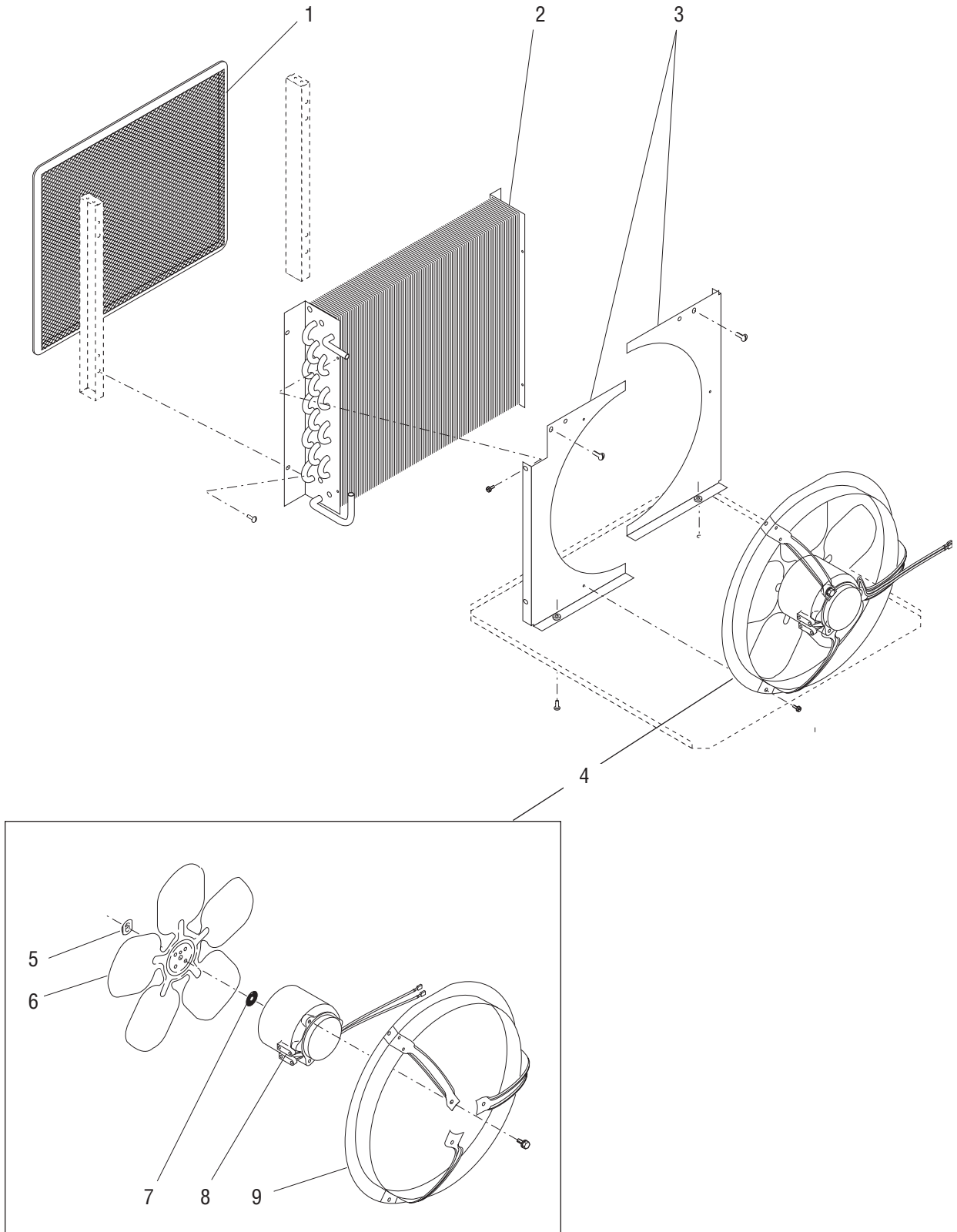

## CONDENSER AND FAN MOUNTING

ITEM	PART NO.	QTY.	DESCRIPTION
1	28122.0000	1	Filter, Air
2	26791.0000	1	Condenser Assy
	02308.0000	4	Screw, Pan Head Serrated #8-32 x .375"
3	32084.0000	1	Shroud, Condenser - Right Half
	32084.0002	1	Shroud, Condenser - Right Half (Autofill Ready)
	32084.0001	1	Shroud, Condenser - Left Half
	02332.0001	4	Screw, Hex Head Crimptite #6 x .25"
	01317.0003	4	Screw, Truss Head - Locking #8-32 x .375"
4	27180.0000	1	Fan Assy, Condenser - 120V (Includes items 5 thru 9)
	29084.0001	1	Fan Assy, Condenser - 230V (Includes items 5 thru 9)
	29084.0000	1	Fan Assy, Condenser - 115V (Includes items 5 thru 9)
	02332.0002	3	Screw, Hex Head - Thread Cutting #6 x .375"
5	27257.0000	1	Speed Nut .25"-20
6	27220.0000	1	Blade, Condenser Fan 120V
	29159.0000	1	Blade, Condenser Fan 115V or 230V
7	27258.0000	1	Silencer, Fan
8	27221.0000	1	Motor, Condenser Fan - 120V (Includes Leads and Terminals)
	29160.0001	1	Motor, Condenser Fan - 230V (Includes Leads and Terminals)
	29160.0000	1	Motor, Condenser Fan - 115V (Includes Leads and Terminals)
9	27219.0000	1	Shroud/Mount, Condenser Fan
	27243.0000	3	Screw, Hex Head Thread Forming #8-32 x .437"

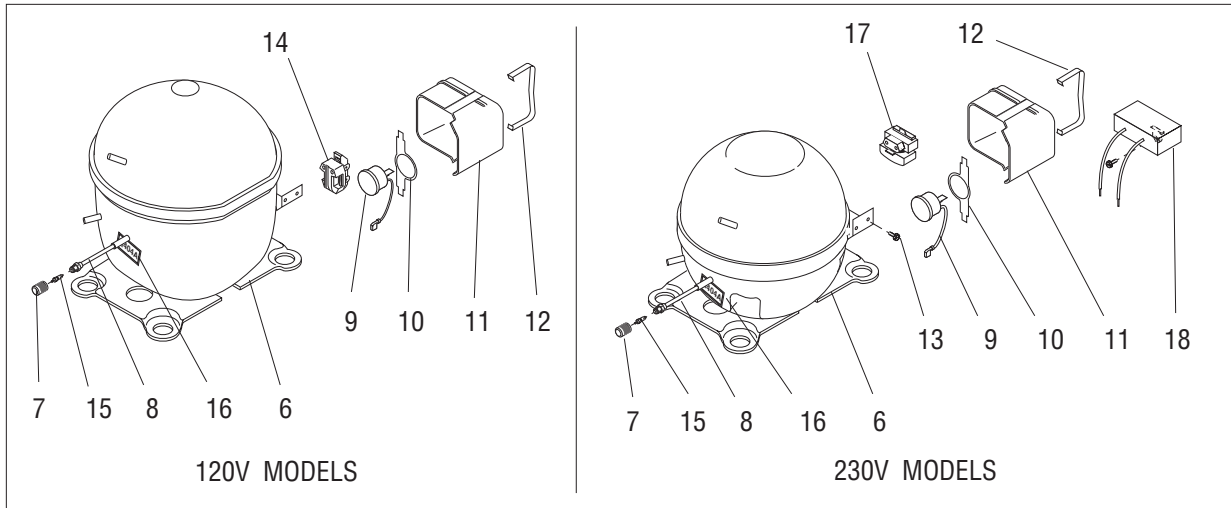
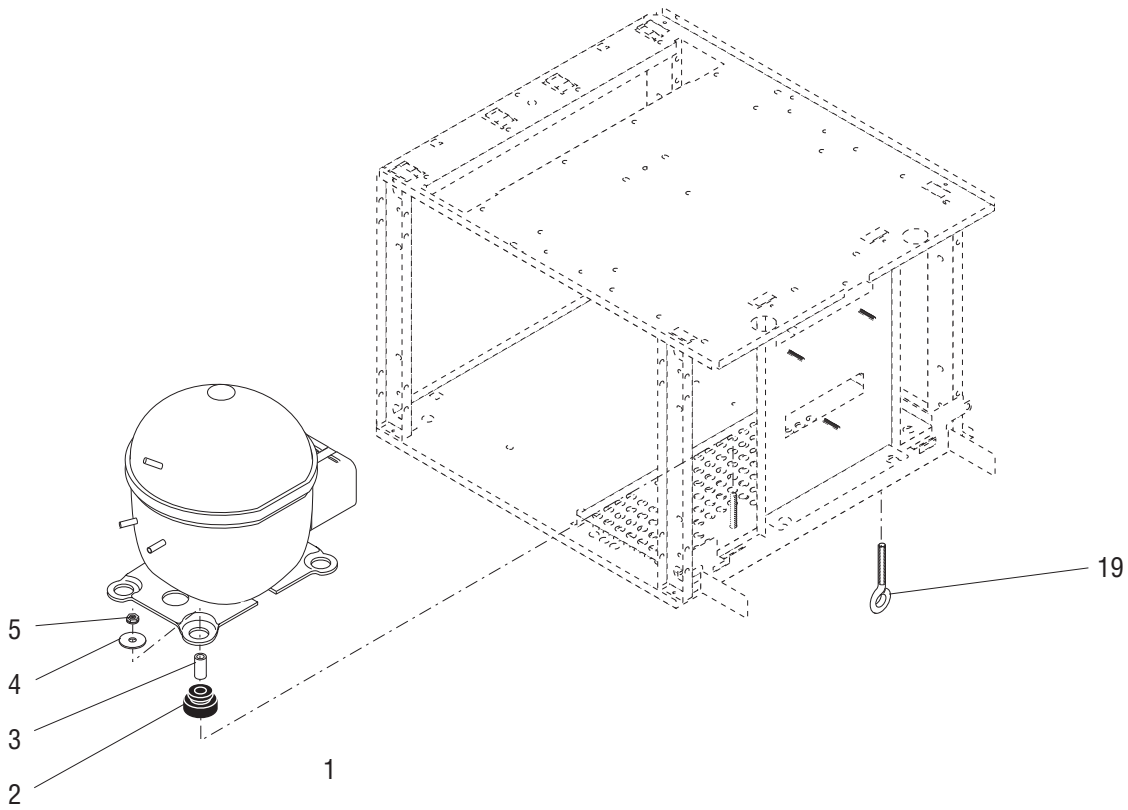

## COMPRESSOR AND MOUNTING (AMERICOLD)

ITEM	PART NO.	QTY.	DESCRIPTION
1	32073.1000	1	Compressor Assy 120V (Includes items 2, 3, 6, 9 thru 12 and 14)
	29932.1000	1	Compressor Assy 230V (Includes items 2, 3, 6, 9, 11, 12, 13, 17 and 18)
2	-----	4	Grommet, Compressor Mounting
3	-----	4	Sleeve, Compressor Mounting
			} Order item 20
4	34529.0000	4	Washer, .281" I.D. x 1.0" O.D.
5	23700.0000	4	Nut, Hex Keps .25"-20
6	-----	1	Compressor (Not Available. Order item 1)
7	27641.0000	1	Cap, Access Valve (Procure Locally)
8	27551.0000	1	Valve Assy, Access (Includes items 7 & 15) (Requires brazing to Install)
9	27407.0000	1	Overload Protector (120V)
	27407.0001	1	Overload Protector (230V)
10	27403.0000	1	Retainer, Overload Protector (120V)
11	27408.0000	1	Cover, Compressor Terminal
12	32095.0000	1	Retainer, Compressor Terminal Cover (120V)
	27404.0000	1	Retainer, Compressor Terminal Cover (230V)
13	02335.0001	1	Screw, Hex Head Crimptite #8 x .375"
14	32094.0000	1	Relay, Compressor Start (120V)
15	27642.0000	1	Valve Core, .25"
16	28651.0000	1	Label - R404A
17	27406.0002	1	Starter, Motor (230V)
18	27405.0001	1	Capacitor, Run (230V)
	02332.0002		Screw, Hex Crimptite #6 x .375"
19	-----	1	Eyebolt (Shipping Only)
	-----	1	Tag, Eyebolt Shipping Notice (Not illustrated)
20	27613.0000	1	Kit, Compressor Mounting (Includes 4 each of item 2 & 3)

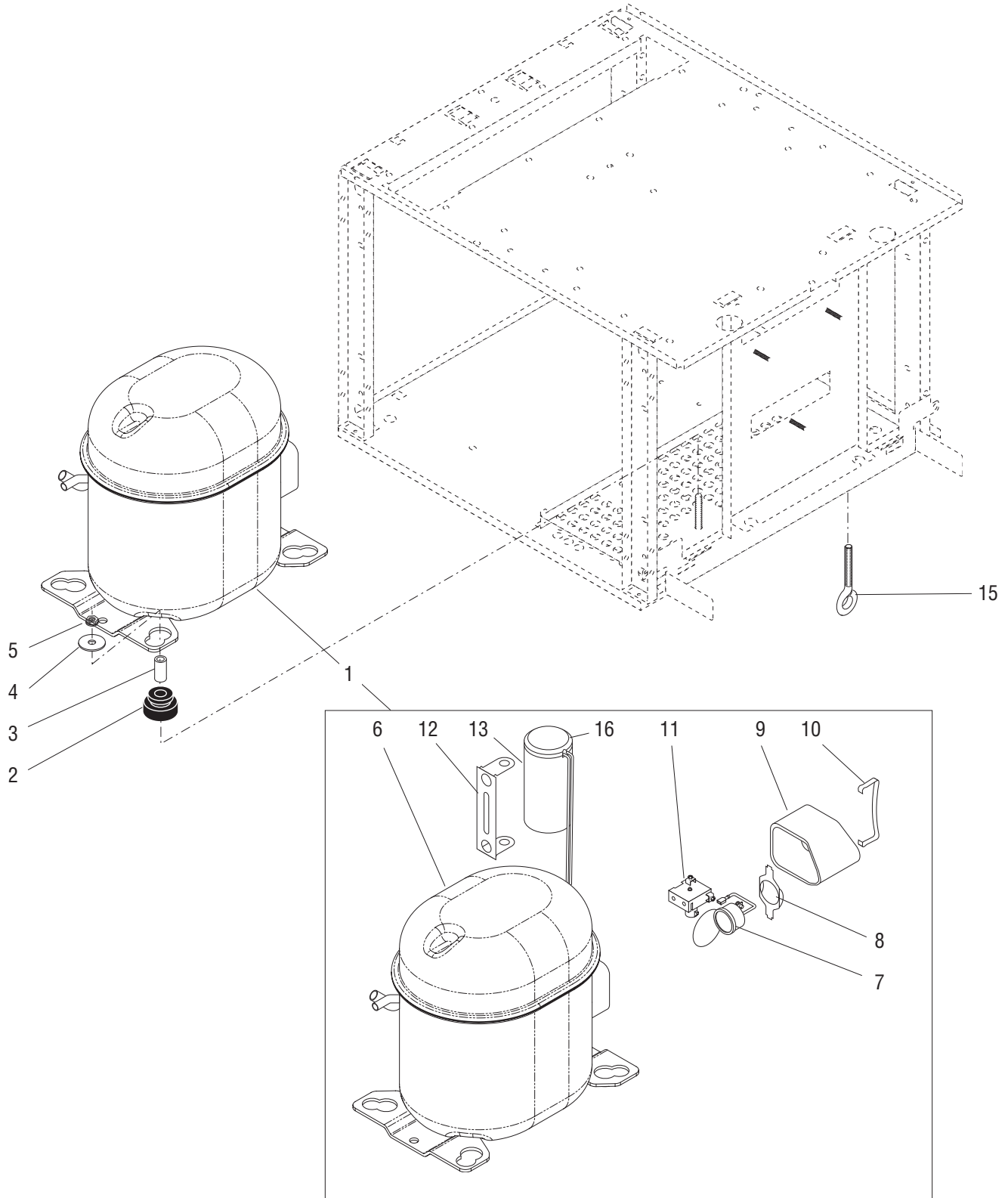

## COMPRESSOR AND MOUNTING (EMBRACO)

ITEM	PART NO.	QTY.	DESCRIPTION
1	34296.1000	1	Compressor Assy (Model T2155) 120V (Includes items 2, 3, 6 thru 14)
	-----	1	Compressor Assy (Model T2155) 230V (Order 35980.0001)
	35980.1000	1	Compressor Assy (Model T2168) 230V (Includes items 2, 3, 6 thru 14)
2	32797.0000	4	Grommet, Compressor Mounting
3	32798.0000	4	Sleeve, Compressor Mounting
4	34529.0000	4	Washer, .281" I.D. x 1.0" O.D.
5	23700.0000	4	Nut, Hex Keps .25"-20
6	-----	1	Compressor (Not Available. Order item 1)
7	34254.0002	1	Overload Protector (120V)
	39136.0000	1	Overload Protector (230V)
8	34253.0000	1	Retainer, Overload Protector
9	34252.0001	1	Cover, Compressor Terminal
10	34251.0000	1	Retainer, Compressor Terminal Cover
11	34255.0002	1	Relay, Compressor Start (120V)
	39137.0000	1	Relay, Compressor Start (230V)
12	32799.0002	1	Bracket, Capacitor
13	32795.0002	1	Capacitor, Run (120V)
	39152.0000	1	Capacitor, Run (230V)
14	28651.0000	1	Label - R404A (Not illustrated)
15	-----	1	Eyebolt (Shipping Only)
	-----	1	Tag, Eyebolt Shipping Notice (Not illustrated)
16	39134.0000	1	Cover
17	39142.0000	1	Screw M4 x 7mm (Not Illustrated)





## SOLENOID AND COOLANT PIPING (AMERICOLD)

ITEM	PART NO.	QTY.	DESCRIPTION
1	-----	1	Condenser (See Condenser and Fan Mounting)
2	32088.0001	1	Tube .375" O.D. Accumulator to Left Cooling Drum (Requires brazing to install)
3	27607.1000	1	Tube .093" O.D. Solenoid to Left Cooling Drum (Requires brazing to install)
	27607.1001	1	Tube .093" O.D. Solenoid to Right Cooling Drum (Requires brazing to install)
4	32087.0001	1	Tube .375" O.D. Accumulator to Right Cooling Drum (Requires brazing to install)
5	28925.0000	2	Adapter, Reducing (Requires brazing to install)(Early Models)
6	-----	2	Cooling Drum (See Auger Drive and Cooling Drum)
7	32113.0000	1	Bracket, Solenoid Mounting
	01317.0003	1	Screw, Truss Head, Locking #8-32 x .38"
8	32133.0000	2	Solenoid Assy (120V)
	32133.0001	2	Solenoid Assy (230V)
	02332.0001	2	Screw, Crimpite #6 x .25"
9	-----	1	Compressor (See Compressor and Mounting)
10	32256.0000	1	Dryer Assembly (Requires brazing to install)
11	32086.0001	1	Tube .312" O.D. Accumulator to Compressor (Requires brazing to install)
12	32085.0001	1	Tube .250" O.D. Condenser to Compressor (Requires brazing to install)
13	-----	1	Tube, Condenser to Dryer (Early Models) (Requires brazing to install)
	34211.0000	1	Tube, Condenser to Dryer (Late Models) (Includes items 15 & 16) (Requires brazing to install)
14	32257.0000	1	Accumulator, Suction (Requires brazing to install)
15	27641.0000	1	Cap, Valve Access
16	27642.0000	1	Valve Core
17	27411.0000	1	Cup, Condensate
18	M2316.1000	-	Insulation, Tube .375" I.D. x 6 ft LG (As Required)
19	00617.0000	8	Tie, BLK Nylon 3.90" LG (As Required)
20	03290.0000	7	Tie, WHI Nylon 5.6" LG

} Not Illustrated

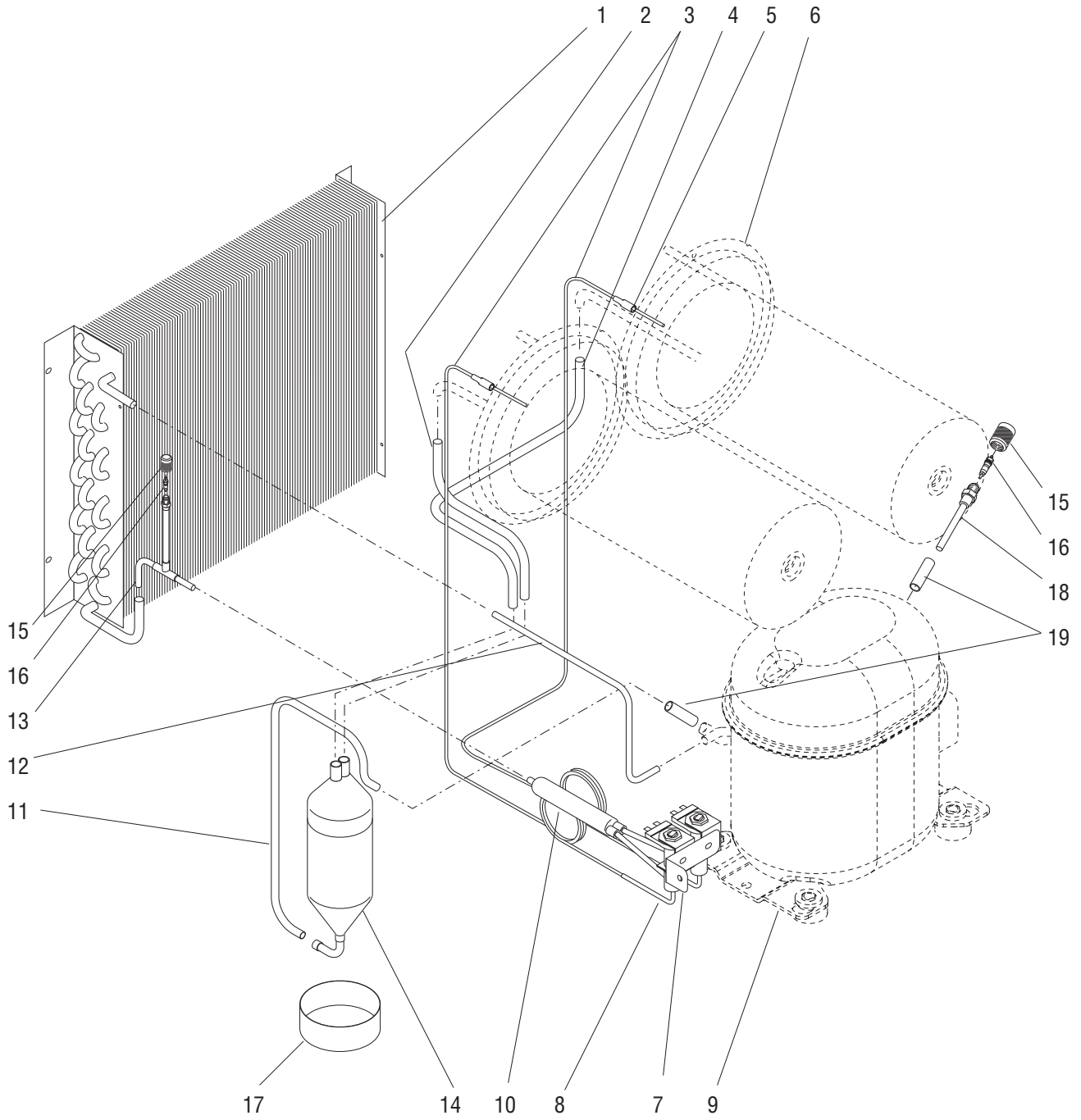

## SOLENOID AND COOLANT PIPING (EMBRACO-120V)

ITEM	PART NO.	QTY.	DESCRIPTION
1	-----	1	Condenser (See Condenser and Fan Mounting)
2	32088.0001	1	Tube .375" O.D. Accumulator to Left Cooling Drum (Requires brazing to install)
3	27607.1000	1	Tube .093" O.D. Solenoid to Left Cooling Drum (Requires brazing to install)
	27607.1001	1	Tube .093" O.D. Solenoid to Right Cooling Drum (Requires brazing to install)
4	32087.0001	1	Tube .375" O.D. Accumulator to Right Cooling Drum (Requires brazing to install)
5	28925.0000	2	Adapter, Reducing (Requires brazing to install)(Early Models)
6	-----	2	Cooling Drum (See Auger Drive and Cooling Drum)
7	32113.0000	1	Bracket, Solenoid Mounting
	01317.0003	1	Screw, Truss Head, Locking #8-32 x .38"
8	32133.0000	2	Solenoid Assy (120V)
	32133.0001	2	Solenoid Assy (230V)
	02332.0001	2	Screw, Crimpite #6 x .25"
9	-----	1	Compressor (See Compressor and Mounting)
10	32256.0000	1	Dryer Assembly (Requires brazing to install)
11	34257.0001	1	Tube .312" O.D. Accumulator to Compressor (Requires brazing to install)
12	34258.0001	1	Tube .250" O.D. Condenser to Compressor (Requires brazing to install)
13	34211.0000	1	Tube, Condenser to Dryer (Includes items 15 & 16) (Requires brazing to install)
14	32257.0000	1	Accumulator, Suction (Requires brazing to install)
15	27641.0000	2	Cap, Valve Access
16	27642.0000	2	Valve Core
17	27411.0000	1	Cup, Condensate
18	28645.0000	1	Valve, Access (Includes items 15 & 16) (Requires brazing to install)
19	34256.0001	2	Tube, Spacer (Requires brazing to install)
20	M2316.1000	-	Insulation, Tube .375" I.D. x 6 ft LG (As Required)
21	00617.0000	8	Tie, BLK Nylon 3.90" LG (As Required)
22	03290.0000	7	Tie, WHI Nylon 5.6" LG

} Not Illustrated

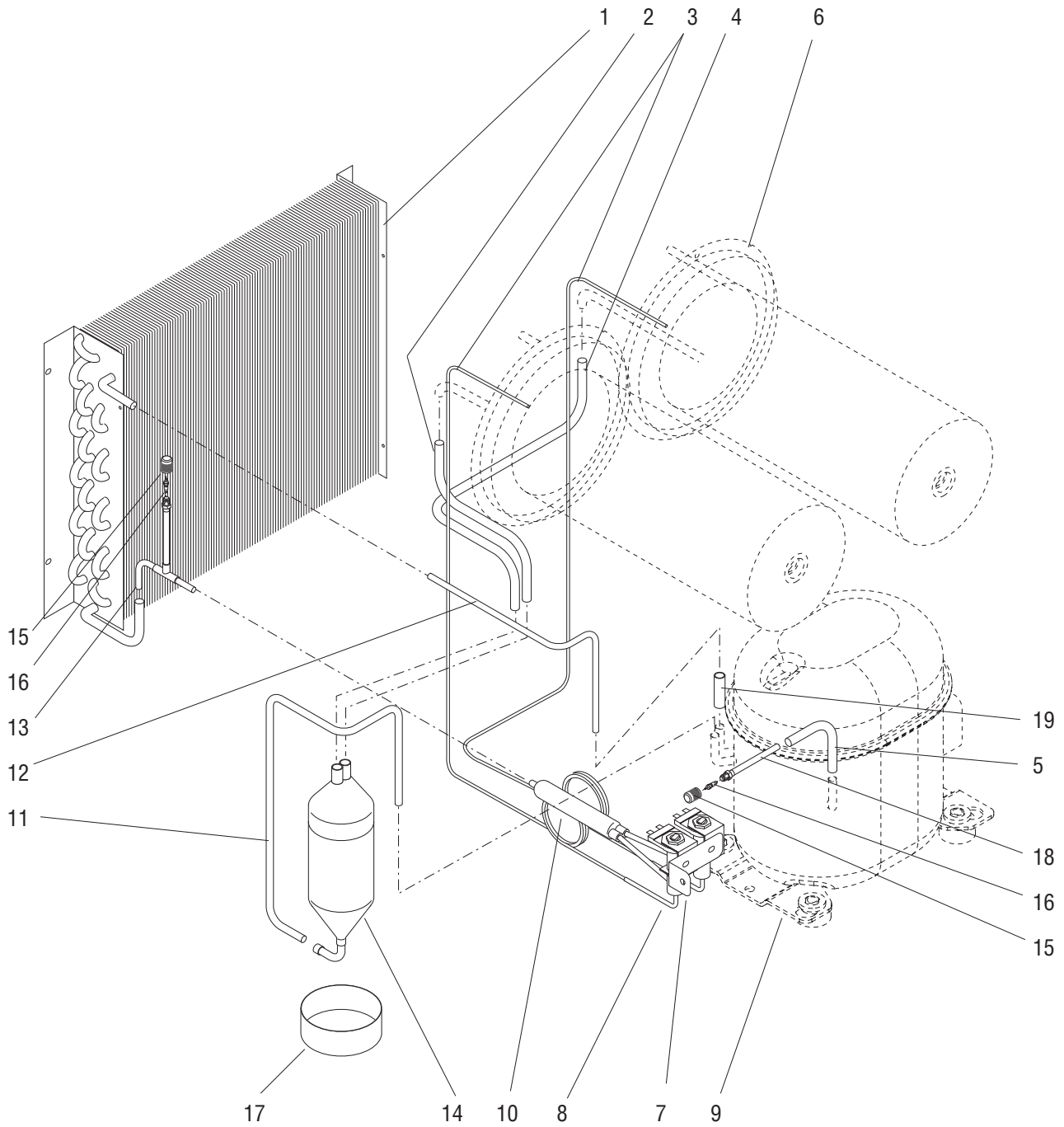

## SOLENOID AND COOLANT PIPING (EMBRACO-230V)

ITEM	PART NO.	QTY.	DESCRIPTION
1	-----	1	Condenser (See Condenser and Fan Mounting)
2	32088.0001	1	Tube .375" O.D. Accumulator to Left Cooling Drum (Requires brazing to install)
3	27607.1000	1	Tube .093" O.D. Solenoid to Left Cooling Drum (Requires brazing to install)
	27607.1001	1	Tube .093" O.D. Solenoid to Right Cooling Drum (Requires brazing to install)
4	32087.0001	1	Tube .375" O.D. Accumulator to Right Cooling Drum (Requires brazing to install)
5	36197.0001	2	Tube, Access Port (Requires brazing to install)
6	-----	2	Cooling Drum (See Auger Drive and Cooling Drum)
7	32113.0000	1	Bracket, Solenoid Mounting
	01317.0003	1	Screw, Truss Head, Locking #8-32 x .38"
8	32133.0000	2	Solenoid Assy (120V)
	32133.0001	2	Solenoid Assy (230V)
	02332.0001	2	Screw, Crimpite #6 x .25"
9	-----	1	Compressor (See Compressor and Mounting)
10	32256.0000	1	Dryer Assembly (Requires brazing to install)
11	36198.0001	1	Tube .312" O.D. Accumulator to Compressor (Requires brazing to install)
12	36196.0001	1	Tube .250" O.D. Condenser to Compressor (Requires brazing to install)
13	34211.0000	1	Tube, Condenser to Dryer (Includes items 15 & 16) (Requires brazing to install)
14	32257.0000	1	Accumulator, Suction (Requires brazing to install)
15	27641.0000	2	Cap, Valve Access
16	27642.0000	2	Valve Core
17	27411.0000	1	Cup, Condensate
18	28645.0000	1	Valve, Access (Includes items 15 & 16) (Requires brazing to install)
19	34256.0001	1	Tube, Spacer (Requires brazing to install)
20	M2316.1000	-	Insulation, Tube .375" I.D. x 6 ft LG (As Required)
21	00617.0000	8	Tie, BLK Nylon 3.90" LG (As Required)
22	03290.0000	7	Tie, WHI Nylon 5.6" LG

} Not Illustrated

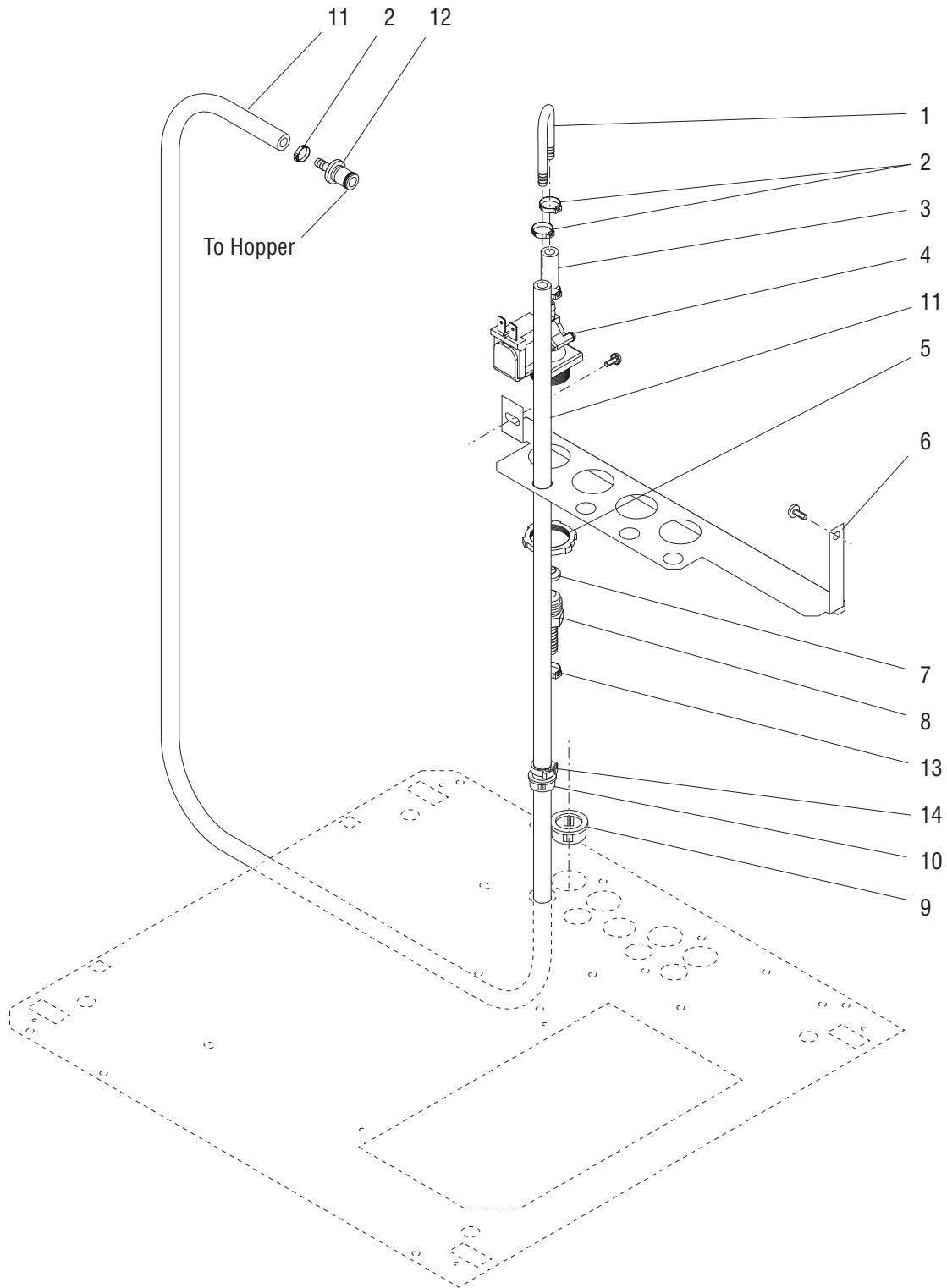

## LIQUID AUTOFILL KIT (Optional)

ITEM	PART NO.	QTY.	DESCRIPTION
Quantities listed below are for one solenoid only. Two to four may required.			
1	37931.0000	1	Tube
2	21275.0006	4	Clamp ,41 - .50"
3	32745.0028	1	Hose .25" ID x 1.0"
4	37933.0000	1	Solenoid, Syrup Valve 120V
	37933.0001	1	Solenoid, Syrup Valve 230V
5	37958.0000	1	Locknut
6	37878.0000	1	Bracket, Autofill
	01311.0001	1	Screw, Truss Head #8-32 x .25" Locking
	02332.0001	1	Screw, Hex Head #6 x .25"
7	33149.0000	1	Gasket
8	35174.0001	1	Fitting .375" Barb x .375" Flare (Product Line)
	35174.0002	1	Fitting .25" Barb x .375" Flare (Water Line)
9	01663.0000	1	Bushing, Snap
10	07070.0000	1	Bushing, Snap
11	32745.0027	1	Hose .25" ID x 55.0"
12	38021.0000	1	Coupling .25" Barb
13	21275.0004	1	Clamp .54 - .64" (Used to attach Product Line)
	21275.0006	1	Clamp .41 - .50" (Used to attach Water Line)
14	12422.0006	1	Clamp .53-.59" ID (Incoming line to valve)
	12422.0011	1	Clamp .40-.45" ID (Outgoing line to hopper)

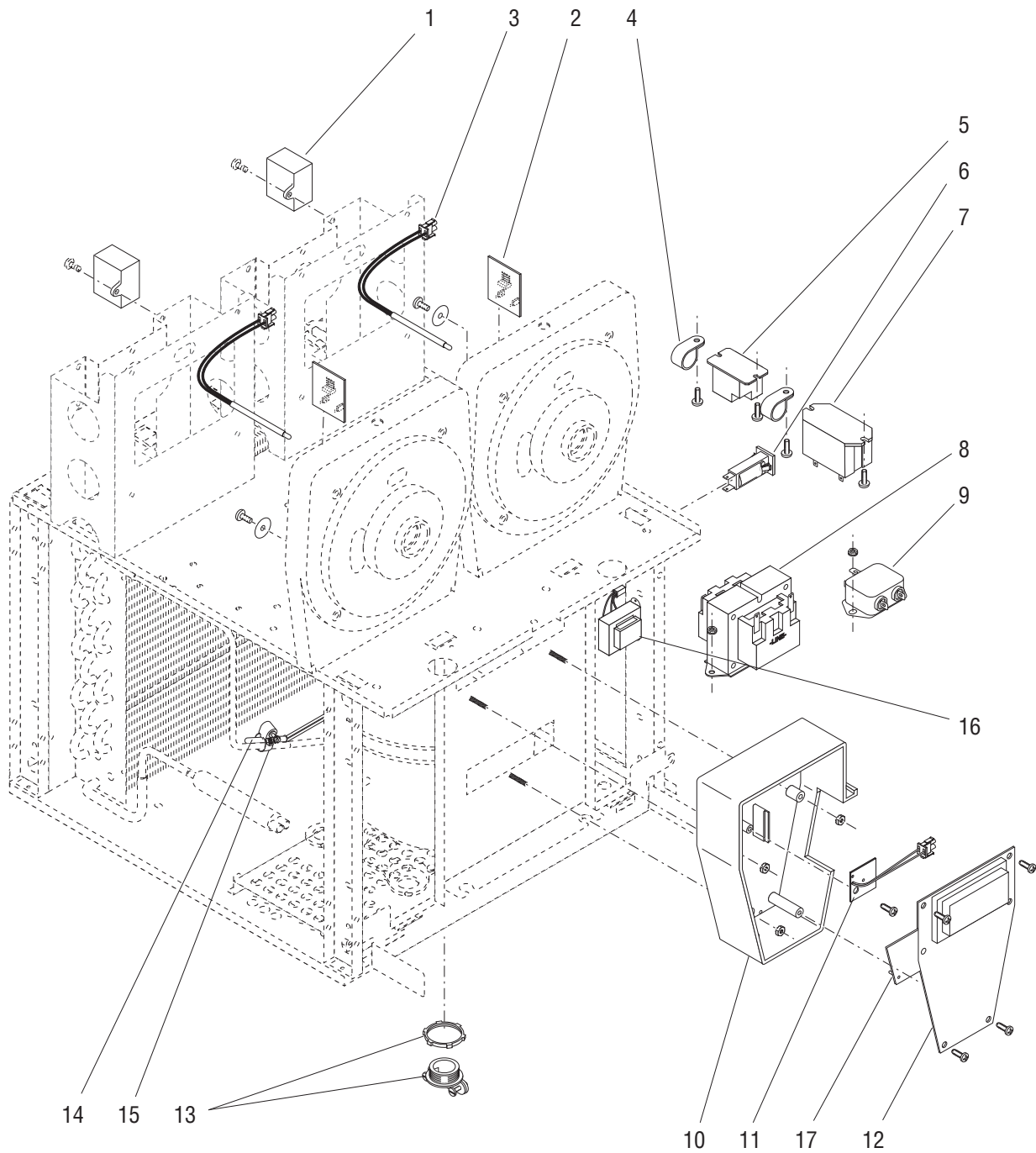



## ELECTRICAL AND OPERATING CONTROLS

ITEM	PART NO.	QTY.	DESCRIPTION
1	27178.0000	2	Capacitor, Auger Motor 370 VAC (120V)
	27178.0001	2	Capacitor, Auger Motor 500 VAC (230V)
2	38708.1000	2	Circuit Board, Torque Sensor
	01317.0003	2	Screw, Truss Head - Locking #8-32 x .375"
	02360.0000	2	Washer, .188" I.D. x .75" O.D.
3	27246.1000	2	Temperature Sensor (Includes Connector)
4	00604.0000	2	Clip
	01317.0003	2	Screw, Truss Head Locking #8-32 x .375"
5	32104.0000	1	Relay, Lighting
	01382.0000	2	Screw, Truss Head #6-32 x .38"
6	27181.0000	1	Circuit Breaker, 5 amp
7	37711.0002	1	Relay, 120V (ULTRA-2)
	37711.0001	1	Relay, 230V (ULTRA-2A)
	01317.0003	2	Screw, Truss Head - Locking #8-32 x .375"
8	27644.1002	1	Transformer, 120V 60 Hz
	27644.1004	1	Transformer, 230V 50/60 Hz
	27644.1005	1	Transformer, 115V (Spanish Models)
	00970.0000	2	Nut, Keps #8-32
9	29446.0001	1	EMI Filter (ULTRA-2A only)
	00970.0000	2	Nut, Keps #8-32
10	32121.0000	1	Box, Electronic Control
	00973.0000	3	Nut, Keps #6-32
11	32097.0001	1	Power Control Board
	24544.0000	1	Screw, Pan Head #8-18
12	32120.1000	1	Electronic Control 120/230V, 50/60Hz
	32120.1002	1	Electronic Control 120/230V, 50/60Hz (Spanish Models)
	38710.1000	1	Circuit Board Assy, Bilingual, Main (Autofill Ready Models)
	24544.0000	4	Screw, Pan Head #8-18
13	05746.0000	1	Bushing, Strain Relief
14	32269.0000	1	Probe, Thermister
15	29421.0001	1	Clamp, Worm Drive
16	28860.0003	1	Transformer, 230V
	01317.0003	2	Screw, Truss Head #8-32 x .38" Locking
	00970.0000	2	Nut, Keps #8-32
17	38983.1000	1	Circuit Board, Autofill (Models with Autofill Option)

The following items are not illustrated:

18	32263.0000	1	Harness, Main (120V)
	32263.0001	1	Harness, Main (230V)
	32263.0002	1	Harness, Main (120V) (Autofill Ready Models)
	32263.0003	1	Harness, Main (230V) (Autofill Ready Models)
	00970.0000	1	Nut, Keps #8-32 (Grounding)
19	32163.0000	1	Harness, Membrane Switch to Electronic Control
20	20630.0009	1	Power Cord 120V
	27728.0006	1	Power Cord 230V
21	37962.0000	1	Harness, Autofill Circuit Board to Syrup Valves (Models with Autofill Option)

## NUMERICAL INDEX

PART NO.	PAGE NO.	PART NO.	PAGE NO.	PART NO.	PAGE NO.	PART NO.	PAGE NO.
00604.0000.....	33	20630.0009.....	33	27446.0000.....	9	29941.1000.....	11
00617.0000.....	15,25,27,29	21275.0004.....	31	27551.0000.....	21	29941.1001.....	11
00707.0000.....	11	21275.0006.....	31	27607.1000.....	25,27,29	29941.1002.....	11
00778.0000.....	9	21436.0000.....	5	27607.1001.....	25,27,29	29941.1003.....	11
00906.0000.....	11,17	21437.1000.....	5	27613.0000.....	21	29942.0000.....	13
00908.0000.....	11,13	22126.0000.....	11	27641.0000.....	21,25,27,29	29942.0001.....	13
00927.0000.....	7	22749.0000.....	13	27642.0000.....	21,25,27,29	29943.0000.....	13
00942.0000.....	17	23700.0000.....	21,23	27643.0000.....	9	29943.0001.....	13
00970.0000.....	33	24566.0000.....	9	27644.1002.....	33	29943.0002.....	13
00973.0000.....	33	24457.0001.....	11	27644.1004.....	33	29943.0003.....	13
00986.0002.....	5,13	24544.0000.....	33	27644.1005.....	33	29947.0000.....	5,11
01311.0001.....	5,11,13,15,31	26528.0000.....	7	27728.0006.....	33	29948.0000.....	13
01315.0000.....	9,13	26781.0000.....	15	27748.0000.....	11,17	29948.0001.....	13
01317.0000.....	13	26791.0000.....	19	27788.0000.....	11,17	29959.0001.....	7
01317.0001.....	15	27058.0000.....	5	28027.0000.....	15	29959.0002.....	7
01317.0003.....	5,15,19,25	27058.0001.....	7	28081.0001.....	15	29959.8002.....	7
01317.0003.....	27,29,33	27058.0002.....	5	28086.0000.....	5	29967.0000.....	5
01326.0002.....	15	27058.0003.....	7	28086.0001.....	5	29976.0000.....	7
01330.0000.....	11	27131.0000.....	7	28093.1000.....	15	29979.0000.....	5
01370.0000.....	11	27131.0001.....	7	28093.1001.....	15	32068.0000.....	5
01382.0000.....	7,11,33	27136.0002.....	5	28098.0000.....	7	32068.0001.....	5
01393.0000.....	9	27136.0003.....	5	28111.0005.....	13	32073.1000.....	21
01501.0000.....	15	27178.0000.....	33	28122.0000.....	19	32079.0000.....	15
01511.0000.....	15	27178.0001.....	33	28236.0000.....	15	32082.0000.....	5
01521.0000.....	13	27179.1000.....	15	28645.0000.....	27,29	32082.0001.....	5
01522.0001.....	11	27179.1001.....	15	28651.0000.....	21,23	32082.0002.....	5
01532.0001.....	9	27180.0000.....	19	28755.0003.....	9	32082.0003.....	5
01663.0000.....	13,31	27181.0000.....	33	28756.0000.....	9	32084.0000.....	19
01666.0002.....	11	27219.0000.....	19	28770.0000.....	9	32084.0001.....	19
02308.0000.....	19	27220.0000.....	19	28776.0000.....	9	32084.0002.....	19
02322.0000.....	13	27221.0000.....	19	28860.0003.....	33	32085.0001.....	25
02329.0000.....	5	27223.0000.....	15	28925.0000.....	25,27	32086.0001.....	25
02332.0001.....	19,25,27,29,31	27224.0000.....	15	29084.0000.....	19	32087.0001.....	25,27,29
02332.0002.....	19,21	27228.0000.....	15	29084.0001.....	19	32088.0001.....	25,27,29
02335.0001.....	21	27231.0000.....	15	29159.0000.....	19	32091.0000.....	17
02360.0000.....	33	27231.0001.....	15	29160.0000.....	19	32091.0001.....	17
03290.0000.....	25,27,29	27232.0000.....	15	29160.0001.....	19	32091.0002.....	17
03354.0000.....	7	27243.0000.....	19	29373.0000.....	7	32091.0003.....	17
03628.0000.....	11	27246.1000.....	33	29421.0001.....	33	32092.0000.....	15
03851.0000.....	9,13	27257.0000.....	19	29446.0001.....	13,33	32092.0001.....	15
03993.0000.....	7	27258.0000.....	19	29481.0000.....	9	32092.0002.....	15
03996.0000.....	7	27394.0000.....	5	29591.0001.....	11	32092.0003.....	15
05746.0000.....	11,33	27394.0001.....	5	29591.0002.....	11	32094.0000.....	21
07070.0000.....	31	27403.0000.....	21	29702.1000.....	7	32095.0000.....	21
11556.0001.....	15	27404.0000.....	21	29724.0000.....	11	32096.0001.....	9
12421.1001.....	7	27405.0001.....	21	29726.0000.....	11	32097.0001.....	33
12421.1002.....	7	27406.0002.....	21	29742.0000.....	11	32101.1000.....	5
12421.1003.....	7	27407.0000.....	21	29763.0000.....	13	32101.1002.....	5
12422.0006.....	31	27407.0001.....	21	29844.0000.....	11	32101.1004.....	5
12422.0011.....	31	27408.0000.....	21	29844.0001.....	11	32101.1006.....	5
13255.0003.....	7	27411.0000.....	25,27,29	29932.1000.....	21	32104.0000.....	11,33
13255.0006.....	7	27440.0001.....	15	29936.0000.....	13	32105.0000.....	9
20622.0005.....	7	27442.0000.....	5	29940.0000.....	11	32105.0001.....	9
20630.0007.....	13	27445.1000.....	9	29940.0002.....	11	32106.1000.....	15

## NUMERICAL INDEX

PART NO.	PAGE NO.	PART NO.	PAGE NO.	PART NO.	PAGE NO.	PART NO.	PAGE NO.
32108.0000.....	15	33527.0000.....	11				
32111.0000.....	5	34211.0000.....	25,27,29				
32111.0001.....	5	34251.0000.....	23				
32111.0002.....	5	34252.0001.....	23				
32111.0003.....	5	34253.0000.....	23				
32113.0000.....	25,27,29	34254.0002.....	23				
32116.1000.....	5	34255.0002.....	23				
32116.1001.....	5	34256.0001.....	27,29				
32120.1000.....	33	34257.0001.....	27				
32120.1002.....	33	34258.0001.....	27				
32121.0000.....	33	34296.1000.....	23				
32124.0000.....	7	34529.0000.....	21,23				
32126.0001.....	5	34573.0000.....	13				
32133.0000.....	25,27,29	34575.0000.....	13				
32133.0001.....	25,27,29	34836.0000.....	15				
32162.0000.....	7	34836.0001.....	15				
32163.0000.....	33	35174.0001.....	31				
32189.0000.....	9	35174.0002.....	31				
32190.1000.....	9	35980.1000.....	23				
32190.1001.....	9	36182.1000.....	5				
32190.1002.....	9	36182.1001.....	7				
32190.1003.....	9	36182.1002.....	5				
32191.0000.....	9	36182.1003.....	7				
32193.0000.....	9	36187.0000.....	7				
32195.0000.....	9	36188.0000.....	7				
32196.1000.....	9	36196.0001.....	29				
32196.1001.....	9	36197.0001.....	29				
32197.0000.....	11	36198.0001.....	29				
32212.0001.....	13	37593.0000.....	15				
32256.0000.....	25,27,29	37711.0001.....	33				
32257.0000.....	25,27,29	37711.0002.....	33				
32263.0000.....	33	37878.0000.....	31				
32263.0001.....	33	37883.0000.....	7				
32263.0002.....	33	37906.0000.....	7				
32263.0003.....	33	37931.0000.....	31				
32265.0001.....	9	37933.0000.....	31				
32266.0000.....	9	37933.0001.....	31				
32267.1000.....	9,13	37955.0000.....	17				
32268.0000.....	9	37958.0000.....	31				
32269.0000.....	33	37962.0000.....	33				
32449.0000.....	15	38021.0000.....	31				
32580.0000.....	5,7	38708.1000.....	33				
32632.0000.....	11	38710.1000.....	33				
32745.0027.....	31	38983.1000.....	33				
32745.0028.....	31	39055.0001.....	9				
32793.0000.....	7	39134.0000.....	23				
32795.0002.....	23	39136.0000.....	23				
32797.0000.....	23	39137.0000.....	23				
32798.0000.....	23	39142.0000.....	23				
32799.0002.....	23	39152.0000.....	23				
33149.0000.....	31	M2316.1000 .....	25,27,29				
33176.0001.....	9	M2548.1000 .....	15				
33524.0000.....	11						
33525.0000.....	11						