

BUNN®

U3

U3A

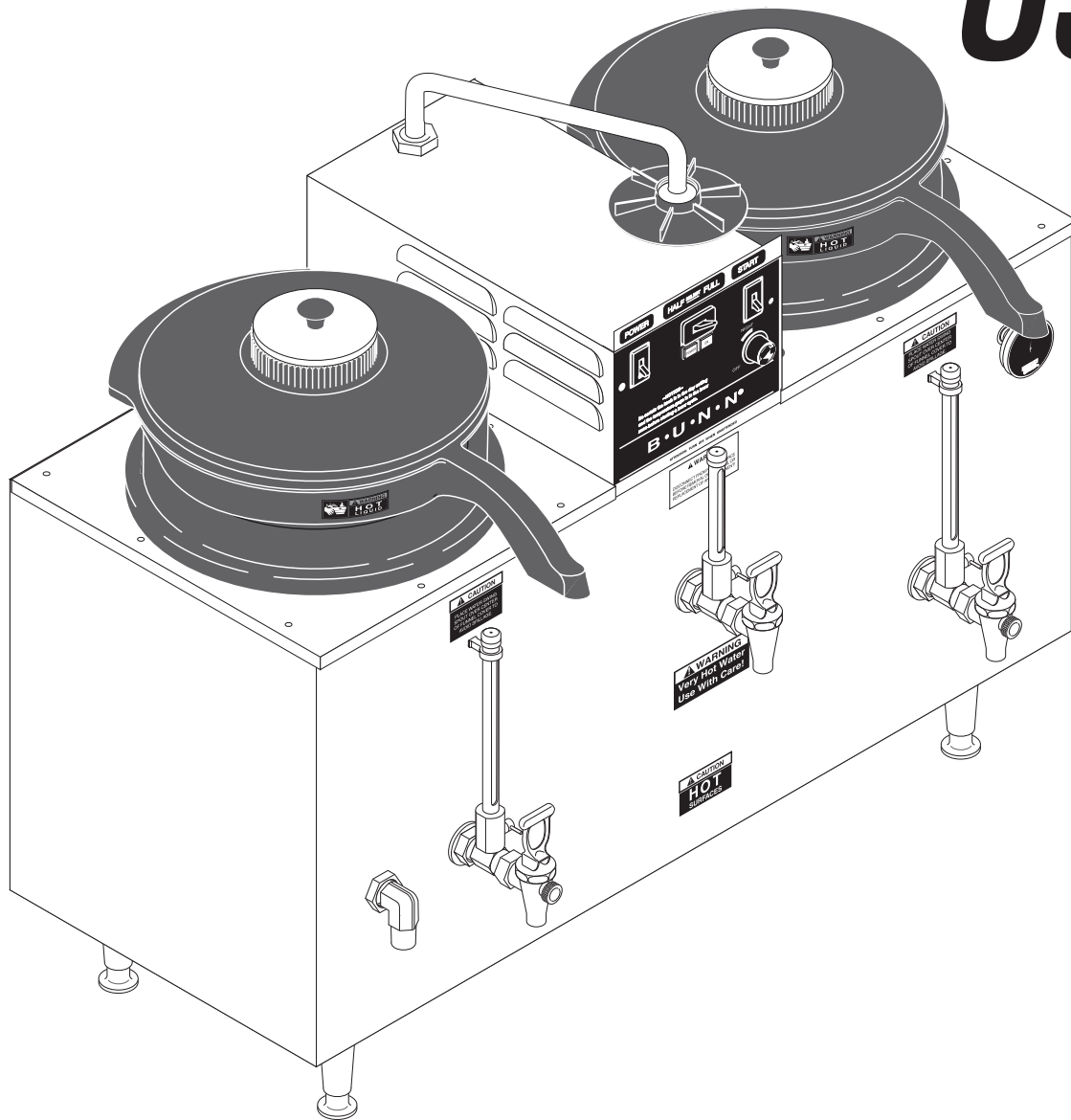

OPERATING & SERVICE MANUAL

BUNN-O-MATIC CORPORATION

POST OFFICE BOX 3227

SPRINGFIELD, ILLINOIS 62708-3227

PHONE: (217) 529-6601 FAX: (217) 529-6644

INTRODUCTION

This brewer will brew a three gallon batch of coffee into each reservoir (one at a time). Each reservoir has its own dispensing faucet(s). The brewer also has a hot water faucet(s) for allied beverage use. It is only for indoor use on a sturdy counter where ambient temperature is in the range of 10-30°C (50-85°F). Brewer to be installed at a location where it can be overseen by trained personnel.

BUNN-O-MATIC COMMERCIAL PRODUCT WARRANTY

Bunn-O-Matic Corp. ("BUNN") warrants equipment manufactured by it as follows:

- 1) All equipment other than as specified below: 2 years parts and 1 year labor.
- 2) Electronic circuit and/or control boards: parts and labor for 3 years.
- 3) Compressors on refrigeration equipment: 5 years parts and 1 year labor.
- 4) Grinding burrs on coffee grinding equipment to grind coffee to meet original factory screen sieve analysis: parts and labor for 3 years or 30,000 pounds of coffee, whichever comes first.

These warranty periods run from the date of installation BUNN warrants that the equipment manufactured by it will be commercially free of defects in material and workmanship existing at the time of manufacture and appearing within the applicable warranty period. This warranty does not apply to any equipment, component or part that was not manufactured by BUNN or that, in BUNN's judgment, has been affected by misuse, neglect, alteration, improper installation or operation, improper maintenance or repair, damage or casualty. This warranty is conditioned on the Buyer 1) giving BUNN prompt notice of any claim to be made under this warranty by telephone at (217) 529-6601 or by writing to Post Office Box 3227, Springfield, Illinois 62708-3227; 2) if requested by BUNN, shipping the defective equipment prepaid to an authorized BUNN service location; and 3) receiving prior authorization from BUNN that the defective equipment is under warranty.

THE FOREGOING WARRANTY IS EXCLUSIVE AND IS IN LIEU OF ANY OTHER WARRANTY, WRITTEN OR ORAL, EXPRESS OR IMPLIED, INCLUDING, BUT NOT LIMITED TO, ANY IMPLIED WARRANTY OF EITHER MERCHANTABILITY OR FITNESS FOR A PARTICULAR PURPOSE. The agents, dealers or employees of BUNN are not authorized to make modifications to this warranty or to make additional warranties that are binding on BUNN. Accordingly, statements by such individuals, whether oral or written, do not constitute warranties and should not be relied upon.

If BUNN determines in its sole discretion that the equipment does not conform to the warranty, BUNN, at its exclusive option while the equipment is under warranty, shall either 1) provide at no charge replacement parts and/or labor (during the applicable parts and labor warranty periods specified above) to repair the defective components, provided that this repair is done by a BUNN Authorized Service Representative; or 2) shall replace the equipment or refund the purchase price for the equipment.

THE BUYER'S REMEDY AGAINST BUNN FOR THE BREACH OF ANY OBLIGATION ARISING OUT OF THE SALE OF THIS EQUIPMENT, WHETHER DERIVED FROM WARRANTY OR OTHERWISE, SHALL BE LIMITED, AT BUNN'S SOLE OPTION AS SPECIFIED HEREIN, TO REPAIR, REPLACEMENT OR REFUND.

In no event shall BUNN be liable for any other damage or loss, including, but not limited to, lost profits, lost sales, loss of use of equipment, claims of Buyer's customers, cost of capital, cost of down time, cost of substitute equipment, facilities or services, or any other special, incidental or consequential damages.

BUNN and U3 are either trademarks or registered trademarks of Bunn-O-Matic Corporation.

USER NOTICES

Carefully read and follow all notices on the brewer and in this manual. They were written for your protection. All notices on the brewer are to be kept in good condition. Replace any unreadable or damaged labels.

 WARNING
<ul style="list-style-type: none">◆ Fill water tank before turning - on - thermostat or connecting appliance to power source.◆ Use only on a properly protected circuit capable of the rated load.◆ Electrically ground the chassis.◆ Follow national/local electrical codes.◆ Do not use near combustibles.
FAILURE TO COMPLY RISKS EQUIPMENT DAMAGE, FIRE, OR SHOCK HAZARD
READ THE ENTIRE OPERATING MANUAL BEFORE BUYING OR USING THIS PRODUCT
THIS APPLIANCE IS HEATED WHENEVER CONNECTED TO A POWER SOURCE
<small>00831.0000F 3/98 ©1998 BUNN-O-MATIC CORPORATION</small>

#00831.0000

ATTENTION: TURN OFF WHEN UNATTENDED

#00878.0000

This equipment must be installed to comply with the Basic Plumbing Code of the Building Officials and Code Administrators International, Inc. (BOCA) and the Food Service Sanitation Manual of the Food and Drug Administration (FDA). For models installed outside the U.S.A., comply with the applicable Plumbing /SanitationCode.

#00656.0000

 WARNING
Disconnect from power source before removal of any panel or replacement of any component!

#10044.0000

 WARNING
<u>Very Hot Water</u>
Use With Care!

#12593.0000

	<table border="1"><thead><tr><th> WARNING</th></tr></thead><tbody><tr><td>REMOVE FUNNEL SLOWLY</td></tr></tbody></table>	 WARNING	REMOVE FUNNEL SLOWLY
 WARNING			
REMOVE FUNNEL SLOWLY			

#03408.0000

	<table border="1"><thead><tr><th> WARNING</th></tr></thead><tbody><tr><td>HOT LIQUID</td></tr></tbody></table>	 WARNING	HOT LIQUID
 WARNING			
HOT LIQUID			

#03409.0000

 CAUTION
HOT SURFACES

#12555.0000

ELECTRICAL REQUIREMENTS

CAUTION - The brewer must be disconnected from the power source until specified in Initial Set-Up.

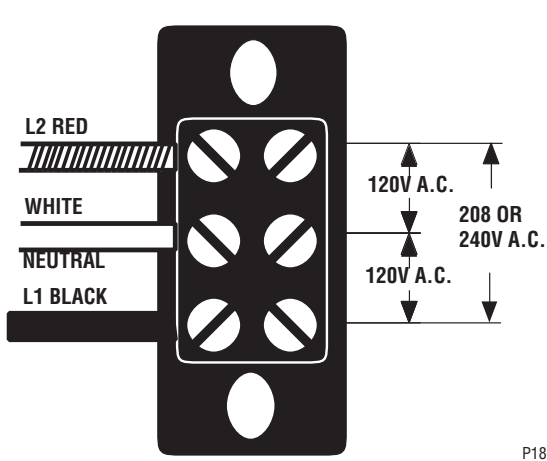

P1841

U3 & U38 requires 3-wire, grounded service rated 120/208 or 120/240 volts ac, U3-30 amp, U38-40 amp, single phase, 60 Hz. Proceed as follows:

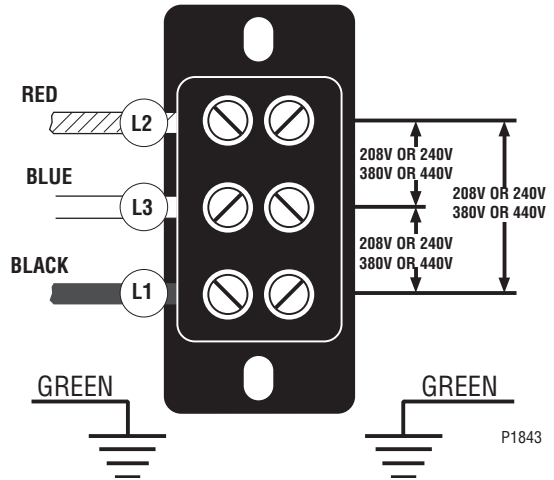

P1843

U333 & U3833 requires 3-wire, grounded service rated 240 volt ac, 35 amp or 440 volts ac, 30 amp for U333, three phase, 60 Hz or 380 volts ac, 30 amp for U3833, three phase, 50 Hz. Proceed as follows:

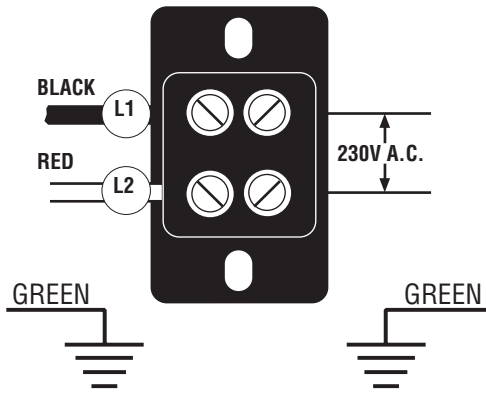

P1842

U3A models require 2-wire, grounded service rated 230 volts ac, 30 amp, single phase, 50 Hz. Proceed as follows:

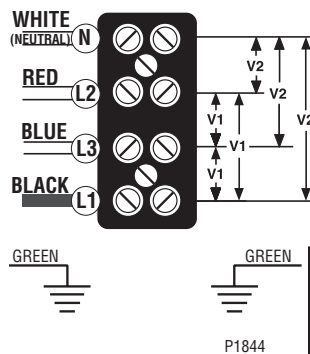

P1844

L1, L2, L3, are the 3 phases

V1 = Phase to phase voltage, between any 2 phases.

V2 = Phase to neutral voltage, any phase to neutral.

SYSTEM VOLTAGE	V1	V2
208	208	120
240	240	139
380	380	220
440	440	254

U3833 requires 4-wire, grounded service rated 380 volts ac or 440 volts ac, 30 amp, three phase, 50 Hz. Proceed as follows:

ELECTRICAL INSTALLATION INSTRUCTIONS

NOTE: Electrical source should have a circuit breaker between the brewer and the main supply which breaks all poles with a contact separation of at least 3 mm.

CAUTION – Improper electrical installation will damage electronic components.

1. An electrician must provide electrical service as specified.
2. Using a voltmeter, check the voltage and color coding of each conductor at the electrical source.
3. Before electrically connecting the brewer, remove the front cupola cover (some models have the thermostat knob on the outside of the cover) and rotate the thermostat knob fully counterclockwise to the "OFF" position. Keep this knob in the "OFF" position until performing the **Initial Setup**.
4. Electrical service is connected at the upper rear of the single service and scrambler brewers using a junction box. On double service brewers the rear decorative channel must be removed for access to the terminal block.
5. Connect the brewer to the power source and verify the voltage at the terminal block before proceeding. Replace all panels.

ELECTRICAL INSTALLATION INSTRUCTIONS (CONT.)

6. If plumbing is to be hooked up later be sure the brewer is disconnected from the power source. If plumbing has been hooked up, the brewer is ready for **Initial Setup**.

NOTE: Schematic wiring diagrams are included in this manual.

PLUMBING REQUIREMENTS

These brewers must be connected to a cold water system with operating pressure between 20 (138) and 90 psi (620 kPa) from a 1/2" or larger supply line. A shut-off valve should be installed in the line before the brewer. Install a regulator in the line when pressure is greater than 90 psi (620 kPa) to reduce it to 50 psi (345 kPa). The water inlet fitting is 3/8" flare.

NOTE - Bunn-O-Matic recommends 3/8" copper tubing for installations from the 1/2" water supply line. A tight coil of copper tubing in the water line will facilitate moving the brewer to clean the countertop. Bunn-O-Matic does not recommend the use of a saddle valve to install the brewer. The size and shape of the hole made in the supply line by this type of device may restrict water flow.

This equipment must be installed to comply with the Basic Plumbing Code of the Building Officials and Code Administrators International, Inc. (BOCA) and the Food Service Sanitation Manual of the Food and Drug Administration (FDA). For models installed outside the U.S.A., you must comply with the applicable Plumbing/Sanitation Code for your area.

INITIAL SETUP

CAUTION - The brewer must be disconnected from the power source throughout the initial setup, except when specified in the instructions.

IMPORTANT: Brewer must be level and installed on a sturdy structure.

Electrician's and Plumber's Instructions are provided. These instructions should be carefully followed before proceeding with initial setup.

Be sure all electrical and plumbing connections are tight.

1. Open manual fill valve located on the bottom of the brewer. Water should start filling the tank. When water is visible in the hot water gauge glass (center spigot), close valve. Approximate time for filling manually is 3 minutes.

CAUTION: Never leave brewer unattended while manually filling tank.

2. Connect the brewer to the power source. Turn "ON/OFF" switch to the "ON" position. Water should finish filling tank automatically.

NOTE: It is recommended that the "ON/OFF" switch be left in the "OFF" position at the end of the operating day or when unattended for a long period of time.

3. Disconnect the brewer from the power source. Remove front cupola cover for access to thermostat knob and timer. On some brewers the thermostat knob is located on the front of the cupola cover.
4. Turn the thermostat knob clockwise to an approximate 5 o'clock position. Allow 1-1/2 hours for water to heat. Time will vary with incoming water temperature.
5. On initial warm-up, some water may flow thru the overflow spigot due to expansion of the cold water in the tank. This will not recur during the use of the brewer and may be avoided on the initial warm-up by drawing off 1/2 gallon decanters of water each 15 minutes till brewing temperature is reached.

INITIAL SETUP (cont.)

6. Brewing cycles may be started whenever water temperature is correct. This condition is indicated by the dial thermometer on front of the brewer. Whenever the pointer is in the green, brewer is ready for brewing. The recommended brewing temperature is approximately 200°F (93°C). Water temperature may be increased by turning thermostat knob clockwise, decreased by turning knob counterclockwise.
7. When desired temperature is reached, insert funnel support, funnel and funnel cover in position. Be sure the water swing spout is over the center of the funnel cover, turn "ON/OFF" switch to the "ON" position, push and release "START" and run a brew cycle of hot water only. At the end of this cycle, brewer will be ready for checking timer adjustment.
8. The timer has been preset for a 4 minute cycle. This setting will deliver approximately 3 gallons of water per brewing cycle. To increase or decrease amount of water, adjust the timer as required. See **Adjusting Brew Volumes**.
9. Having determined final settings of the thermostat and the timer, replace front cupola cover. Brewer is now ready for brewing coffee.

ADJUSTING BREW VOLUMES

CAUTION - Disconnect the power source from the brewer prior to the removal of any panel for the replacement or adjustment of any component.

NOTE: Prior to setting or modifying batch sizes, check that the brewer is connected to water supply, the tank is properly filled, and a funnel support, funnel and funnel cover are in place.

1. **Modifying batch sizes.** To modify a batch volume, first check that the SET/LOCK switch is in the "SET" position on the circuit board.

To increase a batch size. Press and hold the START or BREW switch until you see three breaks in the water stream from the swing arm. Release the switch (Failure to release the switch within two seconds after the third break in the water stream causes the volume setting to be aborted and previous volume setting will remain in memory) and press it again one or more times. Each time the switch is pressed, two seconds are added to the brew time period. Allow the brew cycle to finish in order to verify that the desired volume has been achieved.

To decrease a batch size. Press and release the START or BREW switch once for every two-second interval to be removed from the total brew time period; then immediately press and hold down the START or BREW switch until you see three breaks in the water stream from the swing arm. Release the switch. (Failure to release the switch within two seconds after the third break in the water stream causes the volume setting to be aborted and previous volume setting will remain in memory). Allow the brew cycle to finish in order to verify that the desired volume has been achieved.

2. **Setting batch sizes.** To set a batch volume, first check that the SET/LOCK switch is in the "SET" position on the circuit board. Press and hold the START or BREW switch until you see three breaks in the water stream from the swing arm, and then release the switch. (Failure to release the switch within two seconds after the third break in the water stream causes the volume setting to be aborted and previous volume setting will remain in memory). View the level of the liquid being dispensed. When the desired level is reached, turn the ON/OFF switch to "OFF" (lower). The brewer remembers this volume and will continue to brew batches of this size until the volume setting procedure is repeated.

NOTE: When brewing coffee, batch volumes will decrease due to absorption by the coffee grounds.

NOTE: HALF-BATCH AND FULL BATCH SETTINGS MUST EACH BE SET SEPARATELY.

3. **Setting programming disable feature.** If it becomes necessary to prevent anyone from changing brew times once programmed, you can set the SET/LOCK switch to the "LOCK" position. This will prevent any programming to be done until switch is once again placed in the "SET" position.

COFFEE BREWING

1. Brewing cycles may be started whenever water temperature is correct. This condition is indicated by the dial thermometer on front of the brewer. Whenever the pointer is in the green, brewer is ready for brewing.
2. Insert Bunn® filter in funnel and add desired amount of coffee.
3. Level the bed of coffee and place funnel into the funnel support. Place funnel cover over the funnel and be sure the water swing spout is over the center of the funnel cover.
4. Turn "ON/OFF" switch to the "ON" position.
5. Push and release "START" switch to start the brew cycle.
6. Water swing spout should not be moved as long as water is flowing into the funnel cover. When water stops flowing, it may then be moved for access to brewing funnel.
7. Remove funnel cover. Funnel should not be removed from brewer until drip out of coffee has been completed.
8. To empty funnel, invert it over a waste container to dispose of filter and grounds. An additional flange is provided on the funnel to help make this step easier.

NOTE: Hot water may be drawn from the hot water faucet during a brew cycle. However, if a large amount of hot water is drawn off (over 1 gallon) operator should wait to do so between brewing cycles.

CLEANING

NOTE: Tanks and tank components should be delimed regularly based on local water conditions. Excessive mineral build-up on stainless steel surfaces can initiate corrosion reactions resulting in serious leaks.

1. Remove both funnels, funnel lids and supports, under hot water, rinse away all coffee oils. Wipe with a clean damp cloth.
2. Drain both coffee reservoirs by opening coffee faucets. When empty, close faucets.
3. Cycle two or three inches of water into each coffee reservoir and scrub entire reservoir area.

NOTE: The brewer must **NOT** be rinsed or cleaned by a water jet device.

4. Drain both coffee reservoirs and rinse. Use clean damp cloth to wipe both reservoirs.
5. Install both coffee funnel supports, funnels and funnel lids.
6. Remove the sight gauge cap, insert sight gauge cleaning brush into the sight gauge glass tube and clean.
7. To clean coffee faucets, remove the faucet handle from the faucet and faucet clean out cap. Clean faucet with a faucet cleaning brush and wipe all parts with a damp cloth. Replace faucet seat cups periodically if badly stained or to stop faucet dripping. **DO NOT CLEAN THE HOT WATER FAUCET.**
8. Reassemble the coffee faucets.
9. Wipe the entire outside surface of the machine with a clean damp cloth. Wipe dry.

FILTER HOLDER

1. A filter holder is supplied with each U3 coffee brewer. Its purpose is to keep the filters in their originally formed shape to properly fit the brewer funnel.
2. It is suggested that only one cluster of filters be placed in the holder at one time for best results.
3. Not using the filter holder may permit the filters to gradually widen out towards a flat shape, especially so if humidity is present. Once a filter has lost its upright side walls, it may tend to collapse inward when placed in the brewing funnel. If this happens the hot water spray may cause one side to fall inwards, letting coffee grounds flow over the edge of filter and into the brewed coffee. Proper use of the holder should prevent this problem.

TROUBLESHOOTING

A troubleshooting guide is provided to suggest probable causes and remedies for the most likely problems encountered. If the problem remains after exhausting the troubleshooting steps, contact the Bunn-O-Matic Technical Service Department.

- Inspection, testing, and repair of electrical equipment should be performed only by qualified service personnel.
- All electronic components have 120 volt ac and low voltage dc potential on their terminals. Shorting of terminals or the application of external voltages may result in board failure.
- Intermittent operation of electronic circuit boards is unlikely. Board failure will normally be permanent. If an intermittent condition is encountered, the cause will likely be a switch contact or a loose connection at a terminal or crimp.
- Solenoid removal requires interrupting the water supply to the valve. Damage may result if solenoids are energized for more than ten minutes without a supply of water.
- The use of two wrenches is recommended whenever plumbing fittings are tightened or loosened. This will help to avoid twists and kinks in the tubing.
- Make certain that all plumbing connections are sealed and electrical connections tight and isolated.
- This brewer is heated at all times. Keep away from combustibles.

- WARNING** –
- Exercise extreme caution when servicing electrical equipment.
 - Unplug the brewer when servicing, except when electrical tests are specified.
 - Follow recommended service procedures
 - Replace all protective shields or safety notices

PROBLEM	PROBABLE CAUSE	REMEDY
Brew cycle will not start	1. No water	Water lines and valves to the brewer must be open.
	2. No power or incorrect voltage to the brewer	(A1) Check the terminal block for 120 volts ac across the red and white terminals and the black and white terminal on three wire 102/208 volt or 120/240 volt models. (A2) Check the terminal block for 208 volts ac, 230 volts ac or 240 volts ac on "A Series" brewers across the red and black terminals on two wire single phase 208 volt, 230 volt and 240 volt models. (A3) Check the terminal block for 208 volts ac, 240 volts ac, 380 volts ac across the black and blue terminals, the blue and red and the black and red terminals on three wire three phase 208 volt, 240 volt and 380 volt models.

TROUBLESHOOTING (cont.)

PROBLEM

PROBABLE CAUSE

REMEDY

Brew cycle will not start (cont)

2. No power or incorrect voltage to the brewer (cont)

(A4) Check the terminal block for 440 volts ac across the black and blue terminals, black and red terminals and the red and blue terminals on four wire three phase 440 volt models.
(B) Check circuit breakers or fuses.

3. Water level below pump housing. (Water level in the hot water gauge glass should be approximately half full).

Be sure water shut-off valve is open and that the in-line filters or strainers are not blocking water flow. (Do not confuse water shut-off valve with the manual fill and drain valve underneath the brewer).

4. ON/OFF Switch

Refer to Service - ON/OFF Switch for testing. See page 22

5. Start Switch

Refer to Service - Start Switches for testing procedures. See page 29

6. Relay

Refer to Service - Relay for testing procedures. See page 24

7. Timer

Refer to Service - Timer for testing procedures. See page 31 or 33

8. Pump

Refer to Service - Pump for testing procedures. See page 23

9. Solenoid Valve

Refer to Service - Solenoid Valve for testing procedures. See page 27

10. Strainer

(A) Direction of flow arrow must be pointing towards brewer.

(B) Remove the strainer and check for obstructions. Clear or replace.

Brew cycle starts with brew lockout relay engaged.

1. Relay

Refer to Service - Relay for testing procedures. See page 24

TROUBLESHOOTING (cont.)

PROBLEM

Tank not filling

PROBABLE CAUSE

1.ON/OFF Switch (This switch must be in the "ON" position for the refill circuit to operate.

2. No water

3. Solenoid Valve

4. Probe

5. Liquid Level Board

REMEDY

Refer to Service - ON/OFF Switch for testing procedures. See page 22

Be sure water shut-off is open and that in-line filters or strainers are not blocking water flow. (Do not confuse water shut-off valve with the manual fill and drain valve underneath brewer).

Refer to Service - Solenoid Valve for testing procedures. See page 27

Refer to Service - Probe for testing procedures. See page 20

Refer to Service - Liquid Level Board for testing procedures. See page 20

Water running out of the overflow

1.Brewer not level

2. Solenoid Valve

3. Liquid Level Board

4. Probe

5. Manual fill and drain valve underneath brewer open.

Brewer must be level and installed on a sturdy structure.

Refer to Service - Solenoid Valve for testing procedures. See page 27

Refer to Service -Liquid Level Board for testing procedures. See page 20

Refer to Service - Probe for testing procedures. See page 20

Be sure valve is closed.

TROUBLESHOOTING (cont.)

PROBLEM

PROBABLE CAUSE

REMEDY

Water not hot

1. Limit Thermostat
CAUTION - Do not eliminate or bypass limit thermostat. Use only Bunn-O-Matic replacement part #29329.1000

Refer to Service - Limit Thermostat for testing procedures. See page 19

2. Control Thermostat

Refer to Service - Control Thermostat for testing procedures. See page 17

3. Tank Heater(s)

Refer to Service - Tank Heater for testing procedures. See page 30

4. Contactor

Refer to Service - Contactor for testing procedures. See page 15

Circuit breaker keeps tripping

1. Circuit Breaker

Refer to Service - Circuit Breaker for testing procedures. See page 14

2. Tank Heater(s)

Refer to Service - Tank Heater for testing procedures. See page 30

Water keeps running from swing spout

1. Timer

Refer to Service - Timer for testing procedures. See page 31 or 33

2. Start Switch

Refer to Service - Start Switch for testing procedures. See page 29

Inconsistent coffee yield

1. Timer

Refer to Service - Timer for testing procedures. See page 31 or 33

2. Solenoid Valve

Refer to Service - Solenoid Valve for testing procedures. See page 27

3. Lime build-up in swing spout and pump tubing.

Remove swing spout and insert delimiting rod down into pump tubing as far as possible.

Funnels overflow

1. Filters

Use Bunn® filters made for the U3 brewer.

2. Hole in bottom of funnel obstructed.

Remove obstruction.

TROUBLESHOOTING (cont.)

PROBLEM

PROBABLE CAUSE

REMEDY

Funnels overflow (cont.)

3. Pump - Flow Rate

Check pump flow rate with a watch. Pump flow rate should be approximately 24 ounces in 15 seconds. Be sure pump assembly is free of any obstructions.

4. Soft Water

When using a water softener, a coarse grind of coffee may be preferred. If required, a bypass system is available as an optional feature.

Coffee reservoir overflows

1. Coffee reservoir not completely empty before a brew cycle was started.

Be sure coffee reservoir is empty before brew cycle is started.

2. Timer

Refer to Service -Timer for testing procedures. See page 31 or 33

3. Pump - Flow Rate

Check pump flow rate with a watch. Pump flow rate should be approximately 24 ounces in 15 seconds. Be sure pump assembly is free of any obstructions.

Brewer is making unusual noises

1. Solenoid Valve

The nut on the solenoid must be tight or it will vibrate during operation.

2. Plumbing lines

Plumbing lines should not be resting on the counter top.

3. Water supply

(A) The brewer must be connected to a cold water line.

(B) Water pressure to the brewer must not exceed 90 psi (620 kPa). Install a regulator if necessary to lower the pressure to approximately 50 psi (345 kPa).

4. Tank Heater(s)

Remove and clean lime off the tank heater. See page 30

SERVICE

This section provides procedures for testing and replacing various major components used in this brewer should service become necessary. Refer to **Troubleshooting** for assistance in determining the cause of any problem.

WARNING - Inspection, testing, and repair of electrical equipment should be performed only by qualified service personnel. The brewer should be unplugged when servicing, except when electrical tests are required and the test procedure specifically states to plug in the brewer.

COMPONENT ACCESS

WARNING - Disconnect the brewer from the power source before the removal of any panel or the replacement of any component.

All components are accessible by the removal of the swing spout, front cupola cover, rear cupola cover and the cupola.

Disconnect the swing spout nut from the swing spout base fitting. Remove swing spout.

Remove the four #8-32 screws, two on the front and rear, securing front and rear cupola covers to the cupola.

Slip cupola off of the component bracket.

Contents

Circuit Breaker	14
Contactor	15
Control Thermostat	17
Fuse and Fuse Holder	18
Limit Thermostat	19
Liquid Level Board and Level Probe	20
ON/OFF Switch	22
Pump	23
Relay	24
Selector Switch (Half Batch)	26
Solenoid	27
Start Switch (Brew)	29
Tank Heater(s)	30
Thermal Cut-off	31
Timer (Early Models)	31
Digital Timer (Late Models)	33
Transformer	35
Wiring Diagrams	36 thru 41

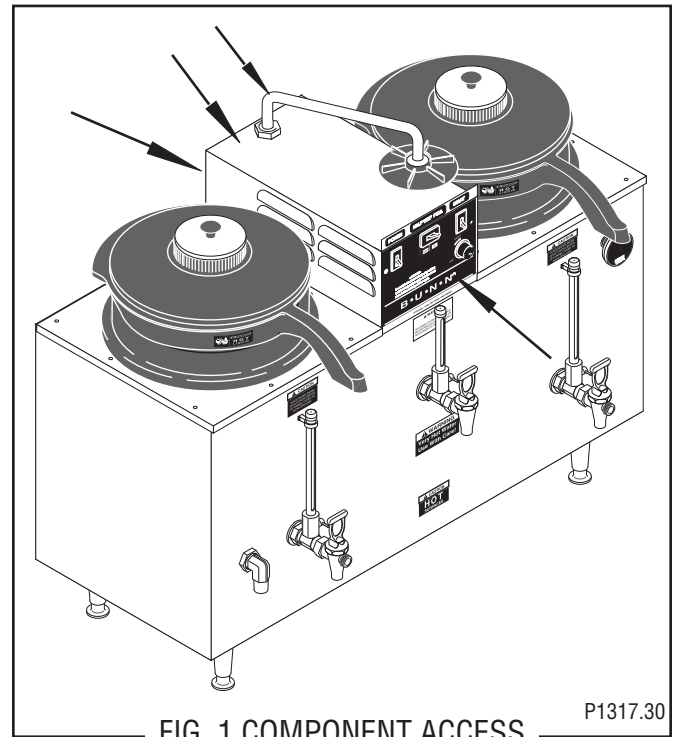

FIG. 1 COMPONENT ACCESS

SERVICE (cont.)

CIRCUIT BREAKER (120/208V and 120/240V Three Wire Models and 440V Four Wire Models)

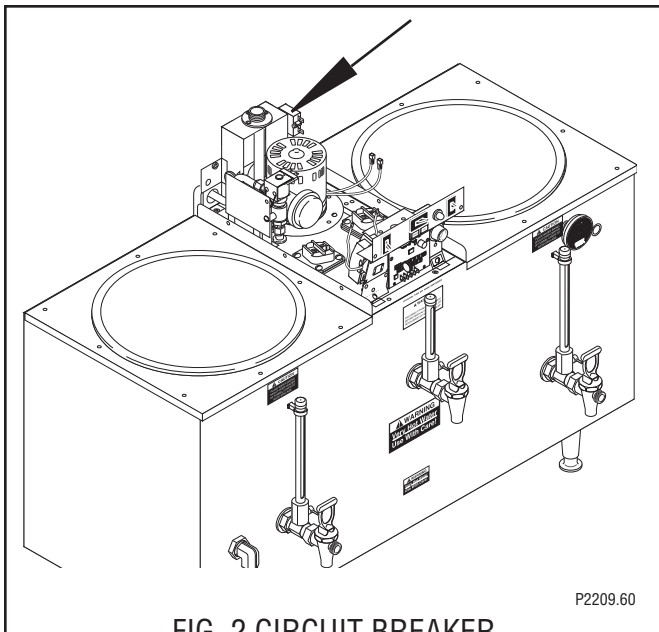

FIG. 2 CIRCUIT BREAKER

Location:

The circuit breaker is located on the right rear of the component bracket.

Test Procedures:

1. Disconnect the brewer from the power source.
2. Disconnect the black wire from the main harness from the circuit breaker and the white wire on the pump assembly. With a voltmeter, check the voltage across the black wire and the white wire. Connect the brewer to the power source. The indication must be:
 - a) 120 volts ac for three wire 120/208 volt and 120/240 volt models.
 - b) 208 or 240 volts ac for four wire 440 volt models.
3. Disconnect the brewer from the power source.

If voltage is present as described, reconnect the white wire to the pump assembly and proceed to #4. If voltage is not present as described, refer to the **Wiring Diagrams** and check the brewer wiring harness.

4. With the black wire removed, remove the other black wire from the circuit breaker.
5. Check for continuity across the terminals on the circuit breaker.

If continuity is present as described the circuit breaker is operating properly.

If continuity is not present as described, press the reset button and repeat step 5, if continuity is not present as described, replace the circuit breaker.

Removal and Replacement:

1. Remove wires from the circuit breaker.
2. Remove the nut securing the circuit breaker to the component bracket.
3. Remove circuit breaker and discard.
4. Install new circuit breaker on component bracket and secure with nut.
5. Refer to Fig. 3 and reconnect the wires.

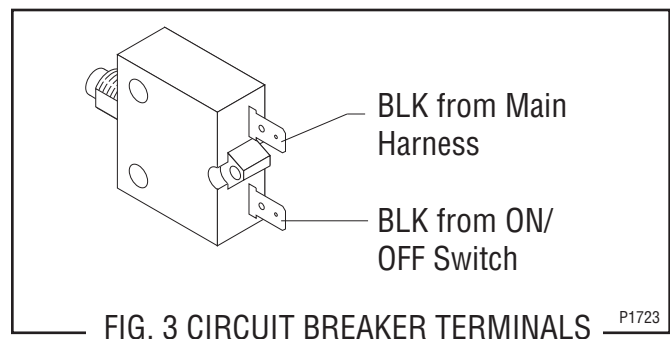

FIG. 3 CIRCUIT BREAKER TERMINALS

SERVICE (cont.)

CONTACTOR

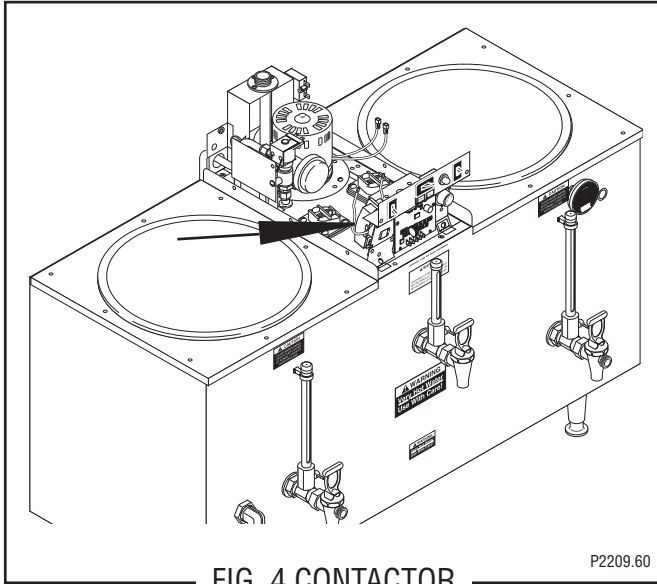

FIG. 4 CONTACTOR

Location:

The contactor is located on the left front of the component bracket

Test Procedures:

1. Disconnect the brewer from the power source.
- 2A. 120/208V, 120/240V, 380V THREE WIRE MODELS, 380V and 440V FOUR WIRE MODELS
Disconnect the black wire from the contactor coil to the limit thermostat and black wire from the white wire on the main harness.
- 2B. 208V or 240V TWO WIRE MODELS (Prior to # U300004095), 208V and 240V THREE WIRE MODELS
Disconnect the black wire from the contactor coil to the limit thermostat and black wire from the red wire on the main harness.
- 2C. 230V MODELS (S/N U300004095 - UP)
Disconnect the red wire from contactor coil to the limit thermostat and the black wire from the main harness.
3. Connect the brewer to the power source.
4. Check the voltage across the coil wire and the wire from the the main harness.The indication must be:

- a) 120 volts ac for three wire 120/208, 120/240 volt and 380 volt models.
- b) 230 volts ac for two wire 230 volt models.
- c) 208 or 240 volts ac for two wire 208 or 240 volt models.
- d) 220 or 254 volts ac for four wire 280 or 440 volt models.

5. Disconnect the brewer from the power source.

If voltage is present as described, proceed to #6.
If voltage is not present as described refer to the **Wiring Diagrams** and check the brewer wiring harness.

6. Check for continuity between the black leads on the contactor coil or the left and right terminals on the contactor coil on 230V models.

If continuity is present as described, reconnect the wires and proceed to #7.

If continuity is not present as described, replace the contactor.

7. On all brewers, with a voltmeter, check the voltage across the upper left terminal and the upper right terminal on the contactor. Connect the brewer to the power source. The indication must be:
 - a) 120 volts ac for three wire 120/208, 120/240 volt and 380 volt models.
 - b) 230 volts ac for two wire 230 volt models.
 - c) 208 or 240 volts ac for two wire 208 or 240 volt models.
 - d) 220 or 254 volts ac for four wire 280 or 440 volt models.

8. Disconnect the brewer from the power source.

If voltage is present as described, proceed to #9.
If voltage is not present as described, refer to the **Wiring Diagrams** and check the brewer wiring harness.

SERVICE (cont.)

CONTACTOR (cont.)

- 9. Check for continuity across the terminals on the left side of the contactor by manually closing the contacts. Continuity must not present when the contact is released.
- 10. Check for continuity across the terminals on the right side of the contactor by manually closing the contacts. Continuity must not be present when the contact is released.

If continuity is present as described, the contactor is operating properly.

If continuity is not present as described, replace the contactor.

Removal and Replacement:

- 1. Disconnect all the wires from the contactor.
- 2. Remove the two #8-32 screws securing the contactor to the contactor mounting bracket, remove contactor and protective shield. Discard contactor.
- 3. Install new contactor with shield between mounting bracket and contactor and secure with two #8-32 screws
- 4. Refer to Fig. 5 and reconnect the wires.

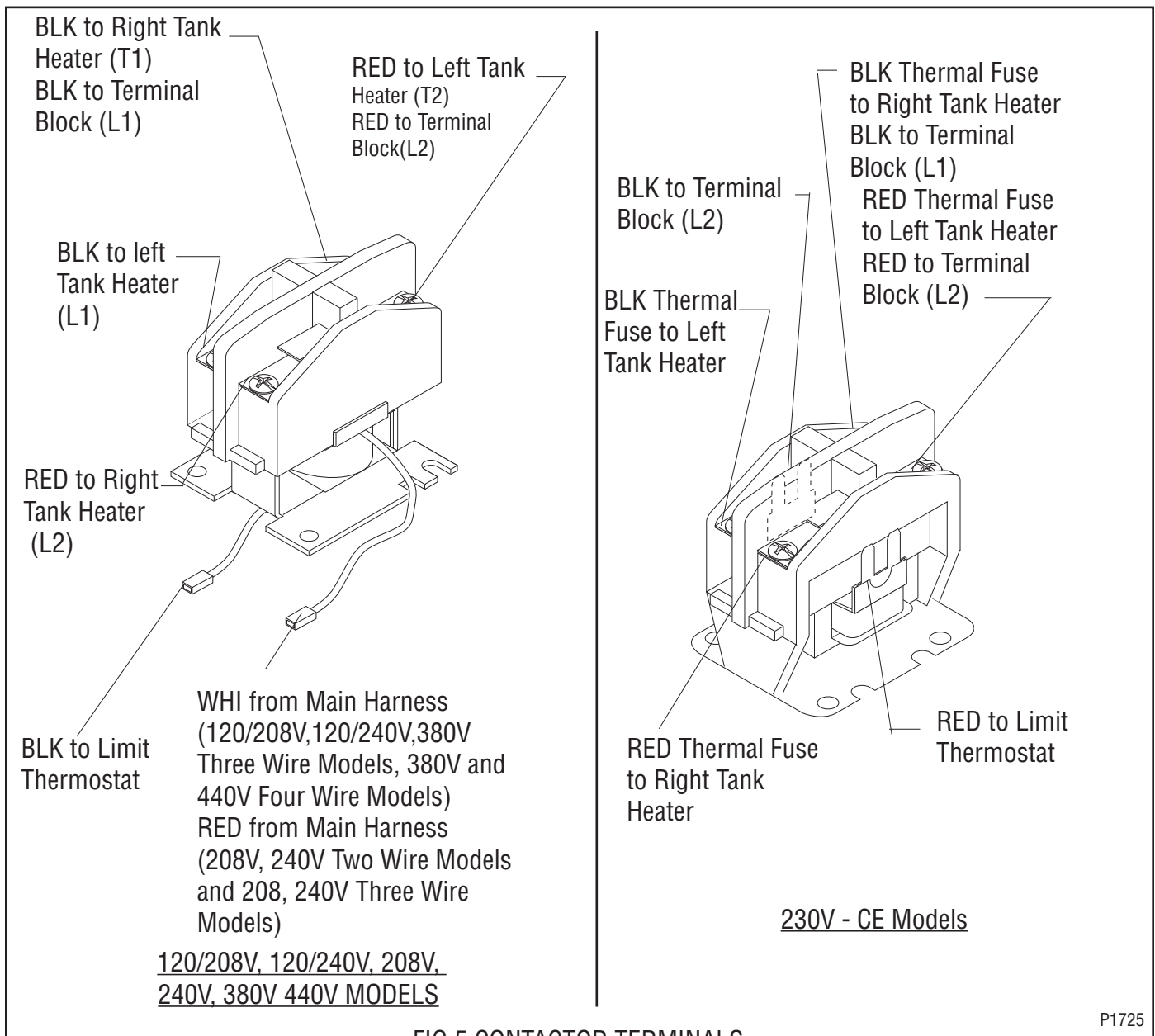
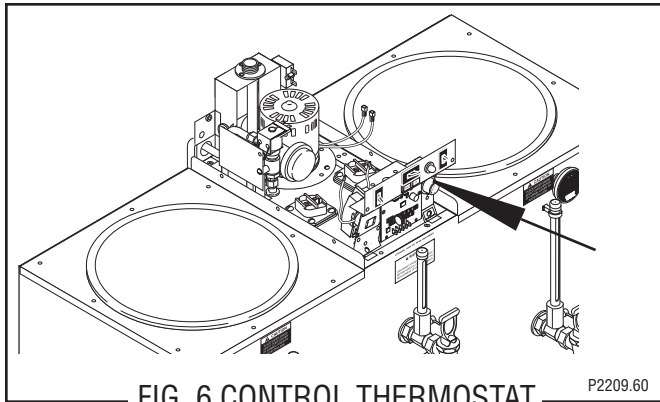

FIG.5 CONTACTOR TERMINALS

P1725

SERVICE (cont.)
CONTROL THERMOSTAT



Location:

___ The control thermostat is mounted on the right front of the component bracket.

Test Procedures:

1. Disconnect the brewer from the power source.
2. Locate the thermostat and the voltage check points.
3. Connect the brewer to the power source.

Model	Check Voltage Across	Voltage
120/208V & 120 240V - 3 wire w/ ground single phase	Black wire on thermostat from main harness to white wire in terminal block.	120V
230V - 2 wire w/ ground single phase	Red wire on thermostat from main harness to black wire in terminal block.	230V
208V or 240V - 2 wire w/ground single phase	Black wire on thermostat from main harness to red wire in the terminal block.	208V or 240V
280V or 440V - 4 wire w/ground 3 phase	Black wire on thermostat from main harness to white wire in terminal block.	220V or 254V
380V - 3 wire w/ ground 3 phase w/ stepdown transformer	Black wire on thermostat from main harness to white wire on step down trans- former.	120V

4. Disconnect the brewer from the power source. If voltage is present as described, proceed to #5. If voltage is not present as described, refer to the **Wiring Diagrams** and check the brewer wiring harness.

5. Disconnect the black wires from the control thermostat.
6. Check for continuity across the terminals on the control thermostat with the control thermostat in the "ON" position (fully clockwise), continuity must

not be present when the thermostat is in the "OFF" position (fully counterclockwise).

If continuity is present as described, the control thermostat is operating properly.

If continuity is not present as described, replace the control thermostat.

Removal and Replacement:

1. Disconnect the wires from the control thermostat.
2. Remove the thermostat capillary bulb by firmly pulling up on the capillary at the component bracket. This will disengage the grommet from the component bracket.
3. Remove the #8-32 screw securing the control thermostat and mounting bracket to the component bracket. Remove control thermostat and bracket as an assembly.
4. Remove knob from control thermostat.
5. Remove the two #6-32 screws securing the control thermostat to the thermostat mounting bracket. Remove and discard thermostat.
6. Install new control thermostat on thermostat mounting bracket and secure with two #6-32 screw.
7. Install knob on thermostat.
8. Install thermostat and mounting bracket on the component bracket and secure with one #8-32 screw.
9. Carefully bend the capillary tube so that the tube and bulb inside the brewer are in the vertical position.

NOTE: The capillary tube must be clear of any electrical termination and not kinked.

10. Refer to Fig. 7 and reconnect the wires.
11. Adjust the control thermostat as required.

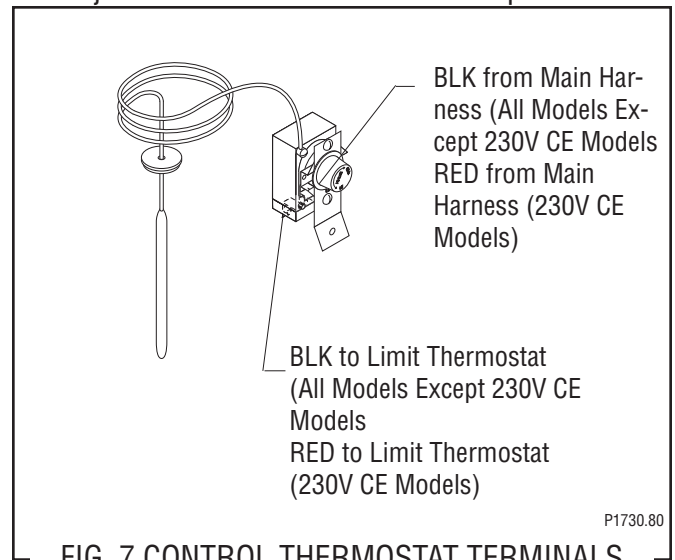

SERVICE (cont.)

FUSE AND FUSE HOLDER (208V, 240V, 230V Two Wire Models and 380V Three Wire Models)

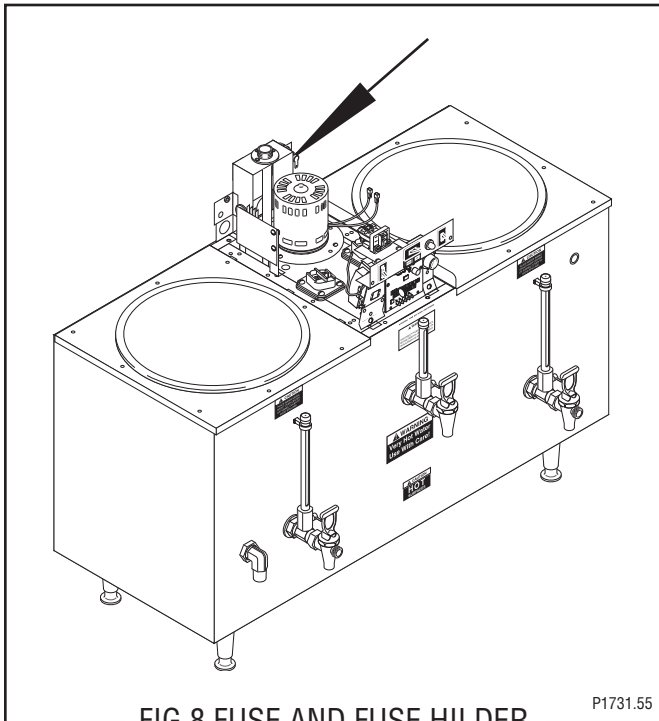

FIG.8 FUSE AND FUSE HILDER

Location:

The fuse and fuse holder are located on the right rear of the component bracket.

Test Procedures:

1. Disconnect the brewer from the power source.
2. Remove the cap and fuse from the fuse holder.
3. Remove fuse from the cap.
4. Check for continuity through the fuse.

If continuity is present as described, reinstall the fuse, the fuse is operating properly.

If continuity is not present as described replace the fuse.

Removal and Replacement:

Fuse:

1. Remove the cap from the fuse holder.
2. Remove fuse from the fuse holder, inspect, if blown discard.
3. Install new 5 amp fuse in the fuse holder.
4. Reinstall fuse holder cap.

Fuse Holder:

1. Disconnect the wires from the rear of the fuse holder.
2. Remove the nut securing the fuse holder to the component bracket.
3. Push fuse holder through the hole in the component bracket.
4. Install new fuse holder and fuse through the hole in the component bracket and secure with nut.
5. Refer to Fig. 9 and reconnect the wires.

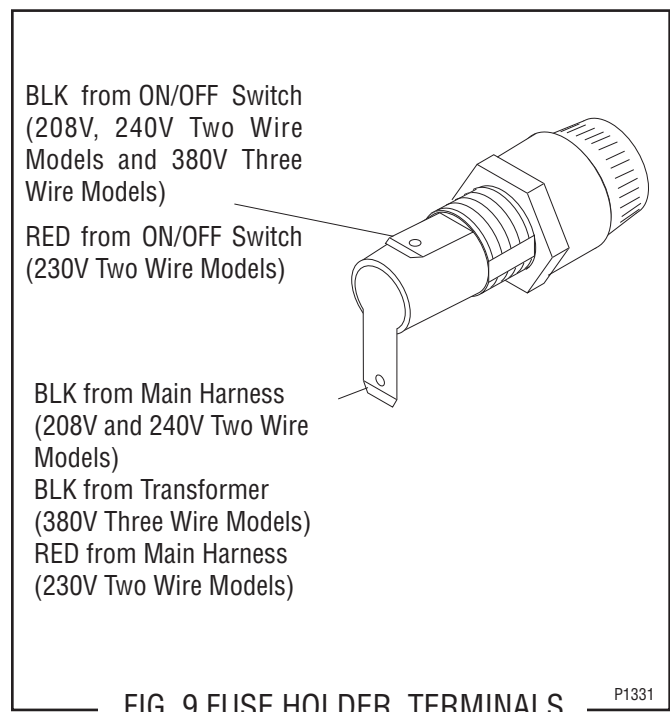

FIG. 9 FUSE HOLDER TERMINALS

SERVICE (cont.)

LIMIT THERMOSTAT

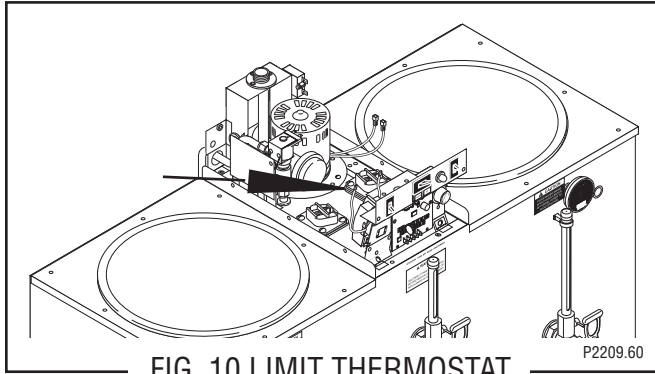

FIG. 10 LIMIT THERMOSTAT

Location:

___ The limit thermostat is located on the center front of the component bracket behind the timer mounting bracket.

Test Procedures:

1. Disconnect the brewer from the power source.
2. Disconnect the black wires or the red wires from the limit thermostat.
3. With an ohmmeter, check for continuity across the limit thermostat terminals.

If continuity is present as described, the limit thermostat is operating properly.

If continuity is not present as described, replace the limit thermostat.

Removal and Replacement:

1. Remove the wires from the limit thermostat terminals.
2. Carefully slide the limit thermostat out from under the retaining clip and remove the limit thermostat.
3. Carefully slide the new limit thermostat into the retaining clip.
4. Refer to Fig. 11 and reconnect the wires.

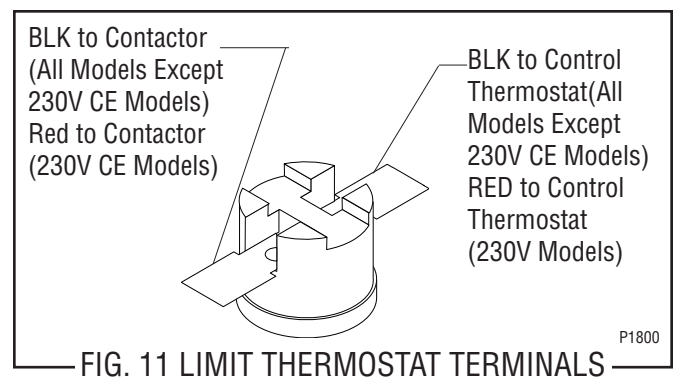

FIG. 11 LIMIT THERMOSTAT TERMINALS

SERVICE (cont.)

LIQUID LEVEL BOARD AND LEVEL PROBE

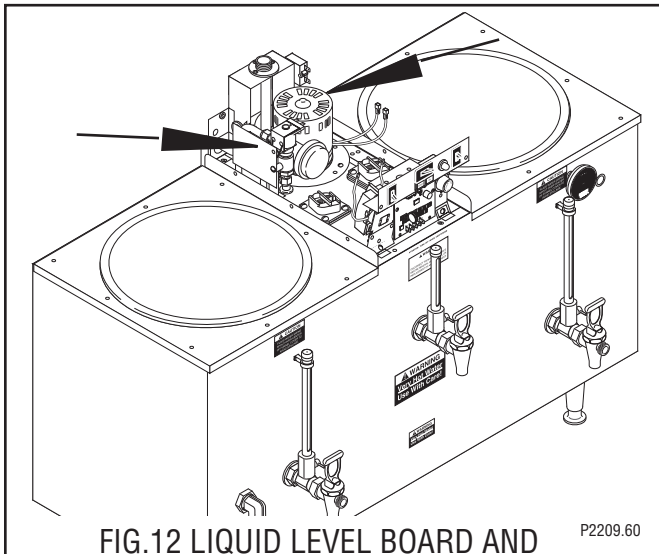

FIG.12 LIQUID LEVEL BOARD AND
LEVEL PROBE

Location:

The liquid level board is located on the left rear of the component bracket. The level probe is located on the right rear of the component bracket.

Test Procedures:

1. Disconnect the brewer from the power source.
2. Disconnect the blue wire (T1) and the pink wire (T4).
3. Check the voltage across terminals (T2) and (T3) with the ON/OFF switch in the "ON" position. The indication must be:
 - a) 120 volts ac for 120/208 volt, 120/240 volt and 380 volt models.
 - b) 208 volts ac or 240 volts ac for two wire 208 volt or 240 volt models.
 - d) 230 volts ac for two wire 230 volt models.
 - e) 220 volts ac or 440 volts ac for four wire 280 volt or 440 volt machines.
4. Disconnect the brewer from the power source. If voltage is present as described, proceed to #5. If voltage is not present as described, refer to **Wiring Diagrams** and check the brewer wiring harness.
5. Reconnect the blue wire to T1 on the liquid level board.
6. Carefully connect a piece of insulated jumper wire to terminal 4. Keep the other end of this wire away from any metal surface of the brewer.

7. Touching the free end of the jumper to the brewer's frame simulates a "FULL" condition, preventing jumper from touching the brewer's frame simulates "NEED WATER" condition. Connect the brewer to the power source, simulate the conditions in the chart below while measuring the voltage between T1 and T3 On the liquid level board. Repeat these several times. There is an approximate five second delay for output to stabilize.

Model	Voltage - Jumper Not Touching Frame	Voltage - Jumper Touching Frame
120/208V & 120/240V - 3 wire w/ground single phase	120V	0
230V - 2 wire w/ground single phase	230V	0
208V or 240V - 2 wire wground single phase	208V or 240V	0 0
280V or 440V - 4 wire w/ground 3 phase	220V or 254V	0 0
380V - 3 wire w/ground 3 phase w/ stepdown trans- former	120V	0

8. Disconnect the brewer from the power source and remove the jumper wire from terminal 4. If voltage is present as described, liquid level board is operating properly, proceed to #9. If voltage is not present as described, replace the liquid level board.

SERVICE (cont.)

LIQUID LEVEL BOARD AND LEVEL PROBE (cont.)

9. Reconnect the pink wire to terminal 4.
10. Remove the two #8-32 screws securing the level probe to the component bracket.
11. Gently pull the probe out of the component bracket and inspect for corrosion. Replace if necessary.
12. Place the probe so that neither end is in contact with any metal surface of the brewer.
13. Connect the brewer to the power source. Check the voltage across terminals 1 and 3, refer to chart below. There is an approximate delay of five seconds for output to stabilize.

<u>Model</u>	<u>Voltage - Jumper Not Touching Frame</u>	<u>Voltage - Jumper Touching Frame</u>
120/208V & 120/240V - 3 wire w/ground single phase	120V	0
230V - 2 wire w/ground single phase	230V	0
208V or 240V - 2 wire w/ground single phase	208V or 240V	0
280V or 440V - 4 wire w/ground 3 phase	220V or 254V	0
380V - 3 wire w/ground 3 phase w/ stepdown transformer	120V	0

14. Disconnect the brewer from the power source.

If voltage is present as described, reinstall the level probe, the liquid level board and level probe are operating properly.

If voltage is not present as described, check the pink wire on the level probe from liquid level board terminal 4.

Removal and Replacement:

1. Remove all wires from the liquid level board.
2. Remove the #10-32 screw and flat washer securing the protective shield to the component bracket.
3. Remove the #10-32 screw and internal tooth lockwasher securing the liquid level board to the component bracket.
4. Remove liquid level board and discard.
5. Install new liquid level board on component bracket and secure with a #10-32 screw and internal tooth lockwasher.
6. Install protective shield and secure with #10-32 screw and flat washer.
7. Refer to Fig. 13 and reconnect the wires.

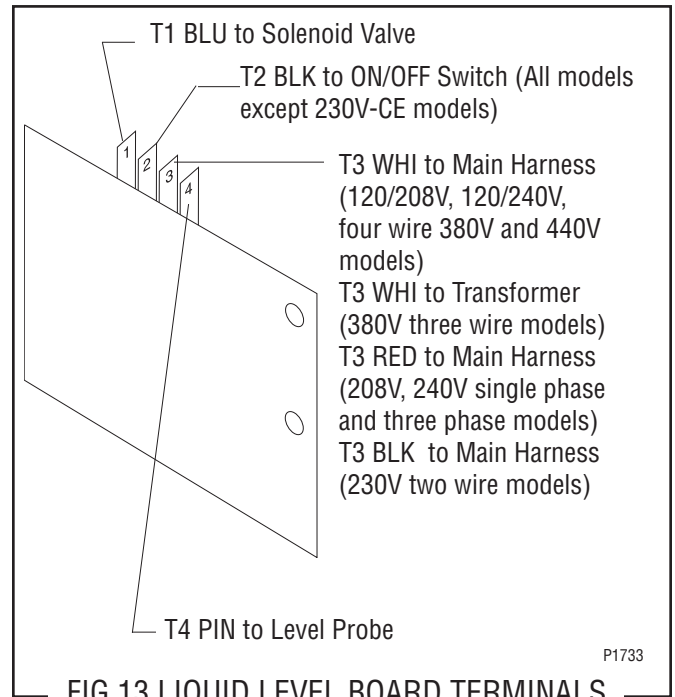

FIG.13 LIQUID LEVEL BOARD TERMINALS

SERVICE (cont.)
ON/OFF SWITCH

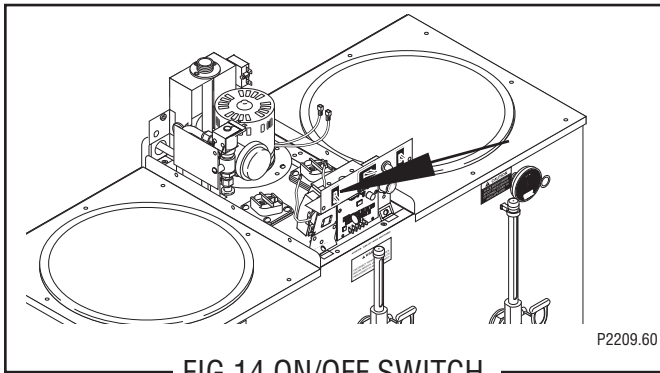

FIG.14 ON/OFF SWITCH

Location:

The ON/OFF switch is located on the left side of the switch mounting bracket. The switch mounting bracket is mounted on the front of the component bracket.

Test Procedures:

1. Disconnect the brewer from the power source.
2. a) 120/208V, 120/240V, 208V and 240V Models
Remove the black wire on the ON/OFF switch from the fuse holder or circuit breaker and the red wire on the power indicator light.
- b) 380V and 440V Models - Remove the black wire on the ON/OFF switch from the fuse holder or circuit breaker and the white wire from the power indicator light.
- c) 230V - CE Models - Remove the red wire on the ON/OFF switch from the fuse holder and the black wire on the power indicator light.
3. Connect the brewer to the power source. With a voltmeter, check the voltage across the removed wires. The indication must be:
 - a) 120 volts ac for 120/208 volt, 120/240 volt and 380 volt models.
 - b) 208 volts ac for two or three wire 208 volt models.
 - c) 240 volts ac for two wire 240 volt models prior to #U300004095 and three wire 240 volt models.
 - d) 230 volts ac for two wire 230 volt models #U300004095 and up).
 - e) 208 or 240 volts ac for four wire 440 volt models.
4. Disconnect the brewer from the power source.

If voltage is present as described, reconnect the wires and proceed to #5

If voltage is not present as described, refer to the **Wiring Diagrams** and check the brewer wiring harness.

5. Disconnect the wires on the ON/OFF switch.
6. a) 120/208V, 120/240V, 208V, 240V, 380V and 440V Models - Check for continuity across the terminals on the rear of the switch with the switch in the "ON" (upper) position. Continuity must not be present when the switch is in the "OFF" (lower) position.
- b) 230V - CE Models - Check for continuity across the center terminal (2) and the lower terminal (1) when the switch is in the "ON" (upper) position. Continuity must not present when the switch is in "OFF" (lower) position.

If continuity is present as described, the switch is operating properly.

If continuity is not present as described, replace the switch.

Removal and Replacement:

1. Remove the wires from the switch terminals.
2. Compress the clips on the back side of the switch mounting bracket and gently push the through the opening.
3. Push the new switch into the opening and spread the clips to hold switch in the mounting bracket.

NOTE: ON 230V - CE models terminal (3) must be on the top.

4. Refer to Fig. 15 and reconnect the wires.

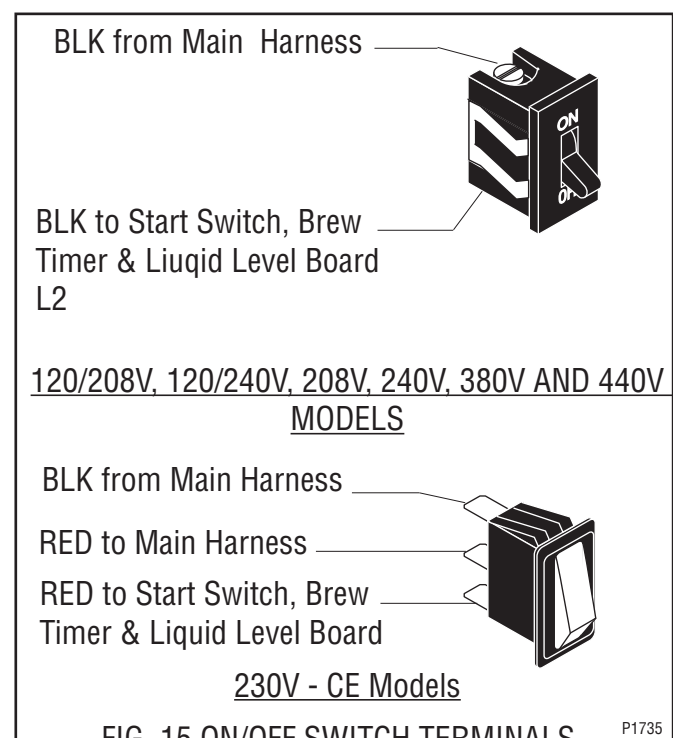

FIG. 15 ON/OFF SWITCH TERMINALS

SERVICE (cont.) PUMP ASSEMBLY

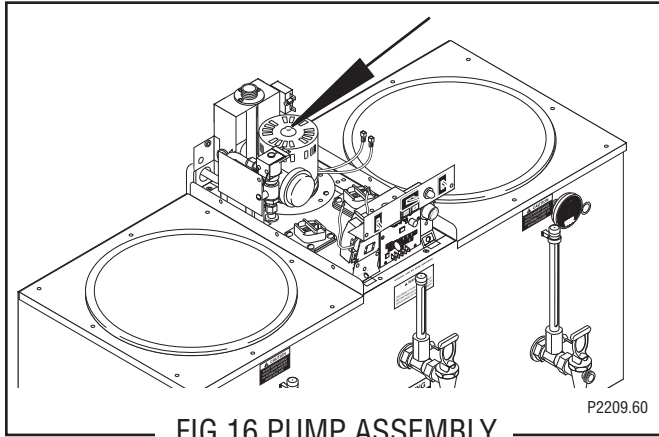

FIG.16 PUMP ASSEMBLY

Location:

The pump is located on the center rear of the component bracket.

Test Procedures:

1. Disconnect the brewer from the power source.
2. Disconnect the black wire from the black lead on the pump and the white wire from the black lead on the pump.
3. With a voltmeter, check the voltage across the black wire and the white wire. Connect the brewer to the power source. The indication must be:
 - a) 120 volts ac for three wire 120/208 volt, 120/240 volt and 380 volt models).
 - b) 208 volts ac for two or three wire 208 volt models.
 - c) 240 volts ac for two or three wire 240 volt models.
 - d) 230 volts ac for two wire 230 volt models.
 - e) 208 or 240 volts ac for four wire 440 volt models
4. Disconnect the brewer from the power source.

If voltage is present as described, reconnect the wires to the pump. Install swing spout and position over the reservoir. Place the ON/OFF in the "ON" (upper) position and push the start switch and release. If pump does not run, replace the pump.

If voltage is not present as described, refer to the **Wiring Diagrams** and check the brewer wiring harness.

Removal and Replacement (Refer to Fig. 17):

1. Disconnect the wires from the pump assembly.
2. Loosen the #8-32 screw (2) securing the clamp (3) on the fill tube (1) and slide the clamp (3) up the fill tube (1).
3. Disengage the fill tube (1) from the pump assembly (4).
4. Remove the four #8-32 screws (6) securing the pump assembly (4) to the component bracket (7).
5. Remove pump assembly (4).
6. Remove pump gasket (5) and inspect, replace if necessary.
7. Position gasket (5) on component bracket (7).
8. Install new pump assembly (4) on component bracket (7) and secure with four #8-32 screws (6).
9. Install fill tube (1) on pump assembly (4).
10. Slide clamp (3) down into position on the fill tube (1) and tighten screw (2).
11. Refer to Fig. 17 and reconnect the wires.

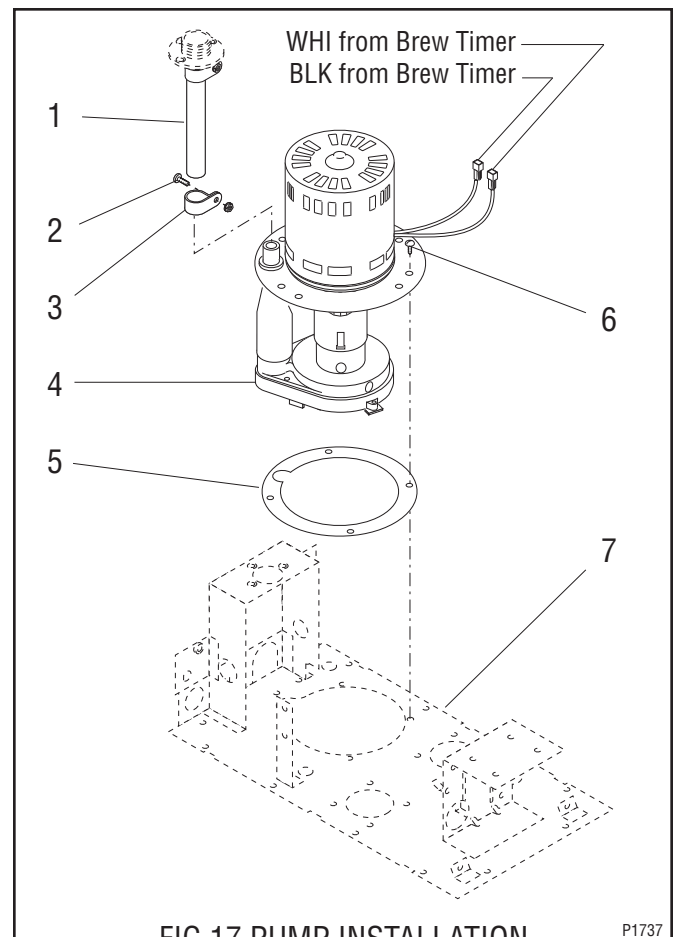

FIG.17 PUMP INSTALLATION

P1737

SERVICE (cont.)

RELAY (BREWERS W/BREW LOCKOUT)

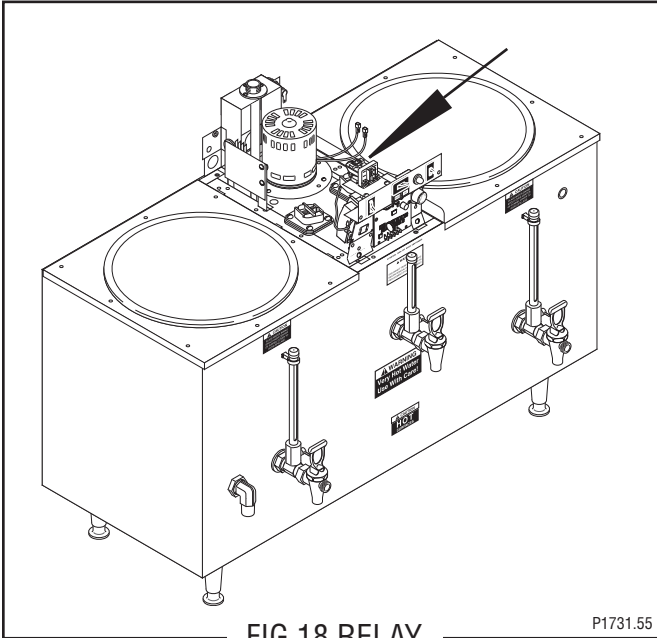

FIG.18 RELAY

P1731.55

Location:

The relay is located on the front part of the component bracket, mounted on the top of the timer bracket.

Test Procedures:

All Models Except 230V - CE Models

1. Disconnect the brewer from the power source.
2. Disconnect the wires from relay terminals "A" & "B". Check for continuity between terminals "A" & "B".

If continuity is present as described, reconnect the wires to terminals "A" & "B" and proceed to #3.

If continuity is not present as described replace the relay.

3. Disconnect the wires from relay terminals 2 & 7.
4. Check for continuity across terminals 2 & 7.

If continuity is present as described, reconnect the wires to terminals 2 & 7 and proceed to # 5.

If continuity is not present as described, replace the relay.

5. Disconnect the wires from relay terminals 5 & 7.
6. Check for continuity across terminals 5 & 7 by manually closing relay contact. Continuity must not be present when contact is released.

If continuity is present as described, reconnect the wires, the relay is operating properly.

If continuity is not present as described, replace the relay.

230V - CE Models

1. Disconnect the brewer from the power source.
2. Disconnect the black wire from relay terminal "A" and the red wire from relay terminal "B". Check the voltage across the black and red wire with a voltmeter. Connect the brewer to the power source. The indication must be 230 volts ac.

If voltage is present as described, proceed to #3.

If voltage is not present as described, refer to the **Wiring Diagrams** and check the brewer wiring harness.

3. Disconnect the brewer from the power source.
4. Check for continuity across relay terminals "A" & "B"

If continuity is present as described, reconnect the wires to terminals "A" & "B" and proceed to #5.

If continuity is not present as described, replace the relay.

5. With the thermostat in the "ON" position and the relay engaged disconnect the brewer from the power source.
6. Disconnect the blue wires from relay terminals 1 and 7. Check for continuity across terminals 1 and 7.

If continuity is present as described, proceed to #7

If continuity is not present as described, replace the relay.

7. Turn the thermostat to the "OFF" position, connect the brewer to the power source and turn the thermostat back to the "ON" position. Continuity should not be present across terminals 1 & 7.

If continuity is not present as described, the relay is operating properly.

If continuity is present as described, replace the relay.

SERVICE (cont.) RELAY (BREWERS W/BREW LOCKOUT)

Removal and Replacement:

1. Disconnect the wires from the relay.
2. For 120/208V, 120/240V, 208V, 380V, 440V and 240V models prior to #U300004095 remove the #6-32 screw securing the relay to the relay mounting bracket. For 230V models #U300004095 and up, remove the two screws securing the relay to the relay mounting bracket.
3. Remove relay and discard.
4. For 120/208V,120/240V, 208V, 380V, 440V and 240V models prior to #U300004095, install new relay on relay mounting bracket and secure with a #6-32 screw. For 230V models #U300004095 and up, install new relay on relay mounting bracket and secure with two #6-32 screws.
5. Refer to Fig. 19 and reconnect the wires.

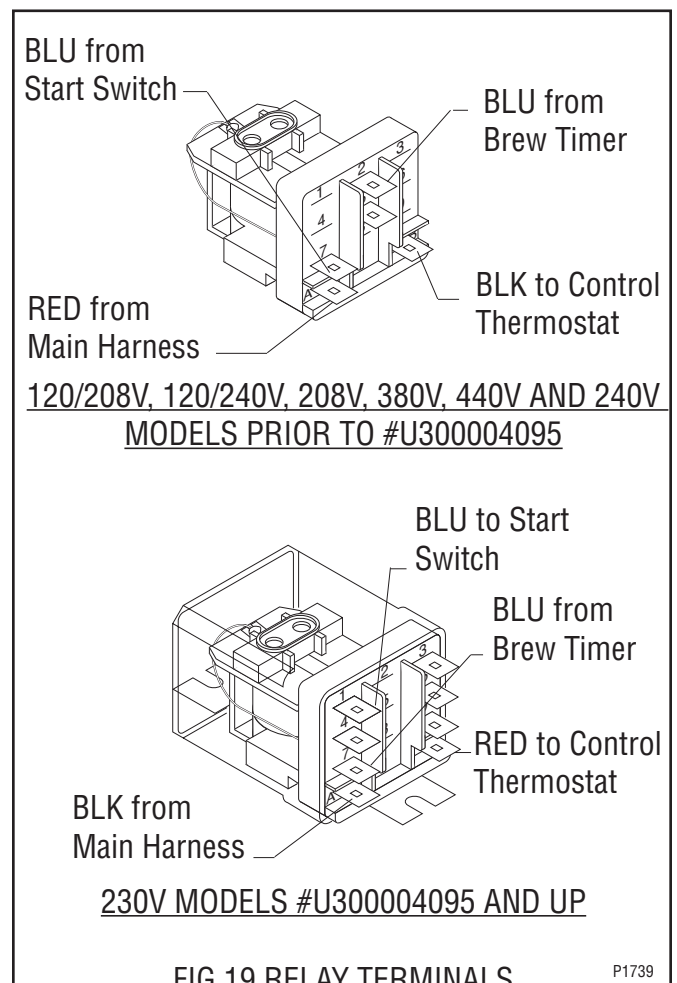

SERVICE (cont.)

SELECTOR SWITCH (HALF BATCH OPTION)

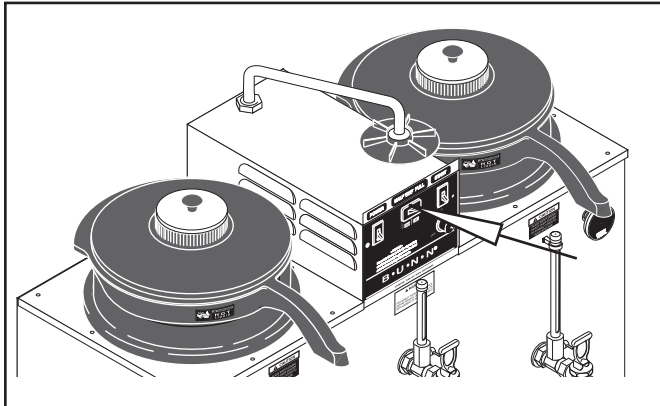

FIG. 20 SELECTOR SWITCH (HALF BATCH)

Location:

The selector switch is located in the upper center of the switch mounting panel.

Test Procedures:

1. Disconnect the brewer from the power source.
2. Disconnect the wires from the switch terminals.
3. Check for continuity across the switch terminals with the switch in the "CLOSED" (left - half) position. Continuity must not present when the switch is in the "OPEN" (right - full) position.

If continuity is present as described, the switch is operating properly.

If continuity is not present as described, replace the switch.

Removal and Replacement:

1. Remove the wires from the switch terminals.
2. Compress the clips on the back side of the switch mounting bracket and gently push the through the opening.
3. Push the new switch into the opening and spread the clips to hold switch in the mounting bracket.
4. Refer to Fig. 21 and reconnect the wires.

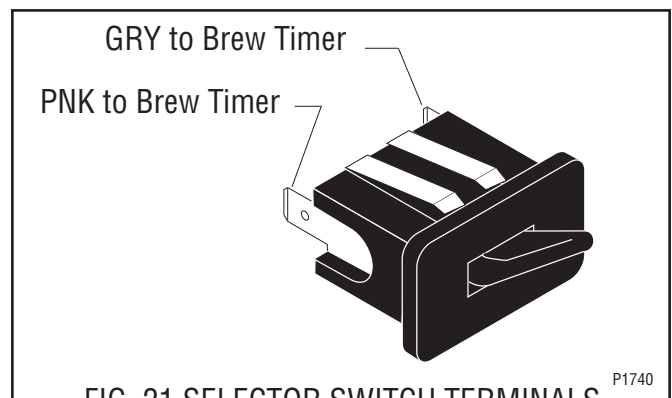
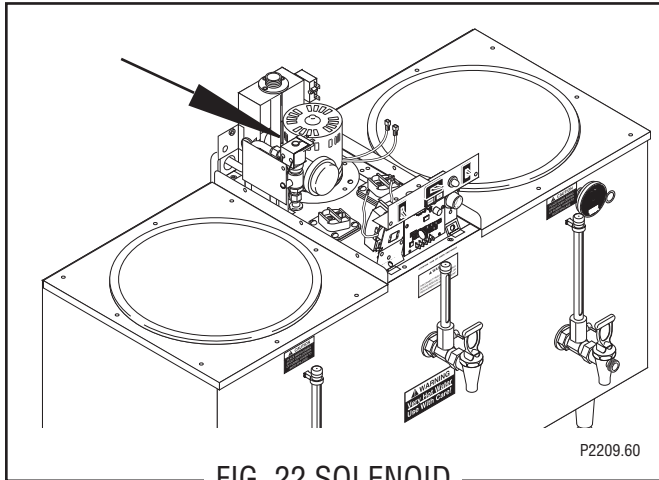

FIG. 21 SELECTOR SWITCH TERMINALS

SERVICE (cont.)

SOLENOID



Location:

The solenoid is mounted on the upper left rear of the component bracket.

Test Procedures:

1. Disconnect the dispenser from the power source.
2. A) For 120/208 volt and 120/240 volt three wire, single phase models, 380 volt three wire, three phase models and 380 volt, 440 volt four wire, three phase models, disconnect the black wire from the liquid level board #2 and the white wire on the solenoid. With a voltmeter, check the voltage across the black and the white wire. Connect the brewer to the power source. The indication must be:
 - a) 120 volts ac for 380 volt three wire, three phase models and 208 Or 240 volts ac for four wire three phase 440 volt models.
 - b) 208 volts ac for three wire 120/208 volt models.
 - c) 240 volts ac for three wire 120/240 volt models.B) For 208 volt, 240 volt two wire single phase and 208 volt, 240 volt three wire three phase models, disconnect the black wire from the liquid level board #2 and the red wire from the solenoid. With a voltmeter, check the voltage across the black and red wires. Connect the brewer to the power source. The indication must be:
 - a) 208 volts ac for 208 volt two wire single phase and 208 volt three wire three phase models.
 - b) 240 volts ac for 240 volt two wire single phase and 240 volt three wire three phase models.

C) For 230V - CE two wire single phase models, disconnect the red wire from the liquid level board #2 and the black wire from the solenoid. With a voltmeter, check the voltage across the red wire and the black wire. Connect the brewer to the power source. The indication must be 230 volts ac.

3. Disconnect the dispenser from the power source.

If voltage is present as described, proceed to #4. If voltage is not present as described, refer to the brewer **Wiring Diagrams** and check the wiring harness.

4. Disconnect the blue wire and the white wire, the blue wire and the red wire or blue wire and black wire from the solenoid terminals.
5. Check for continuity across the solenoid valve coil terminals.

If continuity is present as described, reconnect the wires to the solenoid.

If continuity is not present as described, replace the solenoid valve.

6. Check the solenoid valve for coil action. Connect the dispenser to the power source. Listen carefully in the vicinity of the solenoid valve for a "clicking" sound as the coil magnet attracts.

If the sound is heard as described and water will not pass through the solenoid valve, there may be a blockage in the water line before the solenoid valve or, the solenoid valve may require inspection for wear, and removal of waterborne particles.

If the sound is not heard as described, replace the solenoid valve.

Removal and Replacement:

1. Remove the wires from the solenoid valve.
2. Turn off the water supply to the dispenser.
3. Disconnect the water inlet line from the connector on the solenoid valve.
4. Remove the #10-32 screw and the flat washer securing the liquid level board, shield and the solenoid to the component bracket.
5. Remove solenoid, connectors, air chamber and tank inlet tube as an assembly.

SERVICE (cont.)

SOLENOID

6. Remove the tank inlet tube grommet and discard.
7. Install new tank inlet tube grommet.
8. Install new solenoid assembly.
9. Install liquid level board, shield and secure solenoid assembly and shield to the component bracket with a #10-32 screw and flat washer..
10. Install water inlet tube to connector on the solenoid.
11. Turn on the water supply to the brewer.
12. Refer to Fig. 23 and reconnect the wires.

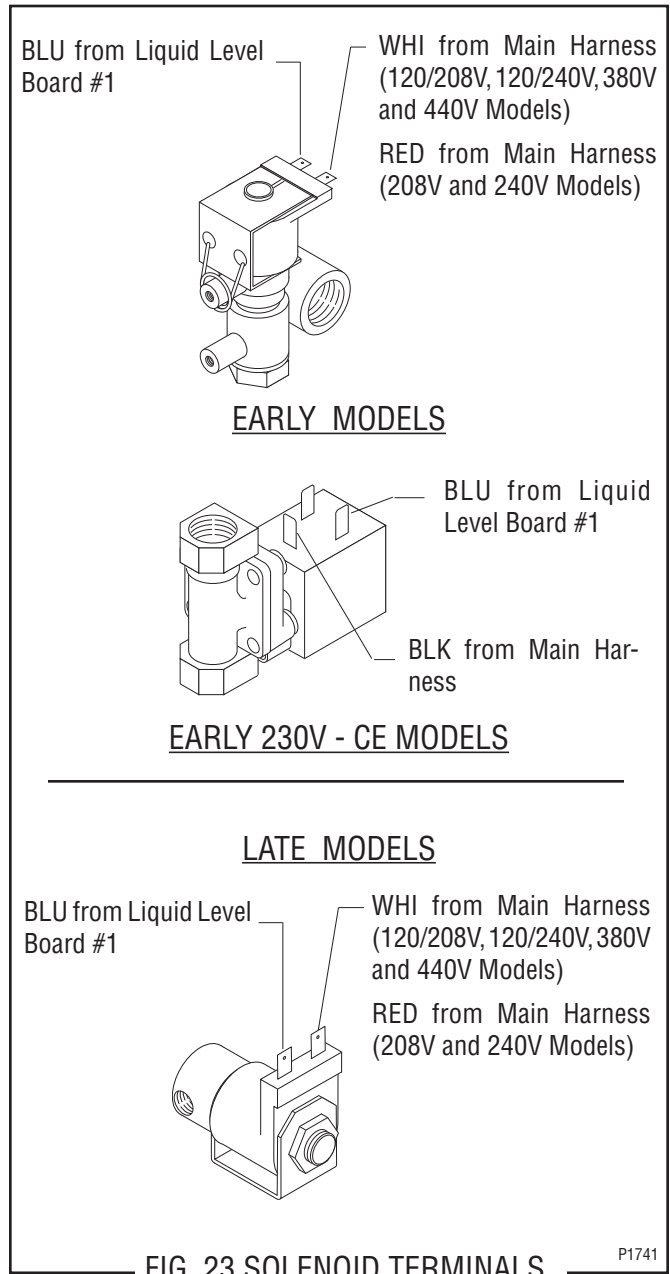

SERVICE (cont.)

START SWITCH (BREW)

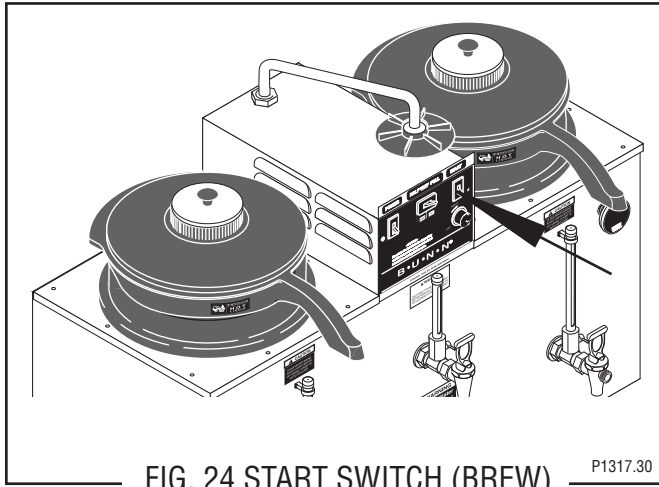

Location:

The brew start switch is located on the upper right side of the brewer component housing.

Test Procedures:

1. Disconnect the brewer from the power source.
2. Remove the wires from the start switch terminals.
3. Check for continuity across the switch terminals when the switch is held in the lower position. Continuity must not be present when the switch is in the upper position.

If continuity is present as described, reconnect the wires the switch is operating properly.

If continuity is not present as described, replace the switch.

Removal and Replacement:

1. Remove the wires from the switch terminals.
2. Compress the clips on the back side of the switch mounting bracket and gently push the through the opening.
3. Push the new switch into the opening and spread the clips to hold switch in the mounting bracket.
4. Refer to Fig. 25 and reconnect the wires.

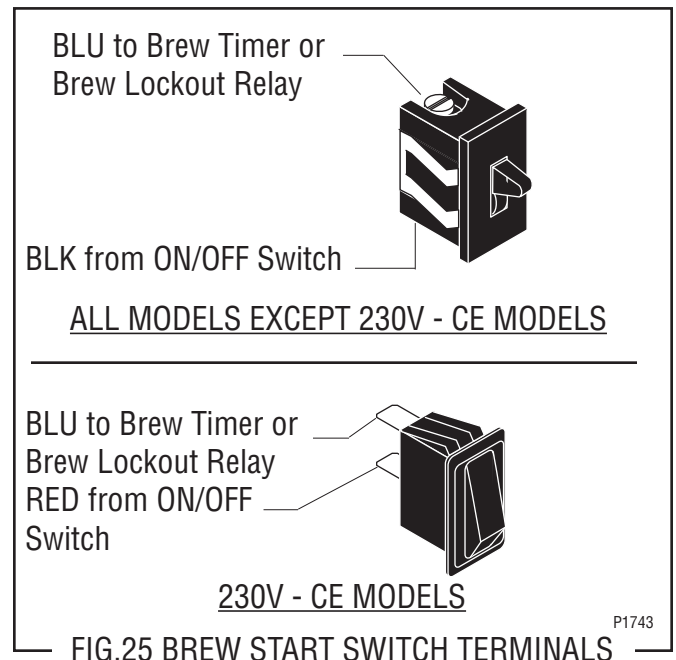

SERVICE (cont.)

TANK HEATERS

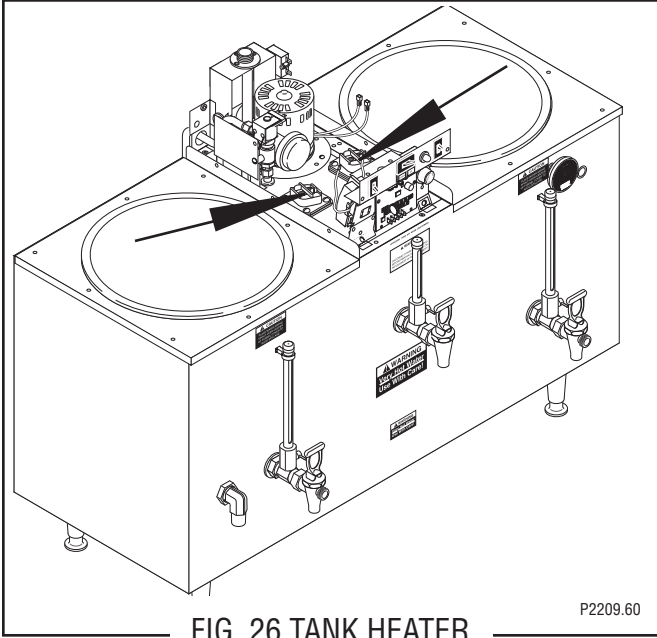

FIG. 26 TANK HEATER

Test Procedures:

1. Disconnect the brewer from the power source.
2. Disconnect the wires from the tank heater.
3. Check for continuity across the tank heater terminals.

If continuity is present as described, proceed to #4. If continuity is not present as described, replace the tank heater.

Removal and Replacement:

1. Remove the wires or thermal fuses from the tank heater.
2. Remove the four #8-32 screws securing the tank heater to the component bracket.
3. Remove tank heater and gasket.
4. Position new tank heater and gasket on the component bracket and secure with four #8-32 screws.
5. Refer to Fig. 27 and reconnect the wires.

Location:

The tank heaters are located on the right center and the left center of the component bracket.

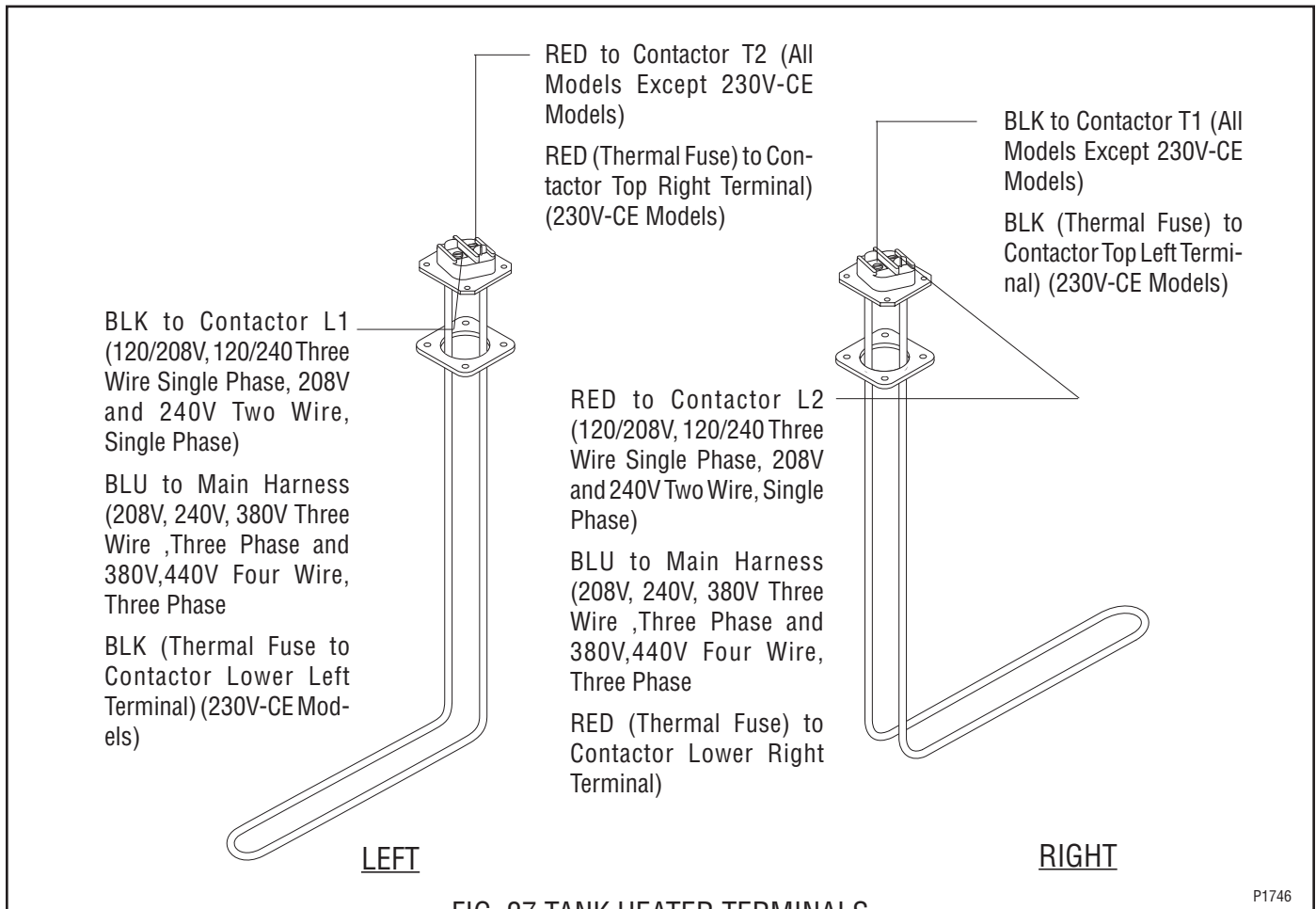
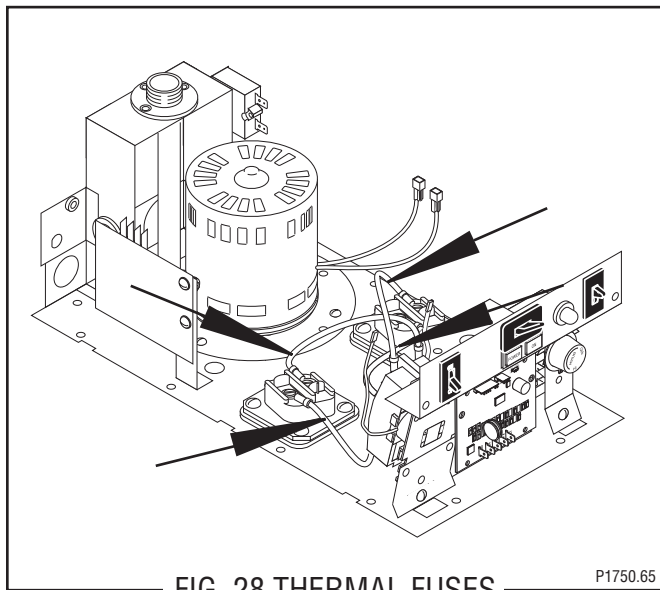

FIG. 27 TANK HEATER TERMINALS

P1746

SERVICE (cont.)

THERMAL FUSES (230V-CE MODELS ONLY)



Location:

The thermal fuses are mounted on the tank heater terminals and the contactor terminals.

Test Procedures:

1. Disconnect the brewer from the power source.
2. Disconnect the thermal fuse from the tank heater terminal and the contactor terminal.
3. Check for continuity across the terminals on the ends of the thermal fuse.

If continuity is present as described, the thermal is operating properly.

If continuity is not present as described, replace the thermal fuse.

Removal and Replacement:

1. Disconnect the thermal fuse from the tank heater terminal and the contactor and discard.
2. Connect the new thermal fuse to the tank heater terminal and the contactor terminal.

TIMER (Early Models)

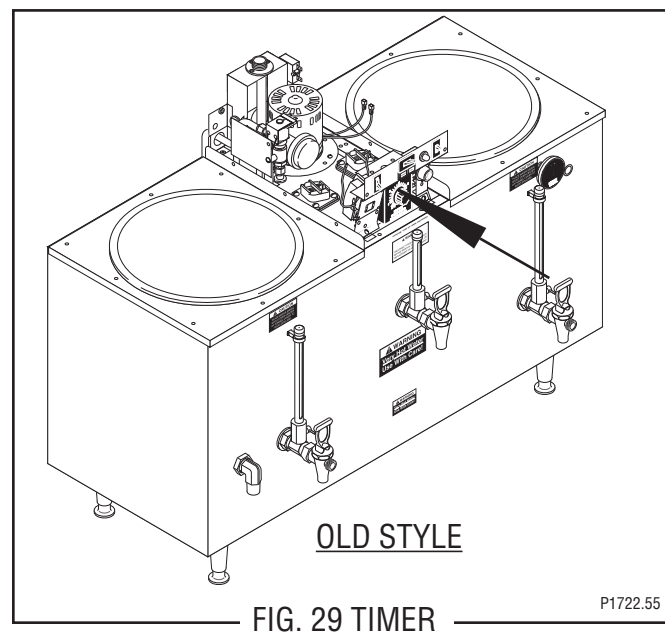

Location:

The timer is located on the front center of the component bracket.

Test Procedures:

1. Disconnect the brewer from the power source.
2. Disconnect the polarized, three pin connector from the brewer main harness and rotate the brew timer dial fully counterclockwise.
3. With a voltmeter, check the voltage across sockets P2 and P3 (white and black wire or red wire) of the female connector on the main wiring harness when the "ON/OFF" switch is in the "ON" (upper) position. Connect the brewer to the power source. The indication must be:
 - a) 120 volts ac for three wire 120/208 volt, 120/240 volt, 380 volt models and 208 or 240 volts ac for four wire 440 volt models.
 - b) 208 volts ac for two and three wire 208 volt models.
 - c) 240 volts ac for two and three wire 240 volt models.
 - d) 230 volts ac for two wire 230 volt CE models.
4. Disconnect the brewer from the power source.

If voltage is present as described, proceed to #5. If voltage is not present as described, refer to the **Wiring Diagrams** and check the brewer wiring harness.

SERVICE (cont.)

TIMER (Early Models)(cont.)

- With a voltmeter, check the voltage across the sockets P1 and P2 (blue and white wires) of the female connector on the main harness when the "ON/OFF" switch is in the "ON" (upper) position and the start switch pressed. Connect the brewer to the power source. The indication must be:
 - 120 volts ac for three wire 120/208 volt, 120/240 volt, 380 volt models and 208 or 240 volt ac for four wire 440 volt models.
 - 208 volts ac for two and three wire 208 volt models.
 - 240 volts ac for two and three wire 240 volt models.
 - 230 volts ac for two wire 230 volt CE models.
- Disconnect the brewer from the power source.
- Reconnect the three pin connector from the main wiring harness to the connector on the timer.

If voltage is present as described, proceed to #8.

If voltage is not present as described, refer to the **Wiring Diagrams** and check the brewer wiring harness.

- Disconnect the black and white wires to the pump.
- With a voltmeter, check the voltage across the black and white wires when the "ON/OFF" switch is in the "ON" (upper) position and the start switch pressed to the start position and released. Connect the brewer to the power source. The indication must be:
 - 120 volts ac for three wire 120/208 volt, 120/240 volt, 380 volt and 208 or 240 volt ac for four wire 440 volt models.
 - 208 volts ac for two and three wire 208 volt models.
 - 240 volts ac for two and three wire 240 volt models.
 - 230 volts ac for two wire 230 volt CE models.

If voltage is present as described, the brew timer is operating properly. Reset the timer dial as required, to obtain the desired brew volume.

If voltage is not present as described, replace the timer.

Removal and Replacement:

- Separate all connectors between the brewer wiring harness and the timer.
- Disconnect the timer leads from the pump leads.
- Remove the two #8-32 screws securing the brew timer to the component bracket and remove timer.
- Install new timer circuit board as described in **Late Model Timer** section on the following pages.
- Refer to Fig. 33 to reconnect the wires.
- Install the Timer Setting Decal, provided with the timer replacement kit, on the back of the front access panel.
- Adjust the timer as required. Refer to **Late Model Timer** section on the following pages.

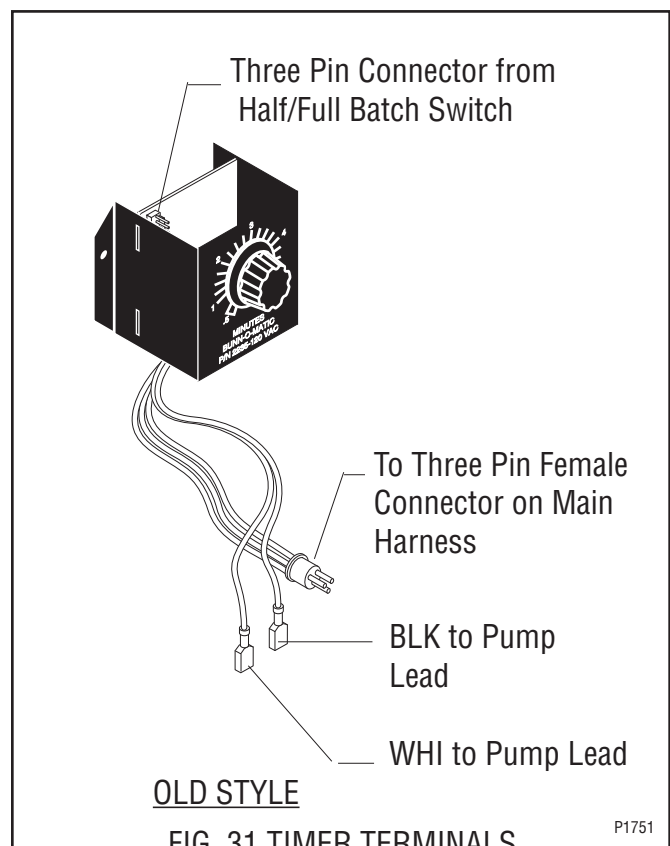

SERVICE (cont.)

DIGITAL TIMER (Late Models)

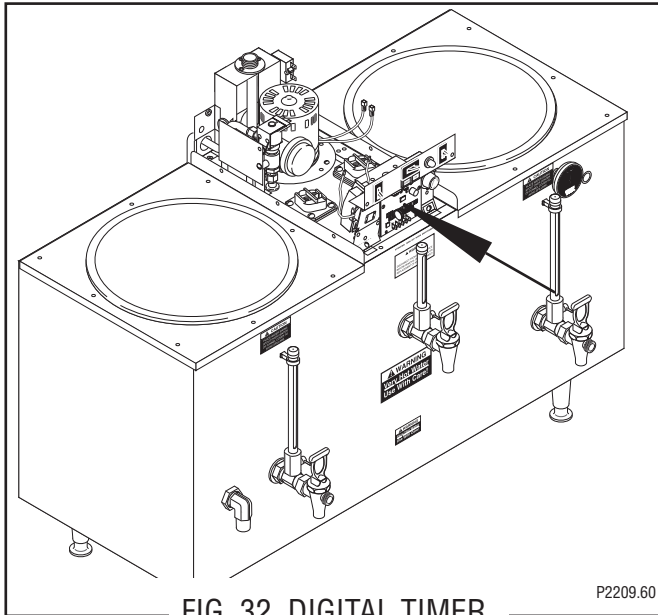

FIG. 32 DIGITAL TIMER

Location:

The timer is located on the front center of the component bracket.

Test Procedure.

NOTE: Do not remove or install wires while timer board is installed. Pressure applied to one side may cause damage to the board.

1. Disconnect the brewer from the power source.
2. Remove the two #8-32 screws securing circuit board to the mounting bracket.
3. Remove circuit board and spacers (as required).
4. With a voltmeter, check the voltage across terminals TL1 and TL2 when the "ON/OFF" switch is in the "ON" position. Connect the brewer to the power source. The indication must be:
 - a) 120 volts ac for three wire 120/208 volt, 120/240 volt and 380 volt models.
 - b) 208 volts ac for two wire 208 volt models.
 - c) 240 volts ac for two wire 240 volt models.
 - d) 230 volts ac for two wire 230 volt CE models.
 - e) 208 or 240 volts ac for four wire 440 volt models.
5. Disconnect the brewer from the power source.

If voltage is present as described, proceed to #6.
If voltage is not present as described, refer to the **Wiring Diagrams** and check the brewer wiring harness.

6. With a voltmeter, check the voltage across terminals TL1 and TL4 when the "ON/OFF" switch is in the "ON" position. Connect the brewer to the power source. The indication must be 0 volts.

If voltage is as described, proceed to #7.

If voltage is not as described, disconnect the brewer from the power source and replace the timer.

7. With a voltmeter, check the voltage across terminals TL1 and TL4 when the "ON/OFF" switch is in the "ON" position. Connect the brewer to the power source and press the "START" switch. The indication must be as follows:
 - a) 120 volts ac for three wire 120/208 volt, 120/240 volt and 380 volt models.
 - b) 208 volts ac for two wire 208 volt models.
 - c) 240 volts ac for two wire 240 volt models.
 - d) 230 volts ac for two wire 230 volt CE models.
 - e) 208 or 240 volts ac for four wire 440 volt models.

If voltage is present as described, the brew timer is operating properly. Reset the timer as required, to obtain the desired brew volume.

If voltage is not present as described, disconnect the brewer from the power source and replace the timer.

Removal and Replacement:

1. Remove the two #8-32 screws securing circuit board to the mounting bracket.
2. Remove circuit board and spacers (as required).
3. Remove all wires from the timer.
4. Attach all wires to the replacement timer board prior to installation to the component mounting bracket. Refer to FIG. 33 when reconnecting the wires.
5. Install new circuit board with spacers (as required) to the component mounting bracket.
6. Adjust the timer as described below.

Timer Setting:

NOTE: Prior to setting or modifying volumes, check that the brewer is connected to water supply, the tank is properly filled, and a funnel and server are in place.

SERVICE (cont.)
DIGITAL TIMER (Late Models)

NOTE: All volume settings must be done with the sprayhead installed.

1. **Modifying brew volumes.** To modify a brew volume, first check that the SET/LOCK switch is in the “SET” position on the circuit board.

To increase a brew volume, place the ON/OFF switch in the “ON” position, press and hold the START switch until you see three breaks in the water stream from the swing arm. Release the switch and press it again one or more times. (Failure to release the switch within two seconds after the third break in the water stream causes the volume setting to be aborted and previous volume setting will remain in memory.) Each time the switch is pressed, two seconds are added to the brew time period. Allow the brew cycle to finish in order to verify that the desired volume has been achieved.

To decrease a brew volume, place the ON/OFF switch in the “ON” position, press and release the START switch once for every two-second interval to be removed from the total brew time period; then immediately press and hold down the START switch until you see three breaks in the water stream from the swing arm. Release the switch. (Failure to release the switch within two seconds after the third break in the water stream causes the volume setting to be aborted and previous volume setting will remain in memory.) Allow the brew cycle to finish in order to verify that the desired volume has been achieved.

2. **Setting brew volumes.** To set a brew volume, first check that the SET/LOCK switch is in the “SET” position on the circuit board. Place the ON/OFF switch in the “ON” position, press and hold the START switch until you see three breaks in the water stream from the swing arm and then release the switch. (Failure to release the switch within two seconds after the third break in the water stream causes the volume setting to be aborted and previous volume setting will remain in memory.)

View the level of the liquid being dispensed. When the desired level is reached, turn the ON/OFF switch to “OFF”.

NOTE: The brewer remembers this volume and will continue to brew batches of this size until the volume setting procedure is repeated.

NOTE: When brewing coffee, volume will decrease due to absorption by the coffee grounds.

NOTE: Half-Batch and full batch settings must each be set separately.

3. **Setting programming disable feature.** If it becomes necessary to prevent anyone from changing brew time once programmed, you can set the SET/LOCK switch to the “LOCK” position. This will prevent any further programming until switch is once again put into the “SET” position.

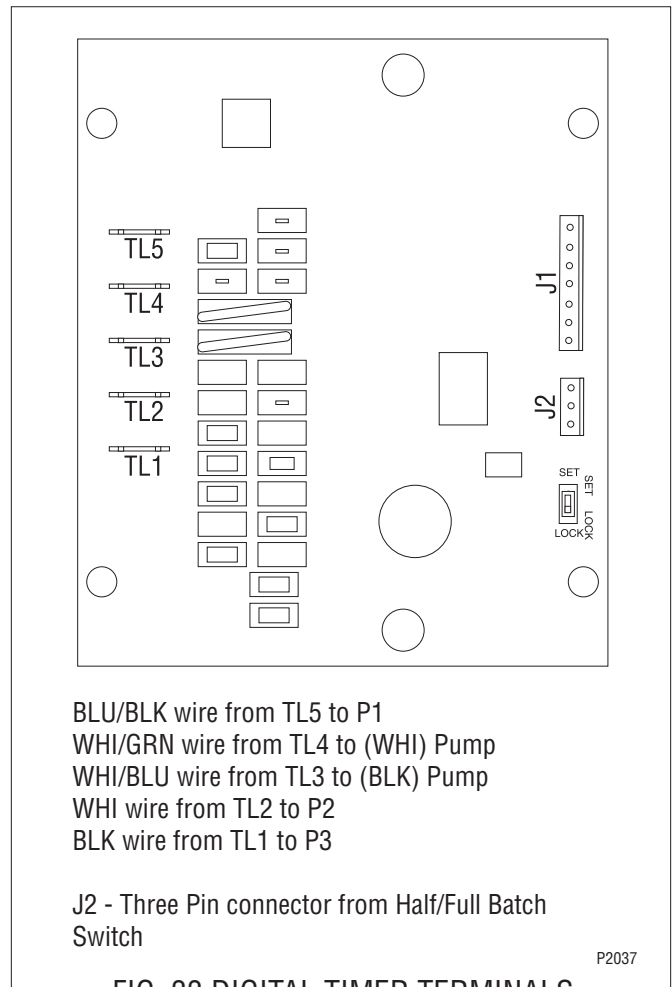

SERVICE (cont.)

TRANSFORMER (380V THREE WIRE MODELS ONLY)

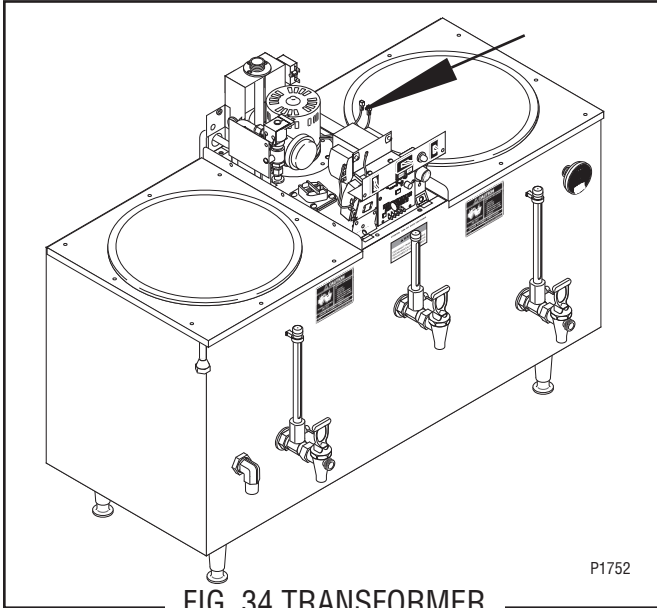

FIG. 34 TRANSFORMER

Location:

The transformer is located on the top rear of the timer mounting bracket.

Test Procedures:

1. Disconnect the brewer from the power source.
2. Disconnect black wire and the red wire from the terminal block at the transformer.
3. With a voltmeter, check the voltage across the black wire and the red wire. Connect the brewer to the power source. The indication must be 380 volts ac.
4. Disconnect the brewer from the power source.

If voltage is present as described, proceed to #5.

If voltage is not present as described, refer to wiring diagram and check the brewer wiring harness.

5. Reconnect the black wire and the red to the transformer.
6. Disconnect the black wire and the white wire from the transformer terminals.
7. With a voltmeter, check the voltage across the transformer terminals. Connect the brewer to the power source. The indication must be 120 volts ac.

If voltage is present as described, the transformer is operating properly

If voltage is not present as described, replace the transformer.

Removal and Replacement:

1. Disconnect all the wires from the transformer.
2. Remove the two #8-32 screws securing the transformer to the transformer mounting bracket.
3. Remove the transformer and discard.
4. Position new transformer on transformer mounting bracket and secure with two #8-32 screws.
5. Refer to Fig. 35 and reconnect the wires.

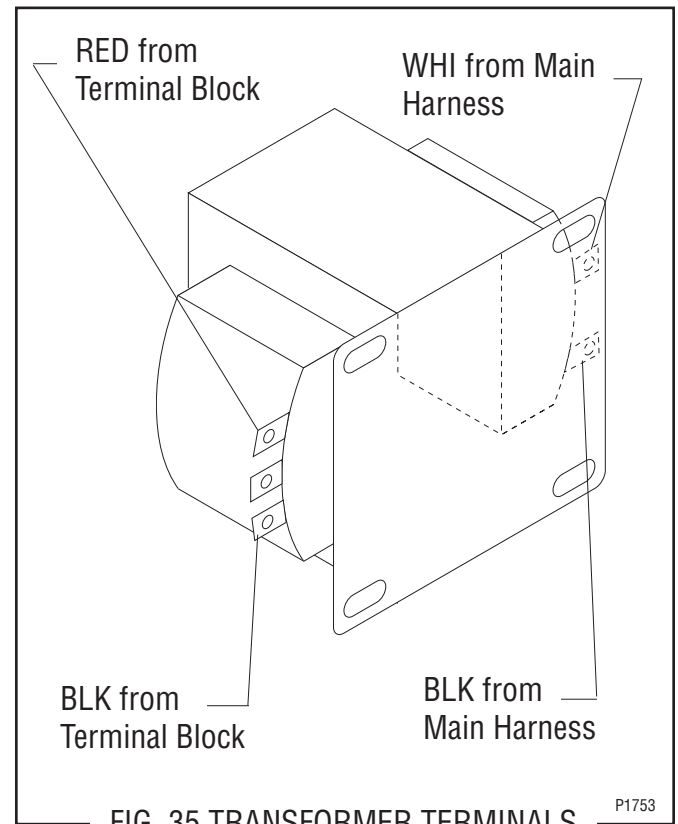
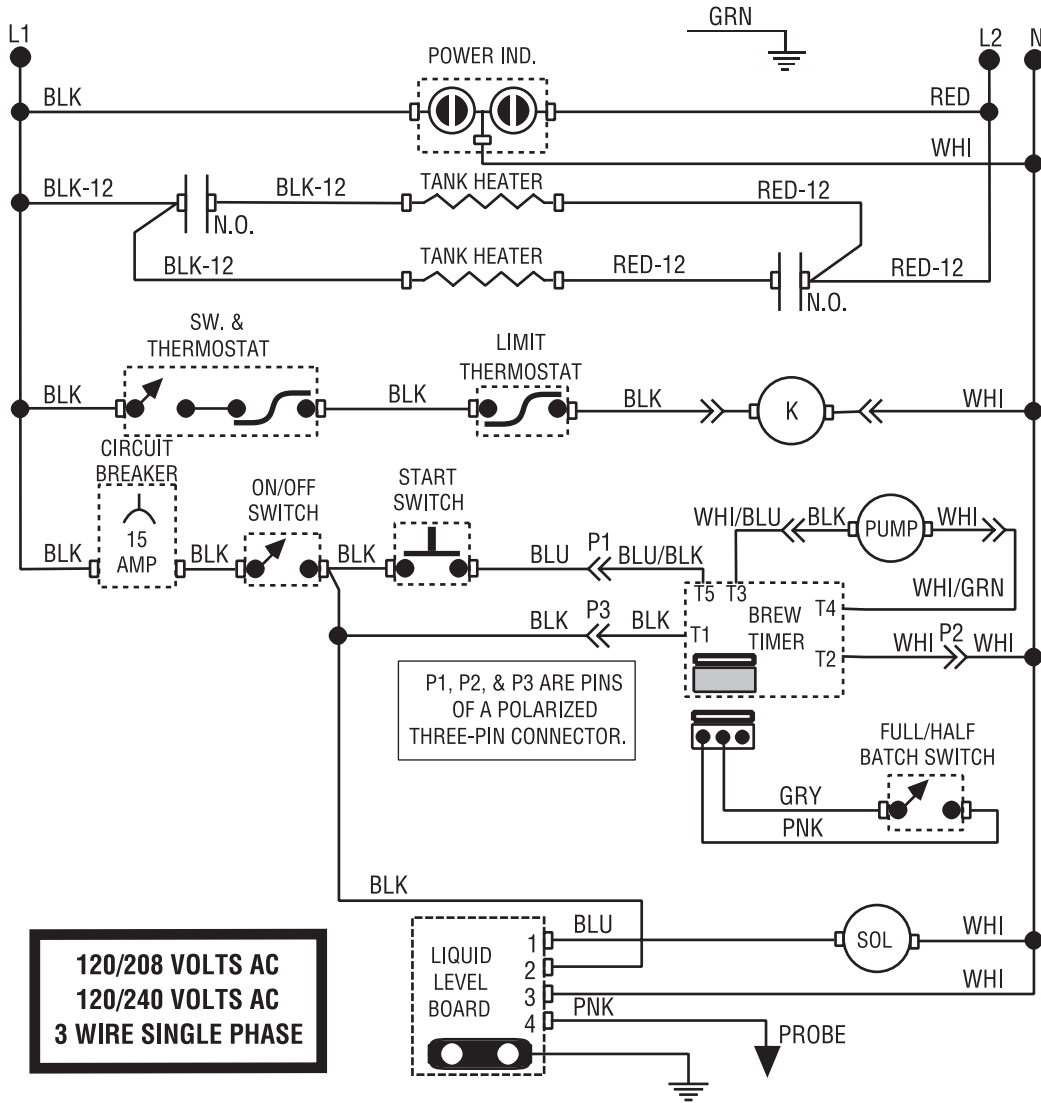
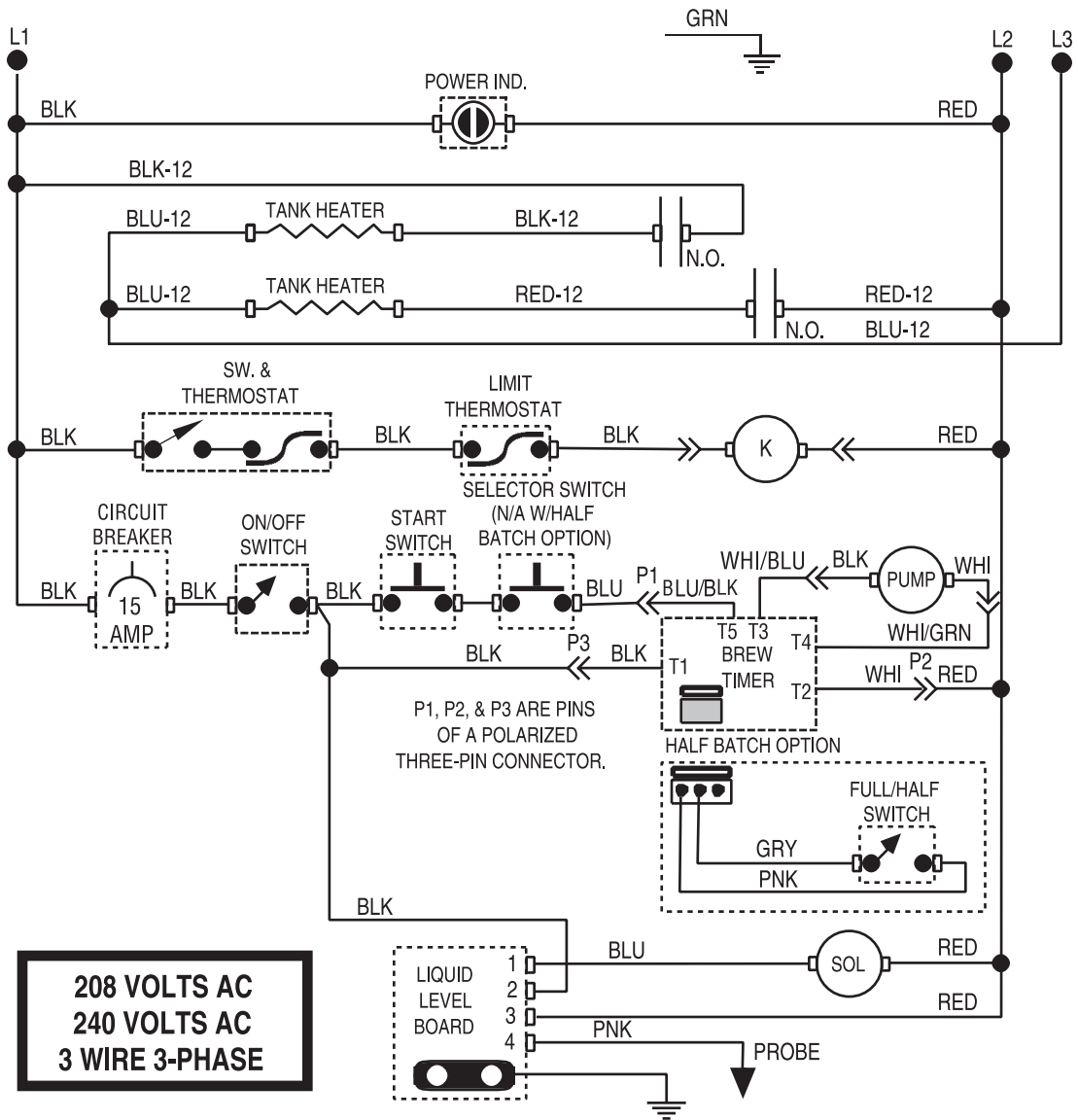

FIG. 35 TRANSFORMER TERMINALS

SCHEMATIC WIRING DIAGRAM U3 & U38



SCHEMATIC WIRING DIAGRAM U333 & U3833



SCHEMATIC WIRING DIAGRAM U3A & U38A (BREWERS PRIOR TO U300004095)

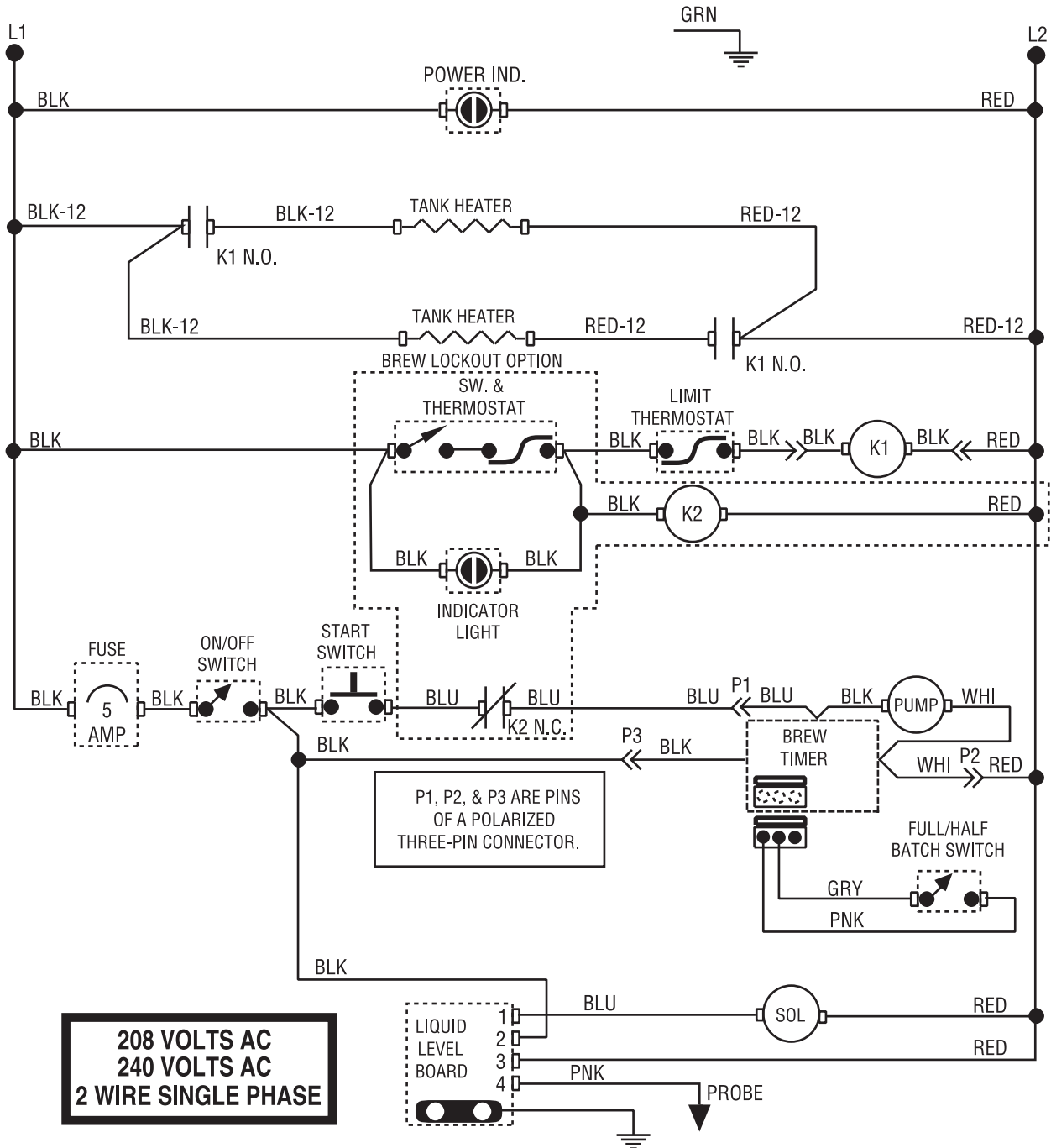

SCHEMATIC WIRING DIAGRAM U3A - CE (BREWERS S/N U300004095 - UP)

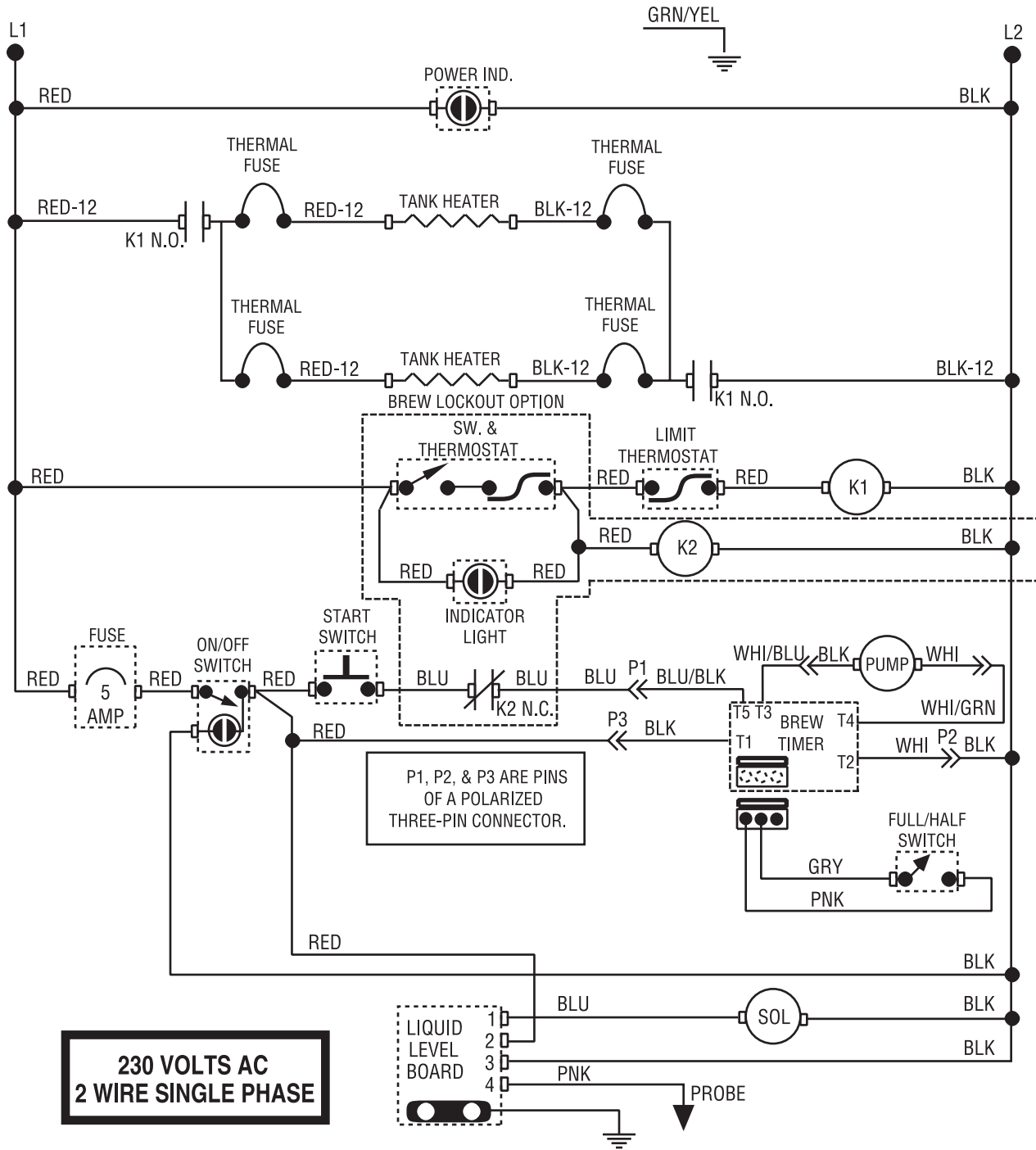

SCHEMATIC WIRING DIAGRAM U3833

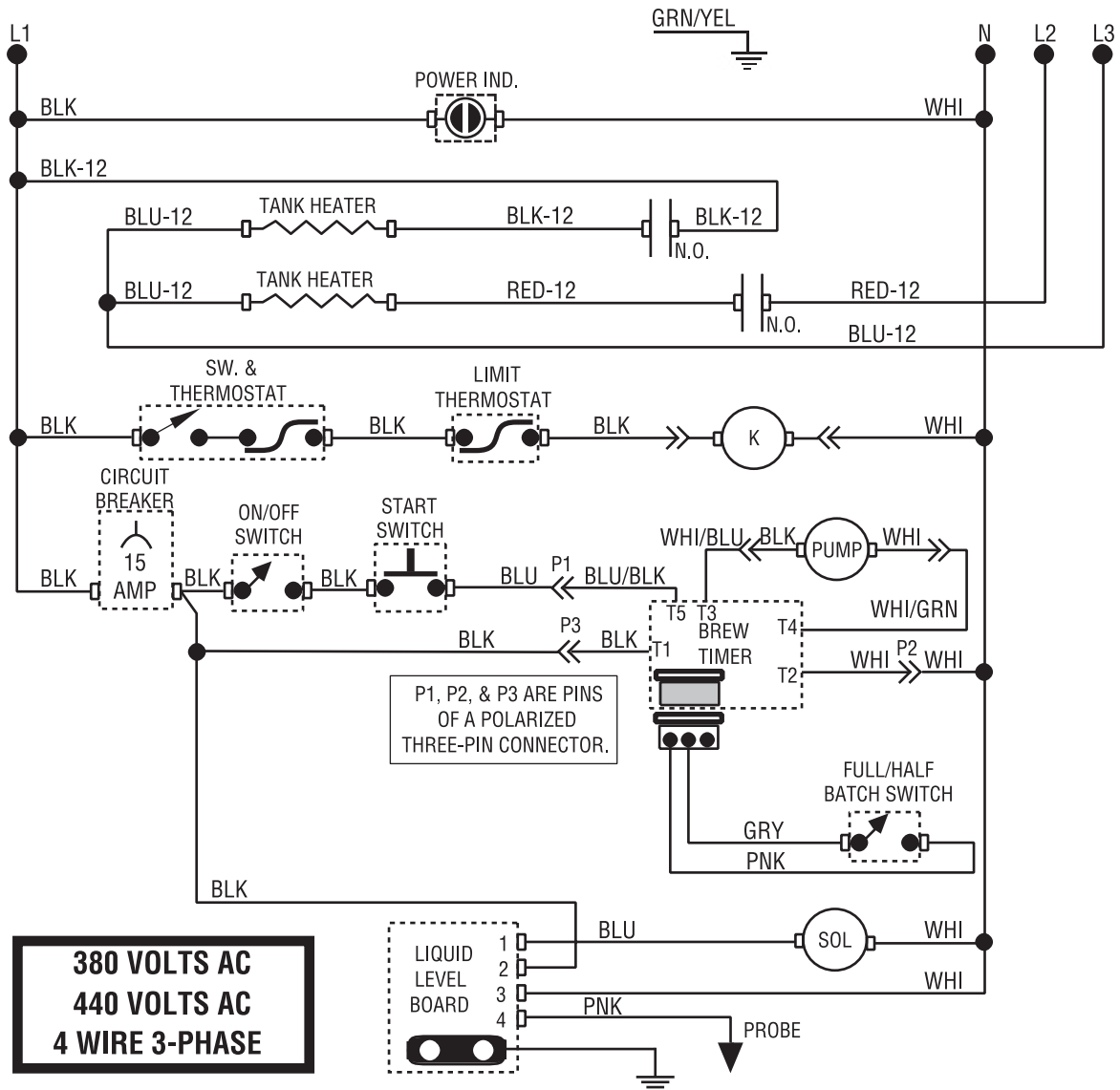

SCHEMATIC WIRING DIGRAM U3833

