

QUEST NT
4000
Service Manual

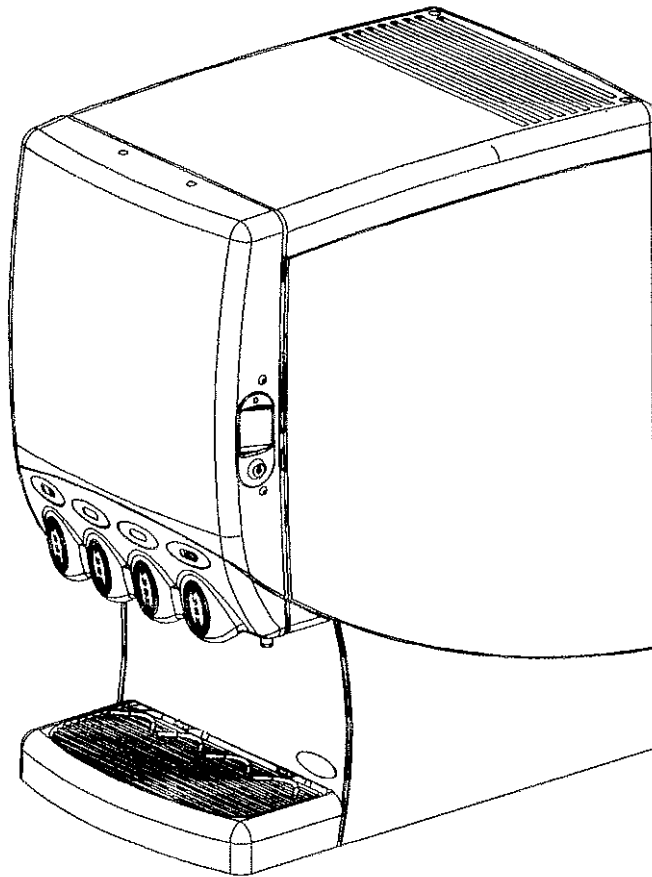

Release Date: February 19, 2004

Publication Number: 720901117SER

Revision Date: November 23, 2004

Revision: C

Visit the IMI Cornelius web site at www.cornelius.com for all your Literature needs.



QUEST NT 4000 SERVICE MANUAL

The products, technical information, and instructions contained in this manual are subject to change without notice. These instructions are not intended to cover all details or variations of the equipment, nor to provide for every possible contingency in the installation, operation or maintenance of this equipment. This manual assumes that the person(s) working on the equipment have been trained and are skilled in working with electrical, plumbing, pneumatic, and mechanical equipment. It is assumed that appropriate safety precautions are taken and that all local safety and construction requirements are being met, in addition to the information contained in this manual.

To inquire about current revisions of this and other documentation or for assistance with any Cornelius product contact:

IMI Cornelius Inc.
Corporate Headquarters
One Cornelius Place
Anoka, MN 55303-6234
U.S.A.

Internet:
www.cornelius.com

Email:
tech.service@cornelius.com

In the U.S.A.:
phone:763-421-6120
800-238-3600
FAX:800-535-4231

Outside the U.S.A.:
phone:763-421-6120
FAX:763-422-3297

Trademarks and copyrights:

Aurora, Cornelius, Decade, Hydro Boost, Sitco, Spirit, UF-1, Vanguard, Venture, Olympus, and Vista are registered trademarks of IMI Cornelius Inc.

Optifill trademark is pending.

This document contains proprietary information and it may not be reproduced in any way without permission from Cornelius.

Printed in U.S.A.

Copyright © 2004, All Rights Reserved, IMI Cornelius Inc.



TABLE OF CONTENTS

UNIT SPECIFICATIONS	1
Concentrate Handling & Loading	2
Loading Concentrate	2
Changing Concentrate Containers:	2
Brixing Procedure	3
Supplies	3
Checking/Adjusting the Brix Setting	3
Planned Maintenance Schedule	5
Daily	5
Flush System:	5
Clean Splash Zones & Dispense Nozzles:	5
Weekly	5
Sanitize the Juice Dispenser:	5
Semi-Annual	6
Clean Water Inlet Strainer:	6
Clean Chassis Interior:	6
Check and Top-Off Water Ice Bath:	6
Annually	7
Replace Pump Tubing:	7
Removing Pump Platform(s):	7
Replacing Pump Tubing:	7
Troubleshooting Guide	9
Diagrams	13
System Wiring Diagram	13
Main Electrical Box Wiring Diagram	14
Spare Parts	15
Quest Series Juice Dispenser - 115VAC (based on 10 machines)	15
Quest Series Juice Dispenser - 230VAC (based on 10 machines)	16
Warranty	17
IMI CORNELIUS INC.	17

UNIT SPECIFICATIONS

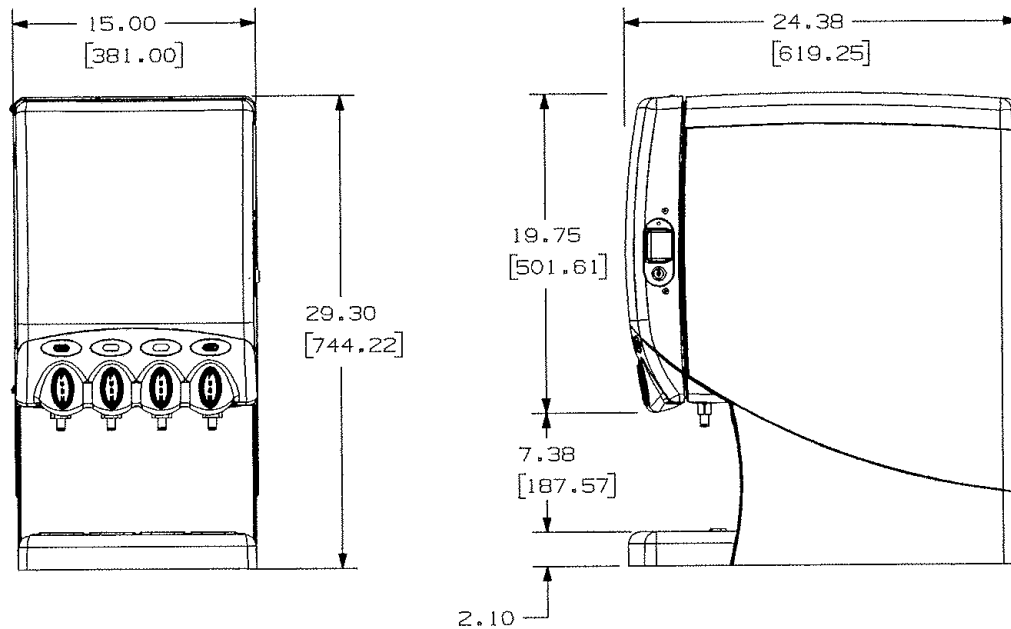

Nameplate Data: Model QST 4000, 115 VAC, 4.5 amps, 1 phase 60 hertz, 6.75 oz. (191-193g) R-134a refrigerant. Test press: High side 400 psi (27.6 bar). Low side 100 psi (6.9 bar).

Model QST 4000, 230 VAC, 3 amps, 1 phase 60hertz, 6.75 oz. (191-193g) R-134a refrigerant. Test press: High side 400 psi (27.6 bar). Low side 100 psi (6.9 bar).

Concentrate Storage: Four 0.8 gallon (3.0 liter) disposable bottles.

Clearance Recommended: 12" (30.48 cm) on top and 4" (10.16 cm) required in back for air circulation.

Electrical Connection: 6 ft. long (1.83 m) power cord with 3-prong plug attached to dispenser. Export models have line cord less plug.

Power Supply: 15 amps at 120 volts dedicated power supply.
10 amps at 230 volts dedicated power supply.

Water Connection: 3/8 in. (0.95 cm) SAE male flare fitting on dispenser.

Water Supply Requirements: 80 psi (5.5 bar) maximum static pressure. 20 psi (1.4 bar) minimum dynamic pressure; i.e., flowing pressure measured at dispenser water inlet with 3.0 ounces (88.7 ml) per second water flow, see part number 720901017 Rev. D for reference.

Ice Bank/Pull Down: Weight 14-16 lbs. Pull Down: 3.5 - 5 hours at 75°F (24°C)

CONCENTRATE HANDLING & LOADING

It is recommended that the concentrate be thawed in a refrigerated 35°F-40°F (1.6°C-4.4°C) compartment for a minimum of 48 hours prior to loading into the Quest Juice Dispenser.



WARNING: Concentrate must be completely thawed and within the temperature range of 35°F-40°F (1.6°C-4.4°C) prior to loading. Failing to supply concentrate inside the recommended temperature range, especially below 35°F (1.6°C), will cause an out of brix drink (refer to the Brixing Procedure section for details).

LOADING CONCENTRATE

The Quest Juice Dispenser is designed to use either disposable juice concentrate containers or the optional Cornelius generic refillable container sold separately.

1. Thoroughly shake concentrate prior to use.
2. Place concentrate containers on the dispensing platform shelf inside the refrigerated cabinet.
3. Engage the concentrate container by pressing it downward into the bottle adapter opening on the dispensing platform.

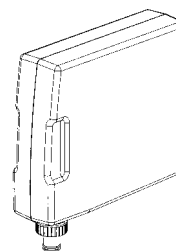

NOTE: Be sure to lubricate the o-ring seal on the container nozzle. This will ensure a good seal and allow the pumps to draw concentrated from the containers more easily. Failure to create a good seal at this connection may result in weak drinks and/or seepage of concentrate.

4. Prime each pump by closing the cabinet door and press each dispense button until concentrate flows from the dispense nozzles.

CHANGING CONCENTRATE CONTAINERS:

1. Open the cabinet door and move the valve handle from "Dispense" to "Flush"
2. Close the door. Depress and hold the dispense button until clear water flows from the dispense nozzle.
3. Open the cabinet door and return the handle to "Dispense".
4. Depress and hold the dispense button for 1-2 seconds. This will relieve water pressure from the concentrate pump system.
5. Load concentrate container (see *Loading Concentrate*).

BRIXING PROCEDURE

NOTE: If concentrate is not properly thawed, it will adversely affect the amount of concentrate dispensed. Thawed product should be between 35°F/1.6°C to 40°F/4.4°C.

SUPPLIES

- 1-Small 12 oz. cup (354.8 ml)
- 1-Large 21 oz. cup (621.1 ml)
- 1-Straw
- Paper Toweling
- 1-Thermometer
- 1-Refractometer



You will also need a flat blade screwdriver to turn a screw if brix adjustments are required.

NOTE: The refractometer shown above, P/N 511004000, is available through your local Cornelius Distributor.

CHECKING/ADJUSTING THE BRIX SETTING

The following instructions are for use with a refractometer.

1. Dispense approximately 8 oz. (236 ml) of drink and discard. Now draw a second 8 oz. drink.
2. Check drink temperature with a reliable thermometer (target is 35-45°F, or 1.6-7.2°C). Discard this drink after checking temperature.

NOTE: If drink temperature is not within the target range, refer to the basic troubleshooting section.

3. Dispense a 12 oz (354.8 ml) drink sample into a clean, dry cup. Thoroughly stir the sample using a straw.
4. Using a straw, transfer a small sample of finished drink to the refractometer lens (refer to operating instructions supplied with your refractometer). Check the brix reading against the brix chart below.

NOTE: The following brix chart is generic and intended for reference use only. Contact your frozen concentrate supplier for specific brix readings.

Brix Reference Chart		
Flavor	Ratio	Brix
Orange Juice	4+1	11.8
Grapefruit Juice	5+1	10.6
Cranberry Cocktail	4+1	13.5
Apple Juice	5+1	12.0
Grape	5+1	13.0
Lemonade	5+1	10.5
Tropical Punch	5+1	11.8
Sweetened Iced Tea	7+1	6.0
Pineapple Juice	4+1	12.8
Prune Juice	2+1	16.0

5. To change the brix setting, simply readjust the water flow rate. Located on each of the valve assemblies inside the refrigerated compartment are the adjusting screws for the water flow rate (one per valve).

If the brix reading is too high or low, rotate the appropriate water flow control according to the diagram below. Repeat steps 1-5 until the brix setting is achieved.



Lowers Brix by increasing water



Raises Brix by reducing water

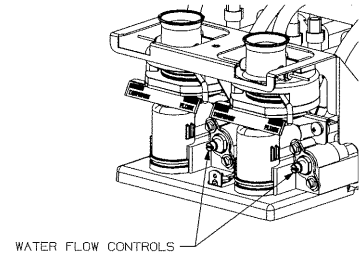

IMPORTANT: When making changes to the water flow control, do not rotate more than 1/4 turn per adjustment. Additionally, prior to taking your next brix reading, “tap” the corresponding dispense button several times prior to drawing a sample. This will clear remnant drink from the dispense nozzle AND help move the flow control to its new setting.

PLANNED MAINTENANCE SCHEDULE

DAILY

Flush System:

1. Move Dispense/Flush levers located on the platform assembly in the refrigerated cabinet to the "Flush" position. Place an empty cup on the drip tray below each dispense nozzle.
2. Close the door and depress each dispense button for 2-3 seconds or until clear water flows from each dispense nozzle.
3. Return the Dispense/Flush levers to the "Dispense" position.
4. Press each dispense button for 1-2 seconds to release the water pressure present in the concentrate pump system.

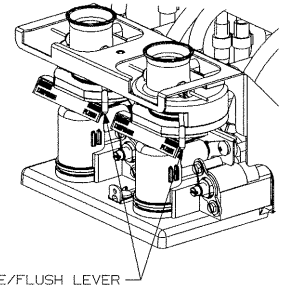

Clean Splash Zones & Dispense Nozzles:

1. On a daily basis, clean the external cabinet and splash areas using a clean damp cloth. Remove and wash the cup rest and drip tray using a mild dish soap.
2. Remove the dispense nozzles and static mixers by rotating each 90° and pulling down. Remove the mixing chambers by pulling straight forward. Wash using a mild dish soap.

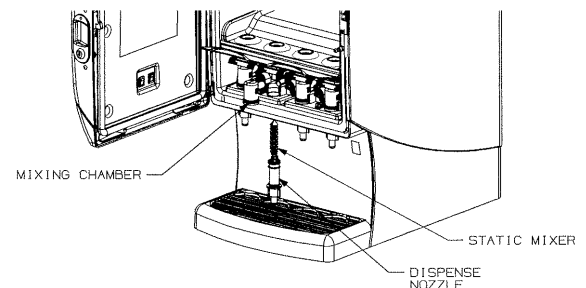

IMPORTANT: DO NOT wash nozzles, static mixers, or mixing chambers in a dish washer. This will distort the plastic and damage the o-rings. Additionally, do not soak them in sanitizing solution longer than 2 minutes.

WEEKLY

Check concentrate to water brix ratio (refer to the Brixing Procedure in this manual).

Sanitize the Juice Dispenser:

Step 1 - Rinse With Hot Water

1. Prepare two 2 oz. packets of Stera-Sheen Green Label sanitizing solution (or similar brand) by dissolving each packet in 1 gallon (3.8L) of potable water to insure 200 ppm of available chlorine.

IMPORTANT: Use potable water at 80°F-100°F (26.7°C-37.8°C). Water above this range will break-down the chlorine count and minimize sanitation.

2. Remove the juice concentrate containers and place them in separate refrigerated compartment.
3. "Flush" the system by following the instructions in the Daily Section.
4. Fill a clean empty concentrate container with one quart of extremely hot tap water, approximately 140°F (60°C) and place into unit. Dispense all of the hot water into a large container. Repeat for the remaining dispense valves.
5. Remove the mixing chambers, nozzles, and static mixers. Rinse in hot water to remove excess pulp and concentrate.
6. Place the mixing chambers, nozzles, and static mixers in a separate container of sanitizing solution and agitate vigorously. Allow the parts to soak for two minutes. Rinse thoroughly with fresh tap water.
7. Reinstall the static mixer, nozzles, and mixing chambers.

Step 2 - Sanitize Pump System

1. Fill a clean concentrate container with 2 quarts (1.9L) of fresh sanitizing solution.
2. Place handles in the "dispense" position and close the door.
3. Press and hold the dispense button for 90 seconds then stop. Allow sanitizing solution to remain in the lines for 5 minutes.
4. After 5 minutes, dispense the remaining sanitizing solution.

Step 3 - Prepare Dispenser for Use

1. Replace sanitizing solution container with a concentrate container and close the door.
2. Press and hold the dispense button until juice appears from the nozzle. Next dispense and discard at least two 8 oz. (236.6ML) cups of juice in order to prime the system and prepare it for operation.

SEMI-ANNUAL



CAUTION: The following procedures require removal of the dispenser side panel(s). Disconnect the power cord from the receptacle prior to proceeding.

Clean Water Inlet Strainer:

1. Remove the right side panel from the dispenser.
2. Turn off the water supply to the dispenser.
3. Remove the access port from the "Y" shaped water inlet solenoid located on the right side of the dispenser.
4. Clean and reinstall the stainless steel water strainer.

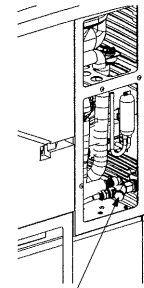

WATER STRAINER ACCESS
(RIGHT SIDE OF DISPENSER)

Clean Chassis Interior:

1. Clean the condenser cooling fins.
2. Clean the air inlet grilles located on the rear and top panels of the dispenser.
3. Clean the interior base.
4. Wipe the fan blade clean.
5. Reinstall the right side panel, turn on the water supply, and plug the dispenser into the power receptacle.

Check and Top-Off Water Ice Bath:

1. Remove the drip tray and lower splash panel.
2. If the Ice bath level is below the "Full" indicator, top it off with water. Refer to the Filling the Ice Bath procedure in the Installation section of this manual.

ANNUALLY

Replace Pump Tubing:

A replacement pump tubing kit, part#45098, is available. The kit consists of one pre-cut length of pump tubing, two white plastic hose clamps, and instructions.

Removing Pump Platform(s):

1. Remove the concentrate containers from the dispenser and place them in a refrigerator.
2. Remove the cabinet shelf that the concentrate containers sit on.
3. Flush the system prior to removing the pump platform (refer to the Daily section located at the beginning of the Planned Maintenance Schedule). Remove the dispense nozzles and static mixers.
4. Unplug the water line quick disconnect by pressing the gray button (see Fig. 1&2).
5. Slide the locking latch forward. Lift the platform slightly and pull forward to gain access to the electrical connector (see Fig.1).
6. Unplug the electrical connector by squeezing the locking tabs on either side and pulling out the connector. Lift and remove the pump platform (see Fig.1).

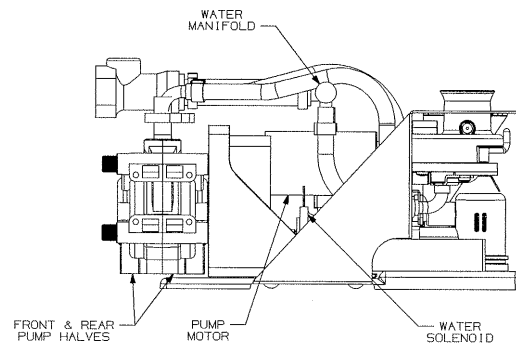
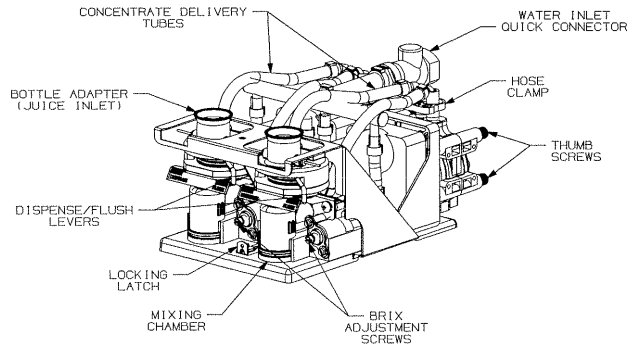

Replacing Pump Tubing:

1. Remove pump platform (refer to the Removing Pump Platform(s) procedure located earlier in this section).
2. Remove the two white plastic hose clamps from the pump tube connections (see Fig. 1&2). Remove the concentrate delivery tubes from the hose ends.
3. Loosen and remove the four screws from the pump body (see fig 3).
4. Remove the rear pump body half **only** to reveal the pump tube and rollers.
5. Remove the old pump tube from the pump body. If the roller assembly comes out with the tubing, place it back into the pump housing being sure to align the roller assembly shaft keyway to the motor shaft so that the two interlock.
6. Firmly press the new hose into the pump body around the roller assembly, being sure to keep the protruding ends even with each other.
7. Once the tubing is in place, hold the tubing with one hand, capture the lower part of the tubing with the outer housing, then proceed to capture the shaft of the roller assembly and push the rear pump housing into place. Make sure to capture the tubing within the body and not pinch it between the halves. Do not use any tool other than your finger tips to manipulate the tubing into the housing or you may damage the tube.

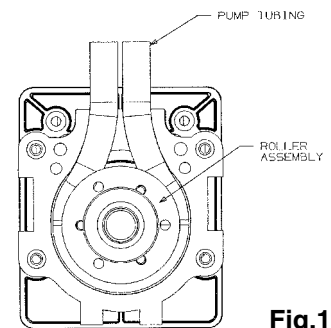

Fig.1

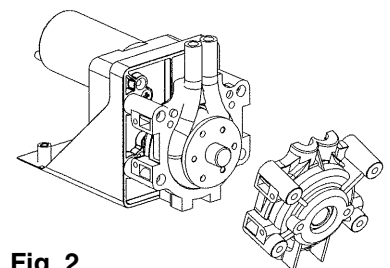
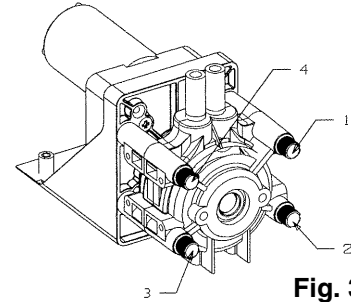

Fig. 2

8. While holding the pump halves together with your hand, reinsert the four screws and tighten using a criss-cross pattern as shown. The screws should be tightened about 1/4 turn beyond snug.
9. Insert the two concentrate delivery tubes into the pump tubing ends and secure them using the new hose clamps supplied in the kit. Be sure to use pliers to squeeze and tighten the hose clamps.

**Fig. 3**

TROUBLESHOOTING GUIDE

The following pages contain trouble-shooting information intended to aid an experienced service person in diagnosing operational problems that may occur. For further assistance, contact the IMI Cornelius Technical Services department at 1-888-248-5568 (630-539-6850 outside the United States) between the hours of 7:30A.M. and 5:00P.M. Central Standard Time. You must have the model and serial number (Located on the right side of the dispenser) prior to calling.

PROBLEM	PROBABLE CAUSE	REMEDY
Totally Inoperative	<ul style="list-style-type: none"> No power to dispenser due to tripped circuit breaker 	<ul style="list-style-type: none"> Reset circuit breaker. Confirm that breaker is correct size and no other equipment is operating on the same circuit. Also confirm that supply voltage is +/- 10% of nameplate specifications.
	<ul style="list-style-type: none"> Loose or broken power supply connection inside dispenser. 	<ul style="list-style-type: none"> Repair connection.
No cooling	<ul style="list-style-type: none"> Line voltage is not within +/- 10% of nameplate specifications causing compressor overload to trip 	<ul style="list-style-type: none"> Contact an electrician
	<ul style="list-style-type: none"> No water in water ice bath or water level extremely low exposing the ice bank sensing probe 	<ul style="list-style-type: none"> Fill ice bath to proper water level
	<ul style="list-style-type: none"> Defective Ice Bank Control or sensing probe 	<ul style="list-style-type: none"> Replace
	<ul style="list-style-type: none"> Cabinet fan is inoperative resulting in warm concentrate (water continues to cool) 	<ul style="list-style-type: none"> Replace
	<ul style="list-style-type: none"> Compressor short cycles on overload 	<ul style="list-style-type: none"> Excessively high discharge pressure due to restricted condenser or inoperative condenser fan motor
	<ul style="list-style-type: none"> Compressor starts but hums and trips overload 	<ul style="list-style-type: none"> Seized or shorted compressor, replace
	<ul style="list-style-type: none"> Defective compressor overload or start capacitor 	<ul style="list-style-type: none"> Test and replace
	<ul style="list-style-type: none"> Compressor starts but does not switch off of start winding 	<ul style="list-style-type: none"> Relay or compressor is defective. Test and replace faulty item
	<ul style="list-style-type: none"> Refrigerant leak 	<ul style="list-style-type: none"> Repair leak, evacuate and recharge system
No water dispensed, concentrate only	<ul style="list-style-type: none"> No water to dispenser 	<ul style="list-style-type: none"> Restore Water
	<ul style="list-style-type: none"> Water supply line inside refrigerated cabinet disconnected from pump platform 	<ul style="list-style-type: none"> Reconnect

PROBLEM	PROBABLE CAUSE	REMEDY
No water dispensed, concentrate only (continued)	<ul style="list-style-type: none"> Water solenoid located on pump platform clogged or defective 	<ul style="list-style-type: none"> Disassemble and clean solenoid. Replace if necessary.
	<ul style="list-style-type: none"> Main water solenoid/strainer located at the rear of dispenser is clogged, binding or defective 	<ul style="list-style-type: none"> Remove and clean strainer. Confirm 28VDC is present at solenoid during dispense. Confirm solenoid coil is not open. Disassemble and clean solenoid.
	<ul style="list-style-type: none"> Water supply pressure is greater than 80 psi (5.5 bar) forcing the brix flow control closed 	<ul style="list-style-type: none"> Add external regulator and lower pressure to 50 psi (3.5 bar)
	<ul style="list-style-type: none"> Freeze-up of water coil in ice bath 	<ul style="list-style-type: none"> Unplug dispenser and allow 2-4 hours to thaw. Check operation of agitator motor and ice bank control.
	<ul style="list-style-type: none"> 	<ul style="list-style-type: none"> Refrigeration system may be low on charge resulting in a deformed ice bank and freeze-up of the water coil in the ice bath.
No water and no concentrate, refrigeration is working	<ul style="list-style-type: none"> Black service switch located on the rear of the cabinet door in OFF position 	<ul style="list-style-type: none"> Turn on switch
	<ul style="list-style-type: none"> White door switch open 	<ul style="list-style-type: none"> Door switch must be closed in order to dispense. Check switch operation and replace if necessary.
	<ul style="list-style-type: none"> 6.25 amp fuse inside front electrical box blown 	<ul style="list-style-type: none"> Replace with 6.25, 250VAC slow blow fuse and test
	<ul style="list-style-type: none"> No output from Transformer 	<ul style="list-style-type: none"> Confirm transformer output by of 26VAC +/- 2. Replace transformer if necessary.
	<ul style="list-style-type: none"> Defective voltage regulator board (VRB) located inside front electrical box 	<ul style="list-style-type: none"> Measure across the VDC output of the board. There should be 28VDC present when the dispense button is pressed. Replaced VRB if necessary.
	<ul style="list-style-type: none"> Defective dispense push button or portion control board 	<ul style="list-style-type: none"> Test and replace if necessary
No concentrate dispensed, water only	<ul style="list-style-type: none"> Concentrate container not fully engaged into receptacle on pump platform 	<ul style="list-style-type: none"> Refer to Concentrate Loading section of this manual
	<ul style="list-style-type: none"> Dispense/Flush lever in FLUSH position 	<ul style="list-style-type: none"> Move lever to DISPENSE position
	<ul style="list-style-type: none"> Concentrate too cold, not properly thawed 	<ul style="list-style-type: none"> Concentrate should be 35-40°F (1.7-4.5°C) prior to loading

PROBLEM	PROBABLE CAUSE	REMEDY
	<ul style="list-style-type: none"> Defective pump motor 	<ul style="list-style-type: none"> Replace pump motor
Warm Drink	<ul style="list-style-type: none"> Ambient air around dispenser is too warm 	<ul style="list-style-type: none"> Relocate dispenser
	<ul style="list-style-type: none"> Excessive demand on dispenser 	<ul style="list-style-type: none"> Add water pre-cooler or second dispenser
	<ul style="list-style-type: none"> Dirty condenser coil 	<ul style="list-style-type: none"> Clean condenser coil
	<ul style="list-style-type: none"> Inoperative condenser fan 	<ul style="list-style-type: none"> Replace condenser fan motor
	<ul style="list-style-type: none"> Defective Ice Bank Control 	<ul style="list-style-type: none"> Test and replace if necessary
	<ul style="list-style-type: none"> Loss of refrigerant charge due to leak in system 	<ul style="list-style-type: none"> Repair leak and recharge system
Water continuously drips from nozzle when in OFF mode	<ul style="list-style-type: none"> Main water solenoid at base of unit or water solenoid on pump platform not shutting off tightly 	<ul style="list-style-type: none"> Clean solenoid(s), replace parts as necessary (refer to the Planned Maintenance Section)
Concentrate warm, water cold	<ul style="list-style-type: none"> Cabinet fan inoperable 	<ul style="list-style-type: none"> Check/replace fan
	<ul style="list-style-type: none"> Agitator motor/pump inoperable or restricted 	<ul style="list-style-type: none"> Check/replace agitator motor
	<ul style="list-style-type: none"> Loss of refrigerant charge due to leak in system 	<ul style="list-style-type: none"> Repair leak and recharge system
Brix Problem	<ul style="list-style-type: none"> Water supply pressure too low, less than 20 psi (1.4 bar) flowing water pressure fluctuates sharply 	<ul style="list-style-type: none"> Correct water supply problem to ensure a constant 50 psi (3.5 bar) flowing to the dispenser
	<ul style="list-style-type: none"> Water flow control binding or spring is defective 	<ul style="list-style-type: none"> Clean and/or replace parts as necessary
	<ul style="list-style-type: none"> Improperly thawed concentrate. Brix changes as the concentrate temperature changes (concentrate becomes thinner as temperature rises) 	<ul style="list-style-type: none"> Concentrate should be 35-40°F (1.7-4.5°C) prior to loading
Pump Inoperative	<ul style="list-style-type: none"> Pump motor defective 	<ul style="list-style-type: none"> 28VDC should be present at pump motor during dispense. If voltage is present and motor does not start, replace pump motor
	<ul style="list-style-type: none"> No power to transformer or no 28VAC output from transformer 	<ul style="list-style-type: none"> Confirm transformer has line voltage present on primary side. If no 28VAC output from the secondary replace transformer

PROBLEM	PROBABLE CAUSE	REMEDY
	<ul style="list-style-type: none"> Defective voltage regulator board (VRB) located inside front electrical box 	<ul style="list-style-type: none"> Confirm board produces 28VDC present when the dispense button is pressed (refer to the Electrical Box Wiring Diagram for VDC output location). Replace VRB if necessary
	<ul style="list-style-type: none"> Defective dispense control board (Push button or portion control) 	<ul style="list-style-type: none"> Test and replace if necessary
<p>Machine continues to dispense after dispense button is released or dispenses without operator input</p>	<ul style="list-style-type: none"> Push button or portion control pad stuck in on position 	<ul style="list-style-type: none"> Disconnect the wire harness from the rear of the portion control and close the door. If unit does not dispense on its own the dispense control board is bad (stuck on)
	<ul style="list-style-type: none"> Relay on voltage regulator board (VRB) stuck on. 	<ul style="list-style-type: none"> Disconnect the 4-wire harness from the lower right corner of the VRB. If the unit continues to dispense on its own the VRB is defective (relay stuck on)

DIAGRAMS

SYSTEM WIRING DIAGRAM

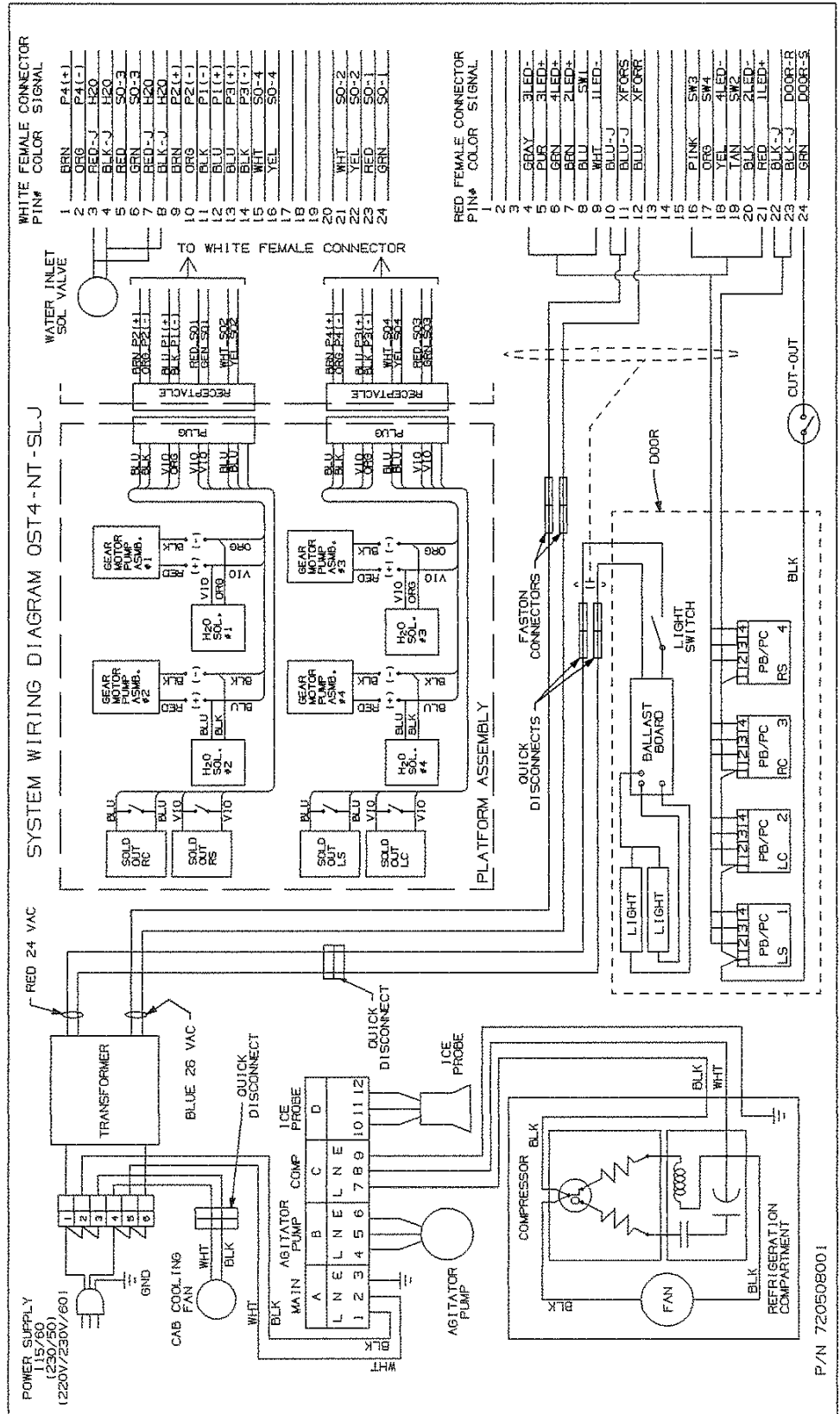

P/N 72050B001



MAIN ELECTRICAL BOX WIRING DIAGRAM

ELECTRICAL BOX WIRING

WHITE TOP CONNECTOR

PIN#	CLR	SIG	BRD#
1	BRN	J1-4	4
2	ORG	J1-3	4
3	RED	J1-2	3,4
4	BLK	J1-1	3,4
5	RED	J3-2	3
6	GRN	J3-1	3
7	RED	J1-2	1,2
8	BLK	J1-1	1,2
9	BRN	J1-4	2
10	ORG	J1-3	2
11	BLK	J1-3	1
12	BLU	J1-4	1

PIN#	CLR	SIG	BRD#
13	BLU	J1-4	3
14	BLK	J1-3	3
15	WHT	J3-2	4
16	YEL	J3-1	4
17			
18			
19			
20			
21	WHT	J3-2	2
22	YEL	J3-1	2
23	RED	J3-2	1
24	GRN	J3-1	1

RED BOTTOM CONNECTOR

PIN#	CLR	SIG	BRD#
1			
2			
3			
4	GRY	J4-2	3
5	PUR	J4-3	3
6	GRN	J4-3	4
7	BRN	J4-3	2
8	BLU	J4-4	1
9	WHT	J4-2	1
10	BLU	J3-3	3,4
11	BLU	J3-3	1,2
12	BLU	FUSE-S	

PIN#	CLR	SIG	BRD#
13			
14			
15			
16	PNK	J4-4	3
17	ORG	J4-4	4
18	YEL	J4-2	4
19	TAN	J4-4	2
20	BLK	J4-2	2
21	RED	J4-3	1
22	WHT	J3-4	3,4
23	WHT	J3-4	1,2
24	BLU	FUSE-R	

P/N 720500716 REV. A

SPARE PARTS

QUEST SERIES JUICE DISPENSER - 115VAC (BASED ON 10 MACHINES)

Part Number	Description	Qty
729011132	Kit, Parts - Stocking	1
560004360	Condenser Fan, Motor 115VAC	1
18071	Seat, Armature - Water Valve	2
18367	Spring, Coil S/S - Water Solenoid	2
31314	Fluorescent Bulb	2
45028	Transformer, 115VAC	1
45098	Pump Tubing Kit	4
45432	Inner Door Switch	1
7215323	Armature - Water Solenoid	1
7245699	Flow Control/Bonnet Assembly	2
620710107	Rubber Gasket	2
19695001	Guide, Water Solenoid	1
31525037	O-Ring - Dispensing Nozzle	2
45012102	Voltage Regulator Board	2
45016001	Pump Gear Motor	2
45026100	Bottle Adapter O-Ring Kit (all O-rings in bottle adapter)	1
45091001	Main Water Solenoid Valve	1
45728001	Pump Rotor Assembly	1
48520001	Coil, 24VDC, Valve Block	1
48979103	Spool & Sleeve Asmb w/ 31525-060 O-Ring	2
59328001	Fuse, 6.25 Amp, 250VAC	4
440000902	Global Ice Bank Control (115VAC)	1
720500014	Drip Tray Grill	1
720500104	Drip Tray	1
720500710	Door Gasket	1
720202009	Catch w/switch	1
720502800	Agitator Motor	1
720503201	Compressor, 115V/60Hz, R-134a	1
720503206	Overload, Compressor, 115VAC	1
720503207	Relay, Compressor, 115VAC	1
720503208	Capacitor, Compressor, 115VAC	1
720506104	Cabinet Fan, 115VAC	2
720507101	Dispense Nozzle, Static Mixer, & O-Ring	1
720508801	Push Button Control Board	1
720508802	Portion Control Board	2
720511606	Ballast Board	1
720703502	Foam Gasket, Lower Door	1
720704001	Latch, Door	1
720501504	Condenser	1
720504904	Frame Assy, Base	1

QUEST SERIES JUICE DISPENSER - 230VAC (BASED ON 10 MACHINES)

Part Number	Description	Q t y
729011132	Kit, Parts - Stocking	
560004361	Condenser Fan, Motor 230VAC	1
18071	Seat, Armature - Water Valve	2
18367	Spring, Coil S/S - Water Solenoid	2
31314	Fluorescent Bulb	2
720500794	Transformer, 230VAC	1
45098	Pump Tubing Kit	4
45432	Inner Door Switch	1
7215323	Armature - Water Solenoid	1
7245699	Flow Control/Bonnet Assembly	2
620710107	Rubber Gasket	2
19695001	Guide, Water Solenoid	1
31525037	O-Ring - Dispensing Nozzle	2
45012102	Voltage Regulator Board	2
45016001	Pump Gear Motor	2
45026100	Bottle Adapter O-Ring Kit (all O-rings in bottle adapter)	1
45091001	Main Water Solenoid Valve	1
45728001	Pump Rotor Assembly	1
48520001	Coil, 24VDC, Valve Block	1
48979103	Spool & Sleeve Asmb w/ 31525-060 O-Ring	2
59328001	Fuse, 6.25 Amp, 250VAC	4
440000901	Global Ice Bank Control (230VAC)	1
720500014	Drip Tray Grill	1
720500104	Drip Tray	1
720500710	Door Gasket	1
720202009	Catch w/switch	1
720502803	Agitator Motor	1
720503202	Compressor, 230V/50Hz, R-134a	1
720503209	Overload, Compressor, 230VAC	1
720503210	Relay, Compressor, 230VAC	1
720506104	Cabinet Fan, 230VAC	2
720507101	Dispense Nozzle, Static Mixer, & O-Ring	1
720508801	Push Button Control Board	1
720508802	Portion Control Board	2
720511606	Ballast Board	1
720703502	Foam Gasket, Lower Door	1
720704001	Latch, Door	1
720501504	Condenser	1

WARRANTY

IMI CORNELIUS INC.

Certificate of Warranty

ONE YEAR LIMITED BEVERAGE EQUIPMENT WARRANTY

IMI Cornelius Inc. warrants to the original commercial purchaser/user, that any commercial product of its manufacture bearing the name Wilshire will be free from defect in material and/or factory workmanship, and that if properly installed, maintained, and serviced in accordance with the Service Manual furnished with the product, it will perform adequately under normal use. This product warranty shall be effective for a period of one year from the date of original installation or 15 months from the date of original shipment by IMI Cornelius, whichever period elapses first.

IMI Cornelius Inc.'s obligation under this warranty is strictly limited to the replacement of any parts which the purchaser/user returns to IMI Cornelius Inc.'s factory, transportation costs prepaid, and which IMI Cornelius finds to be defective in workmanship and/or material within the warranty period. The serial and model numbers and date of original installation of the product must be given. No part or assembly which has been subjected to accident, alteration, or misuse or which is not installed, maintained, or serviced in accordance with Service Manual furnished with the product, or which is from a machine on which the serial number has been removed, shall be covered by this warranty. This warranty does not provide for service calls from factory representatives or from any other agencies and shall not include charges of any nature.

IMI Cornelius Inc. will accept a part, parts, or equipment freight prepaid and return same freight collect to the sender within the continental U.S. or port of export within the continental limits of the U.S. IMI Cornelius Inc. is not responsible for international freight, customs fees or duties at country of destination.

ADDITIONAL FOUR YEAR LIMITED WARRANTY ON COMPRESSOR

This warranty shall be effective for a period of four (4) years from the expiration of the above warranty.

The hermetically sealed refrigeration compressor is covered by the above one year limited warranty. In addition to that warranty, if the compressor fails because of a defect in materials or workmanship during the second through fifth year from the date of installation, IMI Cornelius Inc. will repair or, at its option, replace the compressor. Labor charges and the cost of relays, overloads, and capacitors are not included.

THIS WARRANTY DOES NOT COVER DAMAGED CAUSED BY LACK OF PREVENTATIVE MAINTENANCE, IMPROPER INSTALLATION, ACCIDENT, MISUSE, NEGLIGENCE, ALTERATION, FIRE, FLOOD, OR ACTS OF GOD. In those jurisdictions where liability for damages cannot be disclaimed, original purchasers recovery shall not exceed the cost of the warranted product.

IMI CORNELIUS INC. ASSUMES NO LIABILITY FOR INCIDENTAL OR CONSEQUENTIAL DAMAGES OF ANY KIND, INCLUDING, BUT NOT LIMITED TO, SPOILED PRODUCT, LOST PROFITS, OR DAMAGE TO OTHER PROPERTY.

THIS WARRANTY IS EXCLUSIVE AND IN LIEU OF ALL OTHER WARRANTIES, WHETHER WRITTEN, ORAL, OR IMPLIED, INCLUDING ANY WARRANTY OF MERCHANTABILITY OR FITNESS FOR A PARTICULAR PURPOSE, AND SUPERSEDES AND EXCLUDES ANY ORAL WARRANTIES OR REPRESENTATIONS OR WRITTEN LANGUAGE IN ANY MANUAL, LITERATURE, ADVERTISING BROCHURE OR OTHER MATERIALS NOT EXPRESSLY DESIGNATED IN WRITING AS A "WARRANTY".

IMI Cornelius Inc.
www.cornelius.com