

Crathco® Powdered Beverage Dispensers

Service Manual

for

PIC 1, 2, 3, 4, 5, 6

PSD 1, 2, 3, 4, 5, 6

PIC 23A, PIC33A, PIC43A, PIC5W

TABLE OF CONTENTS

Warning Labels.....	2
Installation.....	4
Start up Procedures.....	4
How To Dispense Cappuccino.....	5
Adjustments.....	5
Cleaning.....	7
Preventative Maintenance	11
Service	
Light Bulbs.....	12
Draining the Tank	12
Shipment Preparation	12
Whipper Motors	13
Dump Valves	14
Grommets	14
Water Tank	14
Inlet Valve	16
Thermistor	17
Auger Motors	18
Blower Motor	18
Controller	18
Heater Relay	18
Transformer	18
Soluble Conversion	19
Troubleshooting.....	20
Exploded Views.....	22
Wiring Diagram.....	50



PIC 1



PIC 2



PIC 33A



PIC 5



PIC 6

Prior authorization must be obtained from Grindmaster Corporation™ for all warranty claims.



Grindmaster Corporation™

4003 Collins Lane
 Louisville, Kentucky 40245 USA
 (502) 425-4776
 (800) 695-4500 (USA and Canada only)
 (800) 568-5715 (Technical Service only)
 FAX: (502) 425-4664
www.grindmaster.com

Warning Labels

The following warning labels were on your dispenser when it was shipped from the factory. They should remain on your dispenser in good, readable condition at all times. If one of your labels is missing or damaged, order a replacement label immediately.

Part #62981 (PIC 5-6) - Located on the upper splash panel on the front of the dispenser



Part #61321 (PIC 1-4) - Located behind the drip pan on the front of the dispenser

⚠ WARNING: Risk of electric shock. Disconnect from power before servicing. Hot parts and surfaces inside and outside machine may cause burns. Tank drain hose inside machine dispenses very hot water. Will cause burns and/or personal injury. Must have five gallon heat resistant container to catch hot water. Hot water may splash. Do not attempt to stop hot water once it begins flowing. Replace plug and clamp prior to refilling tank.



Part #100268 (PIC 5-6) - Located behind the drip pan on the front of the dispenser

⚠ WARNING:	Risk of electric shock. Disconnect from power before servicing.
⚠ ADVERTENCIA:	Riesgo de shock eléctrico. Desconecte antes de hacer el servicio.
⚠ AVERTISSEMENT:	Risque de décharge électrique. Débrancher la machine avant tout entretien.
⚠ WARNUNG:	Elektroschlag Gefahr! Vor Handhabung des Gerätes bitte vom Stromnetz trennen.
⚠ ATTENZIONE:	Rischio di shock elettrico. Togliere la tensione prima di intervenire.



PN# 100268

Warning Labels (cont.)





Part #61319, Located on the outside on the back of the dispenser

 WARNING:	 ADVERTENCIA:	 AVERTISSEMENT:
RISK OF ELECTRIC SHOCK. DISCONNECT FROM POWER BEFORE SERVICING. HOT PARTS AND SURFACES INSIDE MACHINE MAY CAUSE BURNS.	RIESGO DE CHOQUE ELECTRICO. DESCONECTE LA MAQUINA DE LA CORRIENTE ANTES DE ARREGLARA. PIEZAS Y SUPERFICIES CALIENTES DENTRO DE LA MAQUINA PUEDEN CAUSAR QUEMADURAS.	DANGER DE CHOC ELECTRIQUE. METTRE L'APPAREIL HORS TENSION AVANT DE L'ENTREtenir. DES ELEMENTS ET SURFACES CHAUDS PEUVENT PROVOQUER DES BRULURES. MANIPULER AVEC SOIN.
IMPORTANT CONNECT TO A WATER SUPPLY BEFORE PLUGGING IN.	IMPORTANTE CONECTE LA MAQUINA A UNA VIA DE AGUA ANTES DE ENCHUFARLA.	IMPORTANT RACCORDER L'APPAREIL A LA DISTRIBUTION D'EAU AVANT DE METTRE SOUS TENSION. 61319

Part #61326, Located on the outside on the left of the dispenser

 WARNING:	 ADVERTENCIA:	 AVERTISSEMENT:
HOT PARTS AND SURFACES MAY CAUSE BURNS.	PIEZAS Y SUPERFICIES CALIENTES DENTRO DE LA MAQUINA PUEDEN CAUSAR QUEMADURAS.	DES ELEMENTS ET SURFACES CHAUDS A L'INTERIEUR DE L'APPAREIL PEUVENT PROVOQUER DES BRULURES.
ADJUSTMENT INSTRUCTIONS ON THE BACK OF THE ACCESS PANEL.	INSTRUCCIONES DE AJUSTE DENTRO DEL PANEL DE ACCESO.	CONSIGNES DE REGLAGE AU VERSO DE LA PLAQUE D'ACCES. 61326

Part #61325, Located on the drain hose inside the dispenser

<p> WARNING VERY HOT WATER MAY CAUSE BURNS</p> <p>IMPORTANT</p> <ul style="list-style-type: none"> • YOU MUST HAVE A 6 GALLON HEAT RESISTANT CONTAINER TO CATCH HOT WATER. • TO EMPTY HOT WATER FROM TANK REMOVE CLAMP, PINCH THE TUBE AND UNPLUG HOSE. DO NOT ATTEMPT TO STOP WATER ONCE IT BEGINS FLOWING. • REPLACE PLUG AND CLAMP PRIOR TO REFILLING TANK. 	<p> ADVERTENCIA AGUA MUY CALIENTE PUEDE CAUSAR QUEMADURAS</p> <p>IMPORTANTE</p> <p>UD DEBE TENER UN RECIPIENTE RESISTENTE AL CALOR DE 6 GALONES PARA GUARDAR AGUA CALIENTE. PARA VACIAR EL AGUA CALIENTE DEL DEPOSITO, quite LA ABRAZADERA, APRETE EL TUBO Y DESCONECTE LA MANGUERA. NO TRATE DE DETENER EL AGUA UNA VEZ QUE EMPIECE A FLUIR. REEMPLAZA EL TAPON U SUIETE EL TURBO ANTES DE RELLENAR EL DEPOSITO.</p>	<p> AVERTISSEMENT L'EAU TRES CHAUDE PEUT PROVOQUER DES BRULURES</p> <p>IMPORTANT</p> <p>IL FAUT UN RECIPIENT RESISTANT AL LA CHALEUR D'UNE CAPACITE DE 6 GALLONS (23LITRES) POUR RECUEILLIR L'EAU CHAUDE DU RESERVOIR. POUR VIDER LE RESERVOIR, ENLEVER LE SERRE-JOINT. PINCHER LE TUBE ET RETIRER LE TUYAU. NE PAS ARRETER L'ECOULEMENT D'EAU. AVANT DE REMPLIR A NOUVEAU LE RESERVOIR, REPLACER LA FICHE ET LE SERRE JOINT.</p>	<p> WARNUNG SEHR HEISSES WASSER KANN ZU VERBRENNUNGEN FÜHREN.</p> <p>WICHTIG:</p> <p>WASSER MUSS IN EINEM 23L HITZEBESTÄNDIGEN GEFÄSS AUFGEFANGEN WERDEN. ZUR ENTLERUNG DES HEISSEN WASSERS DEN ABLASCHLAUCH ZUSAMMENDRÜCKEN UND HERAUSZIEHEN. LAUFENDES WASSER NICHT AM ABFLUSS HINDERN. STÖPSEL UND KLAMMER VOR DEM AUFFÜLLEN WIEDER ANBRINGEN.</p>	<p> AVVERTENZA ACQUA BOLLENTE. RISCHIO DI USTIONI</p> <p>IMPORTANTE</p> <p>È NECESSARIO DISPORRE DI UN CONTENITORE DA 23 LITRI ADATTO A RACCOLGERE L'ACQUA BOLLENTE. PER VUOTARE IL SERBATOIO, RIMUOVERE IL MORSETTO, PREMIERE E SFILARE IL TUBO. È PERICOLOSO CERCARE DI BLOCCARE L'ACQUA BOLLENTE QUANDO COMINCIA AD USCIRE. RIMONTARE LA PRESA E IL MORSETTO PRIMA DI RIEMPIRE MOVAMENTE IL SERBATOIO.</p>	<p> WAARSCHUWING: KOKEND-HEET WATER KAN BRANDWONDEN VEROOZAKEN</p> <p>BELANGRIJK!</p> <p>MIEN MOET EEN 23-LITER MITTEWEREND VAT HEBBEN OM HET HEETE WATER IN OP TE VANGEN. OM HET HEETE WATER UIT DE TANK TE VERWIJDEREN, MOET MIEN DE KLEM LOSMAKEN, DE BAND INKLIJPEN EN DE SLANG UITREMIEN. ALS HET WATER BEGINT TE LOPEN, NIET MEER ONDERBREKEN. HERPLANTS STOP EN KLEM ALVORENS DE TANK OPNIEUW TE VULLEN. 61325</p>
--	--	--	--	--	---

Installation

Water Inlet Connection

The following is required for water hook-up:

1. A quick disconnect water connection or enough coiled tubing so the machine can be moved for cleaning underneath. *(required for NSF approved water hook-up)*
2. A 1/4" male flare adapter is provided (packed inside the drain tray) to be attached by the installer to the back of the machine for hook-up to water supply.
3. Installation to a water filter system is required to prevent lime and scale build up in the machine.
4. Water pipe connections and fixtures directly connected to potable water supply shall be sized, installed, and maintained in accordance with Federal, State, and Local codes. *(required for NSF approved water hook-up)*
5. Equipment is to be installed with adequate backflow protection to comply with applicable Federal, State, and local codes. *(required for NSF approved water hook-up)*

Start-up Procedure for Standard Units

NOTE: NSF requires installation of 4" legs for PIC 2,3,4,5,6.

1. Install drip tray in front of machine.
2. Connect the 1/4" male flare fitting to the inlet valve on the back of the machine.
3. Flush the water line to purge any debris from the supply line.
4. Connect a 1/4" water line to the 1/4" male flare connection and turn the water supply on.
 - a. Minimum water pressure to the machine: 20 psi
 - b. Maximum water pressure to the machine: 100 psi
5. Plug the power cord into a proper electrical outlet.
6. Turn the power switch to the "ON" position and allow the water tank to fill. The machine will make a subtle hissing sound when this occurs. Allow 3-4 minutes (5 minutes for PIC 5 or PIC 6) for fill time depending on inlet water pressure.

NOTE: If water supply is allowed to run dry, watchdog timer circuit may disable fill circuit. If this occurs, ensure adequate water supply for machine, then reset machine by turning power switch "OFF" for 1 second and then turning the power switch back "ON".

NOTE: Watchdog timer might engage on initial fill on PIC 5 and PIC 6.

7. After the water tank has filled, allow 15-45 minutes (45-60 minutes for PIC 5/6) for the water to reach operating temperature. (Green ready light will illuminate when tank is up to preset temperature.)
8. Remove the powder hoppers, rotate the dispense elbow to the "up" position, and fill with desired powder product. **IMPORTANT:** Check to make sure that the auger inside the hopper is correctly installed prior to filling. Reinstall powder hoppers. Turn dispense elbow down toward the mixing funnel.
9. Peel protective film off photo merchandiser cover. (Install graphic if needed)
10. Install flavor decals as needed. (Place one on each hopper, and place the corresponding decal on the dispense section of the front door of the unit)

POWER CORD TABLE

Models	Volts	Watts	Phase	Supply Cord	Attachment Plug	Agency
Standard Models	120V	1400W	Single Phase 60Hz	14-3	5-15	UL, CUL, NSF
	120V	1650W		14-3	5-15	UL, NSF
	120V	1650W		12-3	5-20	UL, CUL, NSF
Q	120/208-240	2500W		12-4	L14-20	UL, CUL, NSF
Z*	208-240	2500W		12-4	L14-20	UL, CUL, NSF

* For Z model neutral is not required.

Start-Up Procedures for Pump Units (PIC 2P & PIC 3P only)

NOTE: Pump units are not designed to be plumbed to pressurized water source.

1. Place a five gallon water container within 3 feet vertically and 2 feet horizontally of the machine.
2. Drop the hose at the rear of the machine into the water container (The hose should extend to approximately 1" from the bottom of the water container.)

Installation (cont.)

Start-Up Procedures for Pump Units (PIC 2P & PIC 3P only) (cont.)

NOTE: Do not let the end of the hose touch the bottom of the container. Shorten the hose if necessary. If you need a longer hose, remove the back access panel, unclamp existing hose, replace with longer hose and replace clamp.

3. Proceed with fifth step under Start Up for Standard Units.

How to Dispense a Cup of Cappuccino

On models with manual dispense switches (Refer to serial tag to verify model number of your machine)

1. Place cup under the selected drink dispense nozzle.
2. Push and hold the appropriate switch on the touchpad until cup is 2/3 full and then release switch.

On models with portion control (single portion or 3 portion per head): (optional on PIC 2, 3, & 4 only)

1. Place cup under the selected drink dispense nozzle.
2. Push appropriate switch on the touch pad, then release to dispense one preset serving. (see **Portion Control Adjustment** to set portion size)

NOTE: Portion may be cancelled by push and release of the switch during dispensing.



CAUTION: Cup must rest flat on tray with a 1/4" (6 mm) clearance between cup and spout. Contents can cause severe burns if handled improperly.

Adjustments

Portion Adjustment

If machine is a manual dispense, there are no portion control adjustments to be made. (Please refer to serial tag to reference model number.)

SETTING SINGLE PORTION CONTROL

1. Place a cup under the selected drink dispense nozzle.
2. Press and hold the dispense switch.
3. After a 10 second time delay, the machine is triggered into program mode and will begin dispensing.
4. Continue pressing the button until cup is approximately 2/3 full, then release the switch to prevent overflow. The elapsed portion dispense time is saved to memory and will remain until the dispense switch is reprogrammed.
5. Check the portion size by placing an empty cup under the desired dispense nozzle, then press and release the dispense switch. The machine will dispense the preprogrammed portion size.
6. If the portion size is incorrect, repeat above steps until the desired portion size is achieved. Each dispense switch needs to be set separately.

SETTING THREE PORTION SIZES PER HEAD (optional on PIC 2/3/4 only)

1. Place a cup under the selected drink dispense nozzle.
2. Press and hold the size button on the touch pad that you wish to program or set. (Hold button throughout entire procedure.)
3. Press and release the manual (top-off) button. After releasing the manual (top-off) button, the 10-second delay is activated.
4. Continue pressing the size button until cup is approximately 2/3 full, then release the switch to prevent overflow. The elapsed portion dispense time is saved to memory and will remain until the dispense switch is reprogrammed.
5. Check the portion size by placing an empty cup under the desired dispense nozzle, then press and release the dispense switch. The machine will dispense the preprogrammed portion size.
6. If the portion size is incorrect, repeat above steps until the desired portion size is achieved. Each portion size for each head needs to be set separately.

Thermostat Adjustment

NOTE: The thermostat range is approximately 160°F to 200°F. The tank temperature is factory set at 180°F, making the beverage temperature slightly lower than 180°F.

1. Unplug machine.
2. Remove the drip tray.
3. Remove the upper splash panel on the front of the machine by removing the four Phillips head screws.
4. Locate the thermostat adjustment dial on the control board(s).
5. To adjust the temperature of the water being dispensed, turn the adjustment dial on the large* control board. (Turn clockwise to increase the water temperature or counterclockwise to decrease the water temperature)

NOTE: It will take time for the water tank temperature to reach its adjusted temperature setpoint.

CAUTION: Do not force the adjustment dial beyond its 270° of rotation or damage to the control board may occur.

*NOTE: PIC 4, 5, and 6 have a second controller. The temperature dial on the right hand board is not active on this board.

Drink Strength Adjustment

(Refer to Figure A and B)

Tools Required: #2 Phillips Screwdriver

Warning: Risk of Electric Shock! Always turn off power to machine while servicing or making internal adjustments to machine.

1. Dispense a drink to determine if drink is too strong or too weak.
2. Turn off power to machine at power switch.
3. Remove upper front splash cover below dispense heads in front of machine.
4. Using a flat head screwdriver, adjust individual dispense heads by rotating appropriate adjustment knob. Turn on power to machine and dispense a drink to determine if drink strength is acceptable. If drink is not acceptable, turn off power to machine and repeat adjustment steps until desired drink strength is achieved.

Note: Clockwise rotation will result in a stronger drink and counterclockwise will result in a weaker drink.

Note: Water flow rate is factory preset at approximately 0.80 ounces per second.

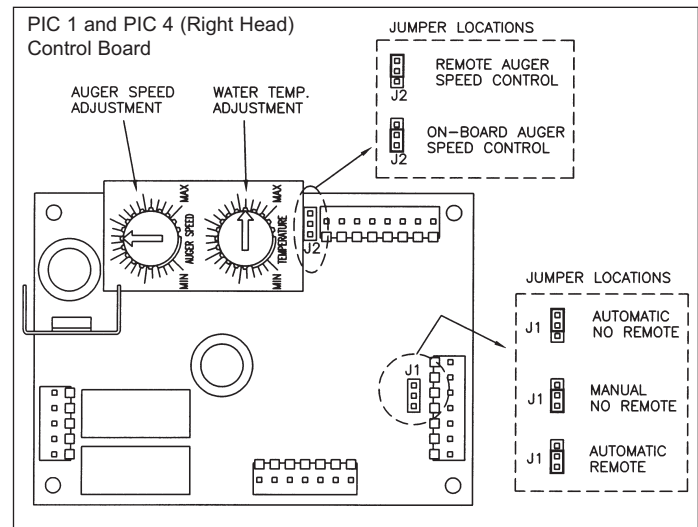
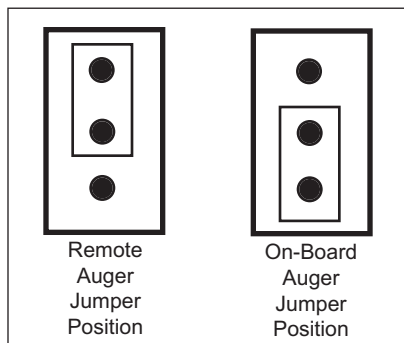

Figure A Operates PIC and right head on PIC4. Thermostat dial on this board is not used on PIC4.

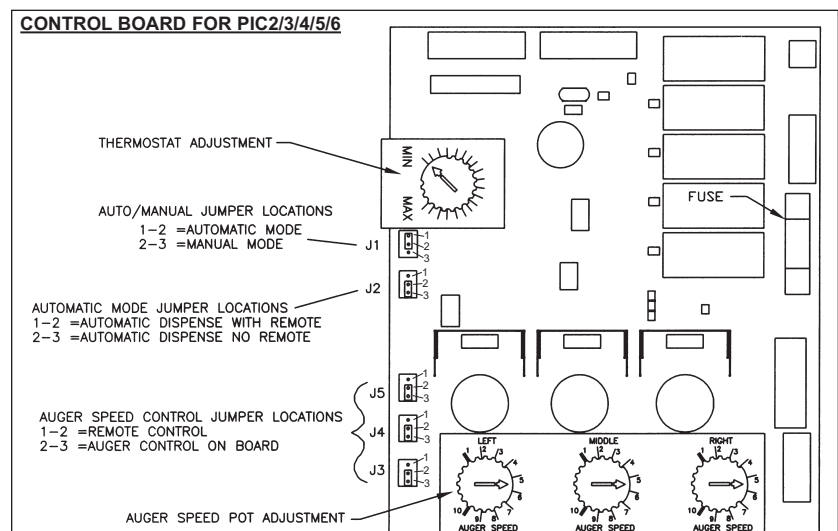

Figure B One controller used for PIC2, PIC3. One (Fig A) controller and one (Fig B) controller used for PIC4. Two controllers used for PIC43, PIC5, PIC6. Thermostat dial is not used on PIC43, PIC5, PIC6 right controller. On Right Controller: Left dial operates #4 head, middle dial operates #5 head, and right dial operates #6 head.

Drink Strength Adjustment for Model PIC3E or PIC33AE

when equipped with remote adjust knobs behind drip tray (Refer to Figure C)

1. Dispense a drink to determine if drink is too strong or too weak.
2. Remove drip tray.
3. Using a flat head screwdriver, adjust individual dispense heads by rotating appropriate adjustment knob. Clockwise rotation will result in a stronger drink and counterclockwise rotation will result in a weaker drink.
4. Dispense a drink to determine if drink strength is acceptable, repeat adjustment steps until desired drink strength is achieved.

NOTE: Water flow rate is factory preset at approximately 24mL (0.80 ounces) per second.

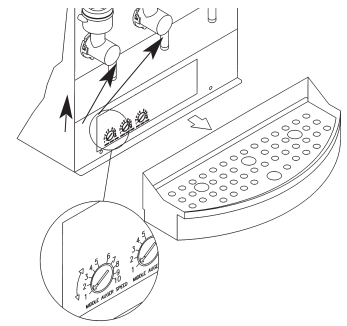

Figure C

Drink Strength Adjustment for Model PIC2J & PIC3J (Refer to Figure D)

Tool required: #2 Flat Head screwdriver

1. Dispense a drink to determine if drink is too strong, weak or if portion size is correct.
2. Turn off power to machine at power switch.
3. Drink strength and portion size controls will be found behind the drain tray. (Refer to Figure D) For portion size adjustment, turn dial clockwise to increase dispense volume. To decrease volume turn dial counterclockwise. For drink strength adjustment turn dial clockwise to increase drink strength. To decrease strength turn dial counterclockwise. Turn on power to machine and dispense a drink to determine if drink strength or portion is acceptable. If drink strength or portion is not acceptable, turn off power to machine and repeat adjustment steps until desired drink strength or portion is achieved.

Note: Clockwise rotation will result in a stronger drink and counterclockwise will result in a weaker drink.

Note: Water flow rate is factory preset at approximately 0.80 ounces per second.

* To adjust flow rate, remove left side upper panel. Use flat head screwdriver and turn knob on respective dump valve.

WARNING: Do not adjust flow rate above the factory setting to prevent funnel overflow.

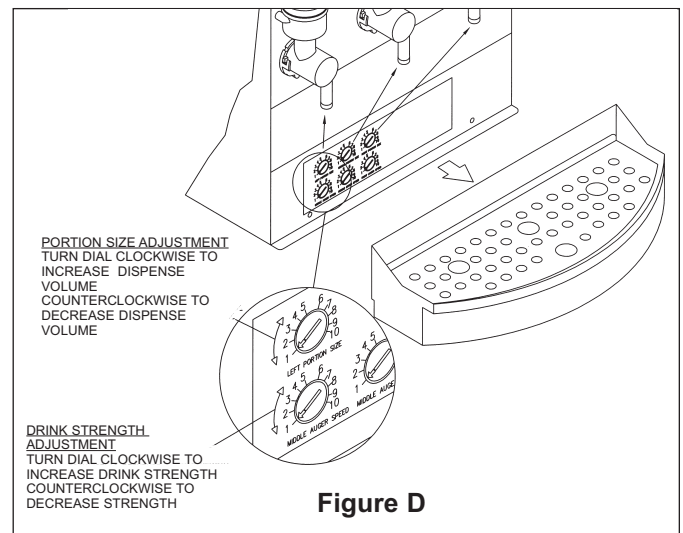

Figure D

Cleaning

CAUTION: When cleaning the unit, do not use cleansers, liquid bleach, powders or any other substance that contains chlorine. These products promote corrosion of stainless steel and plastic parts. Use of these products will void the warranty.

DAILY

1. Empty the drip pan as needed and wash daily in a solution of dish detergent.
2. Rinse out the whipper chambers by placing the rinse switch (located on the right of the dispensing valves when the door is open) in the "ON" position. Dispense one to two cups until the water is clean. Short bursts of dispensing may also help clean the chambers more effectively. When completed, return the rinse switch to the "OFF" position.
3. Remove the hoppers and refill with product.

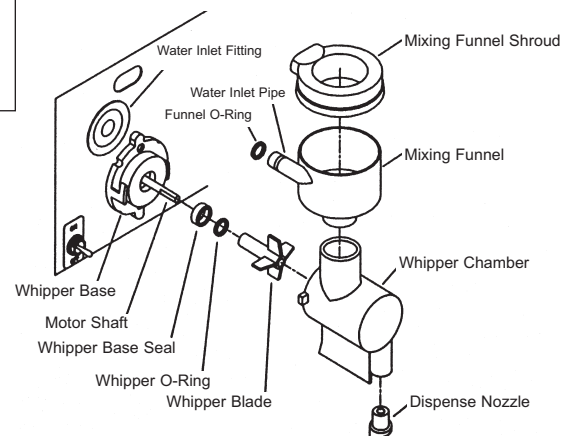

Figure E

WEEKLY

Removing and Cleaning the Chambers

1. Open the door and remove the mixing funnel shroud by pulling forward while turning 1/4 turn to the right. Lift off and remove.
2. Remove the mixing funnel by lifting the neck of the funnel out of the whipper chamber, then tilt counterclockwise. With one hand on the water inlet fitting on the back panel, pull the funnel out of the white ring.
3. Remove the whipper chamber by rotating it 1/8 of a turn clockwise, then pull to remove.
4. Remove dispense nozzle from whipper chamber by pulling it apart.
5. Remove the whipper blade by grasping the whipper blade with two fingers and firmly pulling to remove.
6. Remove the o-ring on the whipper shaft near the whipper and wipe the motor shaft with a clean towel.
7. All parts in contact with food must be washed, rinsed, sanitized and air-dried.

 **CAUTION: Do not wash parts in dishwasher. Dishwashers will cause damage to parts.**

To Reassemble

1. Replace the o-ring onto the whipper shaft.
2. Replace the whipper blade by aligning the flat side inside the blade with the flat side of the motor shaft. Push blade firmly onto shaft.
3. Press dispense nozzle into whipper chamber.
4. Replace the whipper chamber by positioning the medium sized opening up and tilting 1/8 of a turn clockwise. Put the whipper chamber over the whipper blade and turn counterclockwise until it locks into place.
5. Replace the mixing funnel by positioning the large opening up and tilting it slightly counterclockwise. Lubricate the o-ring on the water inlet pipe with a film of food grade lubricant. Insert the water inlet pipe into the water inlet fitting on the back panel, then rotate the funnel to the right until the neck of the funnel seats inside the whipper chamber opening.
6. Replace the shroud by placing it on the mixing funnel with the opening to the right. Turn the shroud to the left until the opening in the shroud rests inside the opening in the back panel.
7. If shroud doesn't rest inside the opening on the front panel, push in or lift up on the funnel.

Disassembling & Cleaning the Hoppers (PIC 1/2/3/5/6)

IMPORTANT: Do not wash hopper without first disassembling.

1. Open the door and rotate the dispense elbow on the hopper to the "UP" position to prevent spillage. (Figure F)
2. Remove the hopper from the cabinet.
3. Remove the hopper cover and empty hopper contents.
4. Pull off the elbow.
5. Remove the auger pinwheel by pulling it forward while stretching out the sides of the hopper. (Figure G)
6. Remove the drivelinek and washer at the rear of the hopper by holding the auger spring with one hand at the front of the hopper while turning the drivelinek clockwise with the other hand. (Figure H)
7. Remove the auger spring and auger spring drive shaft by pulling them out through the lower front opening of the hopper.
8. Remove the palnut at the rear of the hopper by turning it counterclockwise, then remove the drive shaft bearing from the inside of the hopper.
9. All parts in contact with food must be washed, rinsed, sanitized and air-dried.

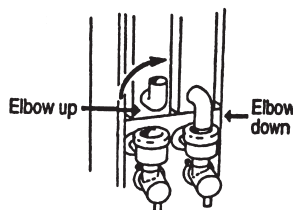

Figure F

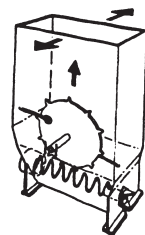

Figure G

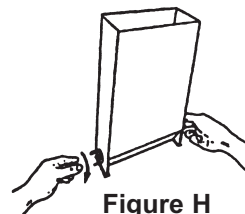

Figure H

WEEKLY (cont.)

Reassembling the Hoppers (PIC 1/2/3/5/6) (Refer to Figure I)

IMPORTANT: All components must be completely dry prior to reassembly.

1. Place the drive shaft bearing inside the hopper with the threads going through the hole in the rear of the hopper.
2. Secure the bearing by attaching the palnut to the bearing at the outside rear hopper opening. Tighten using only your fingers. Use one hand inside the hopper to push the bearing outward while turning the palnut clockwise.
3. Install the auger spring drive shaft and the auger spring by inserting the flat end of the spring into the hole in the auger drive shaft.
4. Insert assembly into the lower front hopper opening, making sure the threaded end of the auger spring drive shaft completely inserts into the drive shaft bearing in the rear of the hopper. The drive shaft bearing threads should be accessible from the outside rear of the hopper.
5. Place the washer over the drive shaft bearing threads followed by securing the drivelinek onto the drive shaft bearing by turning counterclockwise. Secure the auger spring with one hand while attaching the drivelinek with the other.
6. Replace the auger pinwheel making sure the pins are securely positioned inside the locator holes in the hopper.
7. Replace the dispense elbow in the "UP" position.
8. Fill the hopper with product and replace the cover.
9. Reinstall the hopper into the machine; making sure it is properly positioned inside the notches under the hopper.
10. Turn the elbow down toward the mixing funnel, keeping it lined up over the funnel opening.

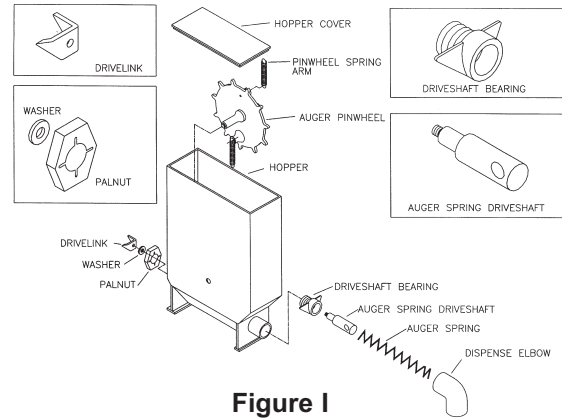

Disassembling & Cleaning the Hoppers (PIC 4)

IMPORTANT: Do not wash hopper without first disassembling.

1. Open the door and rotate the dispense elbow on the hopper to the "UP" position to prevent spillage.
2. Remove the hopper from the cabinet.
3. Remove the hopper cover and empty hopper contents.
4. Pull off the elbow.
5. Pull off hopper base.
6. Remove the auger pinwheel by pulling it forward while stretching out the sides of the hopper (thin hopper only).
*See below for wide hopper.
7. Remove the coupling at the rear of the hopper by holding the auger spring with one hand at the front of the hopper while turning the coupling clockwise with the other hand.
8. Remove the auger with o-ring by pulling them out through the lower front opening of the hopper.
9. Remove the nuts at the front and rear of the hopper by turning counterclockwise, then remove the bearings from the inside of the hopper.
10. All parts in contact with food must be washed, rinsed, sanitized and air dried.

* For wide hoppers: Remove wing nut and flat washer on outside of hopper and remove pinwheel assembly (gear with spring and pinwheel with 2 springs)

Weekly Cleaning (cont.)

Reassembling the Hoppers (PIC 4)

IMPORTANT: All components must be completely dry prior to reassembly.

1. Place the bearings inside the hopper in proper position.
2. Secure the bearings by attaching the nuts to the bearings at the outside rear hopper opening. Tighten using only your fingers.
3. Insert auger into the lower front hopper opening, making sure the threaded end of the auger spring drive shaft completely inserts into the rear bearing in the rear of the hopper. The auger threads should be accessible from the outside rear of the hopper.
4. Secure the coupling onto the auger by turning counterclockwise. Secure the auger with one hand while attaching the coupling with the other.
5. Replace the auger pinwheel making sure the pins are securely positioned inside the locator holes in the hopper (this hopper only). * See below for wide hopper. For either hopper, turn coupling and make sure pinwheel is properly installed and turns freely.
6. Replace the dispense elbow in the "UP" position.
7. Fill the hopper with product and replace the cover.
8. Reinstall the hopper into the machine; making sure it is properly aligned.
9. Turn the elbow down toward the mixing funnel, keeping it lined up over the funnel opening.

* For wide hopper: Replace pinwheel assembly by inserting gear through the pinwheel and inserting threads through the hopper wall. Insert flat washer on outside and finger-tighten wing nut securely.

Cleaning the Steam Plenum Tray (PIC 2/3/4/5/6 only) (Refer to Figure L)

⚠ CAUTION: Do not pour liquid into tray. Failure to comply will damage the dispenser and void the warranty.

1. Rotate dispense elbows on the hoppers to the "up" position and remove hoppers from machine.
2. Remove cover plate inside machine cabinet, located below hoppers.
3. Using a damp towel, wipe powder build up from inside steam plenum tray.
4. Replace cover plate.
5. Replace hoppers and turn elbows down to the dispense position.

Quarterly Cleaning

Cleaning the Steam Recovery Plenum Tray

⚠ WARNING: Risk of electric shock; Disconnect from power before servicing!

1. Remove the side access panel (Refer to figure K)
2. Disconnect the flexible vent tube attached to the recovery tray.
3. Remove the two screws which fasten the recovery tray to the sheetmetal enclosure and remove the recovery tray through the side access hole.
4. Remove the back access plate (refer to figure L). Disconnect and remove the flexible vent tube from the blower housing. Carefully remove the flexible vent tube from the machine's cabinet.
5. Wash, rinse, sanitize, and air dry the recovery tray and hose. Note: A long soft bristle brush or small cloth towel may be used to clean the internal passage of the flexible vent tube by pushing it through the tube. Rinse, sanitize and air dry the tube.
6. Reassemble the parts in reverse order.

NOTE: PIC 5 and PIC 6 contain two ports on the plenum, three flexible tubes and a barbed tee.

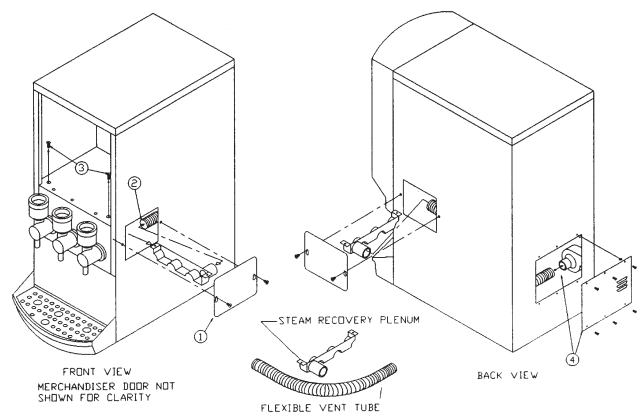

Figure J

Figure K

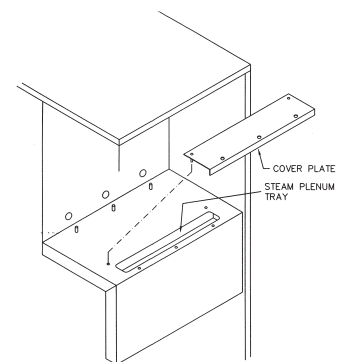

Figure L

PIC Preventative Maintenance Checklist (Every 6 to 12 months)

A preventative maintenance visit should be performed every 6 to 12 months, depending on usage. The following procedures should be performed during a preventative maintenance visit.

Parts Required: One PM parts kit (PIC1 - Qty1 - 62707, PIC2 - Qty2 - 62707 or Qty1 - 60933, PIC3 - Qty1 - 60933, PIC4 - Qty1 - 60933 and Qty1 - 62707, PIC5 - Qty2 - 60933, PIC6 - Qty2 - 60933).

Tools Required: 11/32 nut driver, needle nose pliers, phillips head screwdriver, food grade lubricant.

The following procedures should be performed by a qualified service technician.



WARNING - Risk of electric shock and burns. Disconnect power before servicing. Use care in handling hot liquids.

1. Document model and serial number of equipment above.
2. Disconnect unit from power supply and turn power off. Then remove all access panels.
3. Shut off the water supply valve to the machine.
4. Open front door of unit and remove product hoppers. Clean hoppers following procedures on the decal on panel behind hoppers or as stated in instruction manual.
5. Remove the plenum chamber access panel, if so equipped (located below hoppers on newer units). Wipe out exposed plenum.
6. Locate the tank drain hose. It is located behind the bottom access panel. It is a white silicone tubing that has a 3/8" stainless steel barb plug and a black 5/8" hose clamp on it.
7. PIC 1, 2, 3, and 4: Using a 5 gallon, heat resistant container, route the drain hose into the container.
PIC 5 and 6 contain over 5 gallons of hot water and require a minimum 6 gallon heat resistant container.
Remove the clamp, pinch the tube and remove the plug. Drain all of the water out of the tank into the container (about 3.5 gallons). Warning: the water from the tank is very hot (180°F plus). May cause burns and/or personal injury. Hot water may splash. Do not attempt to stop flow of hot water once it begins flowing through drain hose. Replace the drain hose plug and secure the clamp back onto the drain hose. Place the drain hose back inside the machine, to its original location. Carefully empty the drain bucket. Do not refill the unit at this time. Delime tank if needed.
8. Remove the mixing funnel shroud and mixing funnel from each chamber. Remove and discard the o-ring on the mixing funnel. Set the shroud and funnel aside.
9. Remove each whipper chamber and whipper blade. Check for wear and replace if necessary. Then remove and discard the small whipper shaft o-rings from each dispense head.
10. Remove the two screws from each whipper base and save the screws. Discard the old whipper base and slinger washer, and replace with the new parts in the PM kit.
11. Clean the whipper motor shaft and clean all dried product in this area under where the whipper base was located.
12. Install the new slinger washer onto the whipper motor shaft, and up to hopper mounting bracket.
13. Lubricate inside of whipper base with a food grade lubricant. Then install whipper base over the whipper motor shaft and **check alignment of holes. If alignment is off, rotate base 180° to make sure holes line up.** Hold base securely, and carefully tighten mounting screws.
14. Check whipper motor shaft to ensure it can turn freely using fingers. If shaft is hard to turn, remove screws, rotate base 180°, and re-tighten.
15. Install the new, red, small o-rings, along with the whipper blades, and whipper chambers. Clean the funnel shrouds and funnels. Install each new funnel o-ring and lubricate. Then install funnel and shroud. When complete, put the plenum chamber access panel back in place, if so equipped.
16. Remove plenum through side access hole and remove the plenum hose(s) from the blower to the plenum chamber. Clean the plenum and either clean or replace the hose(s) (part# 61123, not in kit). Re-install clean parts.
17. Remove the dump valves located behind side access panels, by loosening the dump valve bracket nuts with the 11/32 nut driver and lifting bracket up. Then pull dump valve from grommet and then remove the grommets from the tank with needle nose pliers and discard. Then remove the o-rings from the dump valves and discard. Replace with new tank grommets and new o-rings for each valve. Re-install the dump valves and secure back onto the tank. Tighten nuts on dump valve bracket.
18. Locate power supply and verify proper electrical supply to unit.
19. Find the water supply line. Turn on water supply, and verify adequate water flow.
20. Turn power supply back on. Then turn main power switch to "on".
21. Verify water tank in unit is filling. After the tank is full, verify that the heating cycle has started.
22. Allow unit to fill and shut off. Check around dump valves and any tubing for signs of water leaks.
23. Replace all access panels and reinstall hoppers inside the unit. Verify nut on back of hopper is secure.
24. Verify each dispense head is operating properly and that the settings are correct. Adjust if necessary.
25. Check for proper product temperature and check mix ration for proper setting, and adjust if necessary.
26. Review proper care, cleaning and maintenance procedures with store personnel.

Service

Changing the Lightbulb on Models With a Backlit Merchandiser (PIC 1/2/3/4/5/6)

(Refer to Figure M) (Refer to serial tag to verify model number of your machine)

⚠ WARNING: Disconnect machine from branch electrical supply before changing the lightbulb.

NOTE: PIC2/3/4 uses a F8T5 12" 8 watt replacement bulb. PIC5/6 uses a 22W circular bulb.

1. All: Remove the front merchandiser photo and cover by grasping the edges of the merchandiser.
2. PIC1: Lift bulb out of socket vertically.
PIC 2/3/4: Remove the old lightbulb by gently turning the lightbulb 1/4 turn to the left and pulling the bulb from the socket.
PIC5/6: Disconnect cable from bulb and pull bulb from holder.
3. PIC2/3/4: Install the new bulb by lining up the pins on either end of the bulb parallel with the socket opening.
4. PIC2/3/4: Gently insert both ends of the bulb into the socket and turn the bulb 1/4 turn to the right until the bulb locks into place.
5. All: Replace the merchandiser photo and cover.

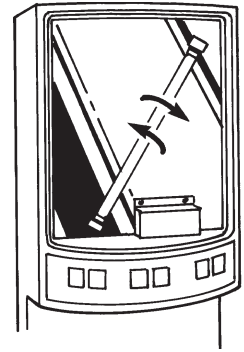

Figure M

To Prepare for Shipment

Important: Always completely empty water tank and **POWDER HOPPERS** prior to shipping unit. (See draining the tank and cleaning the hoppers sections)

NEVER SHIP UNIT WITH POWDER IN HOPPER - THIS WILL CAUSE IRREPARABLE DAMAGE.

Draining the Tank (PIC 2/3/4)

Always empty the tank before shipping.

NOTE: PIC 1 contains 2 gallons of hot water.
PIC 2, PIC 3 and PIC 4 contain 3-1/2 gallons of hot water.
PIC 5 and PIC 6 contain 5-1/2 gallons of hot water.

⚠ WARNING: Draining of tank should be performed by a qualified service technician. The tank contains very hot water. May cause severe burns.

1. Prepare a heat resistant container to drain the tank water into.
2. Unplug the machine.
3. Remove the drain tray and front access panel. (Figure N)
4. Locate the silicone drain hose on the left side wall. Put the end of the drain hose into the container. Secure the end of the drain hose (i.e. with tape) into the container. (Figure O)
5. Remove the hose clamp and plug. (Figure P)
6. Allow the tank to drain completely.

NOTE: It may be necessary to pinch the hose and stop the water before container is full. Carefully re-install plug, then empty container. Repeat steps 4-6 to completely drain tank.



Figure N



Figure O



Figure P

Draining the Tank (PIC 2/3/4) (cont.)

7. Once the tank is empty, securely replace the plug and clamp on the end of the hose. Reposition the drain hose inside the hose clip on the left side wall.
8. Reassemble the front access panel and drain tray.

Purging Machine of All Water for Shipment in Cold Areas

WARNING: This procedure should be performed by a qualified service technician.

1. Turn the power switch to the "OFF" position.
2. Drain the water tank (refer to instructions on page 12). Do not replace the drain hose plug and clamp until further instructed.
3. Turn the power switch to the "ON" position. The ready light should turn itself "ON" within 12 seconds. The 12 second delay signals that the heating element has been disabled due to the lack of water in the tank after it is drained.

IMPORTANT: If the ready light does not turn itself "ON" within 12 seconds, turn the power "OFF" to avoid burning out the heating element.

4. Listen for the inlet valve to energize. To purge the inlet valve and water inlet tube, apply 10-20 psi compressed air to the inlet valve connection for 10 to 20 seconds while the inlet valve is energized.

NOTE: Do not energize the inlet valve for more than 5 minutes at a time. Otherwise, the watchdog timer will disable the inlet valve. If this occurs, reset the machine by flipping the power switch "OFF" then "ON".

5. After the inlet valve and water inlet tube are purged, purge the dump valves and dispense lines. While applying 10-20 psi compressed air to the inlet valve connection, press and hold each dispense button for 1-2 seconds.
6. Turn the power switch to the "OFF" position. Replace the drain hose plug and clamp. Reposition the drain hose inside the hose clip on the left side wall.
7. Reassemble the front access panel and drain tray.

Replacing Whipper Motors on Machines Manufactured Prior to Fall 1998:

1. Left motor may be changed with 61116-01 (round motor) if you install a single pole switch (part # 61847) in place of the existing power switch.
2. Middle motor may be changed with 61116-01 directly.
3. Right motor can only be changed with 61116R (Oval (double-D) shaped motor).

Replacing Whipper Motors on Machines Manufactured After Fall 1998:

1. Place motor in mounting location, install lock washers and loosely tighten acorn nuts on motor mounting studs. Hold motor while shaft is centered inside hole then tighten nuts securely.
2. Install white slinger washer over the motor shaft and up to hopper mounting bracket.
3. Lubricate inside of whipper base then install over the motor shaft and check alignment of holes. If alignment is off, rotate base 180° to make sure holes line up. Hold base securely, and carefully tighten mounting screws.
4. Check the motor shaft to ensure it can turn freely with fingers. If shaft is still hard to turn, reposition motor and repeat.

120V Whipper Motor Replacement Kit # 62528

Quantity	Part #	Description
1	61523	Whipper Base Assembly
1	61116-01 or 61867	Motor, Whipper, 120V
1	62529	Instruction Sheet

230V Whipper Motor Replacement Kit # 62530

Quantity	Part #	Description
1	61523	Whipper Base Assembly
1	61117-01	Motor, Whipper, 230V
1	62529	Instruction Sheet

Removal of Whipper Motor(s):

1. Disconnect power.
2. Remove front and side access panels.
3. Remove chamber.
4. Remove whipper base. (Figure Q)
5. Remove motor nuts and pull motor out of slot. (Figure R, S)
6. Disconnect wire connection. (Figure T)
7. Replace motor as needed.



Figure Q

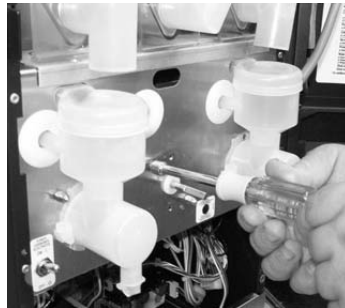

Figure R

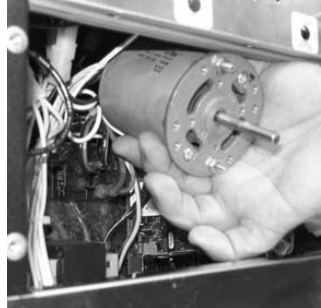

Figure S

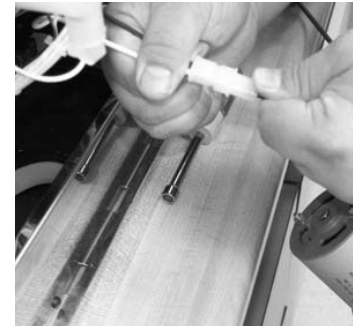

Figure T

Replacing Dump Valves, Dump Valve O-rings, and/or Tank Grommets

1. Remove the dump valves located behind side access panels, by loosening the dump valve bracket nuts with 11/32 nut driver and lifting bracket up. (Figure U, V)
2. Pull dump valve from grommet and then remove the grommets from the tank with needle nose pliers and discard. (Figure W)
3. Remove the o-rings from the dump valves and discard. Replace with new tank grommets and new o-rings for each valve. (Figure X)
4. Re-install the dump valves and secure back onto the tank.
5. Tighten nuts on dump valve bracket.

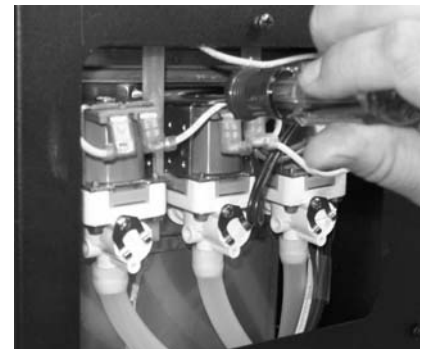

Figure U

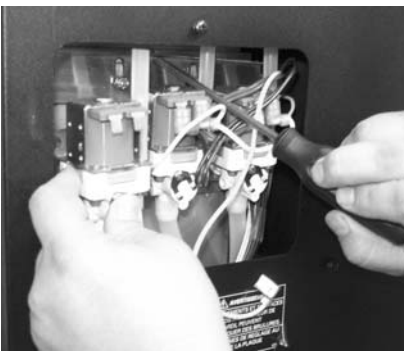

Figure V



Figure W



Figure X

Replacing Water Tank on Machines with Serial # 339304 and Lower: (Refer to Figures Y, Z, AA)

1. Switch off and unplug unit, disconnect from water supply, and drain tank completely.
2. Remove top of cabinet, left side and rear access panels.
3. Disconnect tank ground, heating element, thermal probe, water probe and hi-level thermostat wires and vent tubing in top of unit.

Replacing Water Tank on Machines with Serial # 339304 and Lower: (cont.)

4. Disconnect dump valve wiring and tubing in left access opening and remove valves.
5. Disconnect tank fill tubing from inlet valve in rear of unit.

6. Remove screws holding water tank and mounting bracket. Remove tank, bracket and old tubing
(NOTE: Do not discard dump valve tubing).

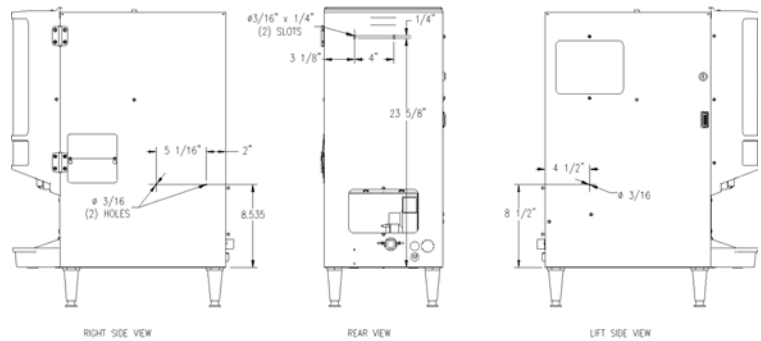

Figure Y

7. Remove heating element, thermal probe, water probe, vent fittings, and valve retaining clip from old tank. Examine to determine if these items need to be replaced. Remove and discard old hi-level thermostat and mounting bracket.
8. Drill holes in cabinet per sketch below and deburr. (Figure Y)
9. Install (3) #8-32 x 3/8" machine screws (07026-07) in new holes in sides of casing. Lower new tank retaining bracket (61845) from the top of the unit until it rests on the machine screws. Add locknuts (71261) and tighten.

NOTE: Instructions above are for units with a stainless steel casing, for units with a black powder coat casing, use black screws (61303).

10. Install new dump-valve grommets (61243) and plugs (61229) (for PIC2 only) in side of new tank (61841).
11. Install new probe grommets (71147), heating element with new hi-level thermostat (62305), mounting bracket (62238) and (2) #8-32 x 1/4" SS screws (61353), thermal probe, water probe, and vent fittings in new tank cover (61842) as shown in sketch below.

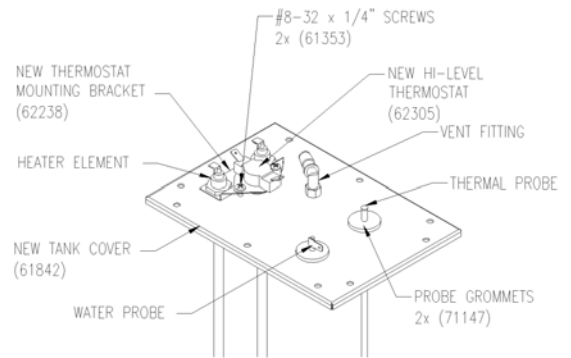

Figure Z

12. Place tank gasket (61844) over top of new tank (61841), aligning holes with studs, and lower new tank cover (61842) over studs. Bolt tightly with (10) #8-32 locknuts (71261).
13. Lower tank onto retaining bracket, feeding fill fitting in tank bottom through the hole in the bracket. Bolt tank to the back of casing with (2) lock washers (61186) and (2) #8-32 x 3/8" machine screws (07026-07) for stainless casings, or #8-32 x 3/8" black screws for black powder coat units.
14. Install new o-rings (61365) on dump valves and insert them into side of tank from the access panel in the side of the casing. Secure with valve retaining clip, reconnect all wires and dump valve tubing.

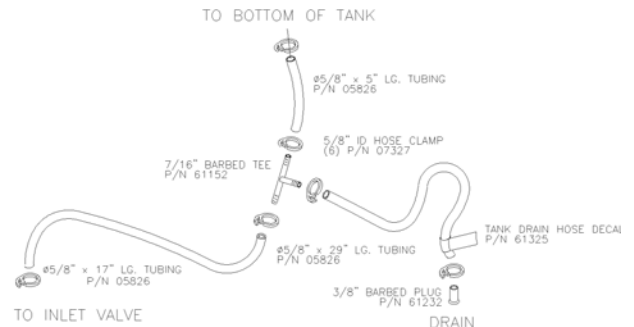

Figure AA

15. Measure and cut new 29" vent tubing (05826), connect one end to the vent fitting in the top of tank and run the other end down the side of the tank to the bottom of the unit. Reconnect all wires to tank ground, heating element, thermal probe, water probe, and hi-level thermostat.
16. Cut and install new tubing (05826) from inlet valve to tank fill fitting and drain per sketch.

NOTE: Apply tank drain hose decal (61325) to drain hose after installing and feeding drain hose through hole in control mounting bracket in bottom of the unit.

17. Replace all panels and reconnect to water and electrical supply.

Removal of Water Tank on Machines with Serial # 339305UK and Higher:

1. Disconnect power.
2. Drain tank. (see page 12)
3. Remove machine lid, rear access panel and dump valve access panel. (Figure BB)
4. Disconnect wires from tank lid components and dump valves. (Figure CC)
5. Disconnect hoses from dump valves.
6. Remove mounting screws from rear of tank. (Figure DD)
7. Disconnect drain hose from bottom of tank. (Figure EE)
8. Lift out tank and replace as needed. (Figure FF)



Figure BB



Figure CC

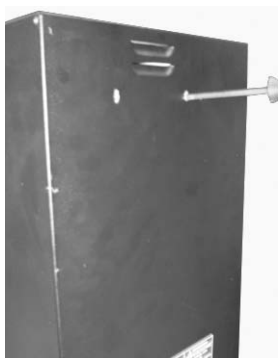

Figure DD



Figure EE



Figure FF

Removal of Inlet Valve

1. Disconnect power.
2. Drain tank. (see page 12)
3. Remove rear access panel.
4. Disconnect black hose from fan.
5. Remove two screws and lock nuts. (Figure GG)
6. Remove valve. (Figure HH)
7. Disconnect wire connection, hose clamp and hose. (Figure II)
8. Replace valve as needed.



Figure GG



Figure HH



Figure II

Removal of Thermistor

1. Disconnect power.
2. Remove machine lid. (Figure JJ)
3. Disconnect thermistor wires. (Figure KK)
4. Lift out thermistor and replace as needed. (Figure LL)
5. To replace with thermistor, add food grade lubricant. (Figure MM)



Figure JJ

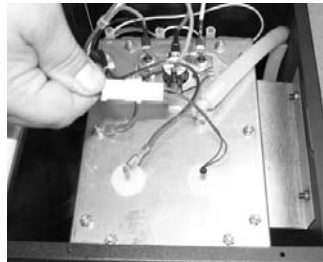

Figure KK



Figure LL



Figure MM

THERMISTOR CURVE

°C	°F	RESISTANCE (OHMS)	°C	°F	RESISTANCE (OHMS)
0	32	16325	60	140	1244
5	41	12697	65	149	1041
10	50	9951	70	158	875
15	59	7856	75	167	740
20	68	6246	80	176	628
25	77	5000	85	185	535
30	86	4028	90	194	458
35	95	3266	95	203	393
40	104	2663	100	212	339
45	113	2185	105	221	294
50	122	1802	110	230	255
55	131	1493			

Removal of Auger Motor(s)

1. Disconnect power.
2. Remove front and side access panels.
3. Remove hoppers.
4. Remove three screws and lock washers. (Figure NN)
5. Pull motor out of slot. (Figure OO)
6. Disconnect wire connection.
7. Replace motor as needed.



Figure NN

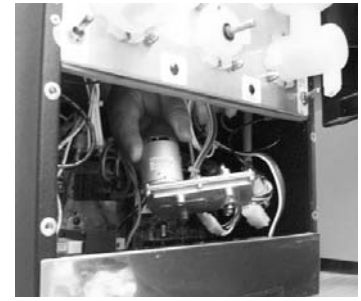

Figure OO

Removal of Blower Motor

1. Disconnect power.
2. Drain tank. (see page 12)
3. Remove rear access panel.
4. Disconnect black hose from fan.
5. Disconnect hose from inlet valve if needed.
6. Remove two screws from side.
7. Remove fan. (Figure PP)
8. Disconnect wires.
9. Replace motor as needed.

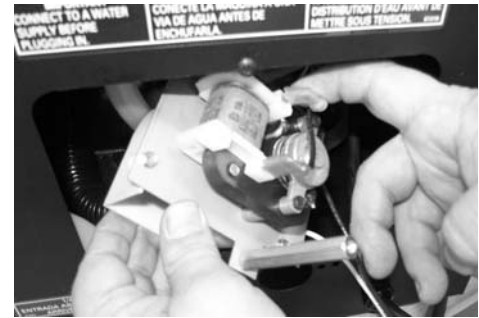

Figure PP

Removal of Controller

1. Disconnect power.
2. Remove front access panels.
3. Carefully remove connectors from controller. (Do not pull on wires.)
4. Carefully press black clips back and pull out controller. (Do not pull on controller components - pull only on green board.)
5. Carefully remove controller. (Figure QQ) (Handle controller only on edges of green board.)
6. Replace controller as needed.

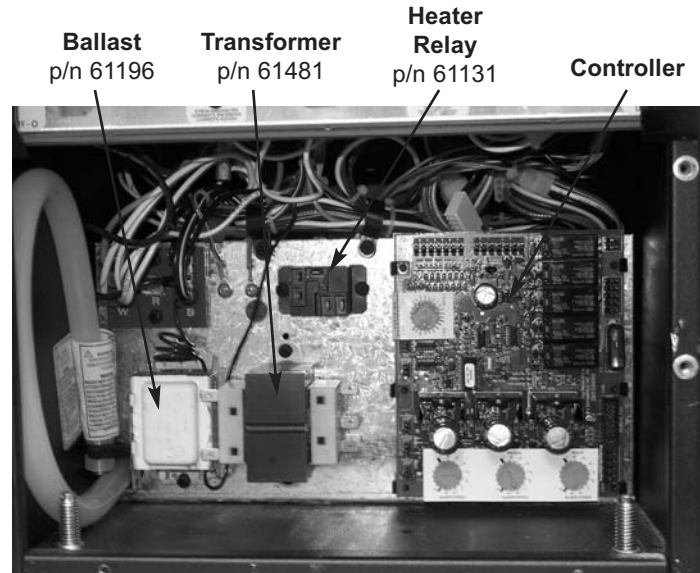

Figure QQ

Removal of Heater Relay

1. Disconnect power.
2. Remove front access panels.
3. Remove wires from relay. (Note locations of wires before removing.)
4. Remove screws and lift out relay. (Figure QQ)
5. Replace relay as needed.

Removal of Transformer

1. Disconnect power.
2. Remove front access panels.
3. Remove wires from transformer. (Note locations of wires before removing.)
4. Remove screws and lift out transformer. (Figure QQ)
5. Replace transformer as needed.

ITEM	PART NO.	DESCRIPTION
1	65063	Motor, 24VDC,30 RPM,Sol
2	100088	Motor,24VDC,145RPM,PIC4/SP
3	61618	Motor,24VDC,Auger,145 RPM
4	100089	Shaft,Gearbox,PIC4/SP
5	65047	Shaft, Componenti, Brass
6	61116-01-1	Motor, Whipper 120V
7	61334	Washer, Slinger
8	61523	Whipper Base Assy
9	63072	Plug,Whipper Base,Soluble
10	60741	O-Ring,2-014
11	61458	Blade, Whipper
12	07023-04	Screw,6-32x1/4 PH BD M/S SS
13	61339	NUT, 8-32 ACORN ALNGTD
15	61303	Screw, #8 x 3/8 black trilobe
16	61353	Screw,8-32 X 1/4" PH PN 18-8 SS
17	61250	Washer, #8 Split Lock
18	61264	Plug, 3/16" Hole

Conversion Procedure for PIC Soluble Coffee to Cappuccino and Vice-Versa

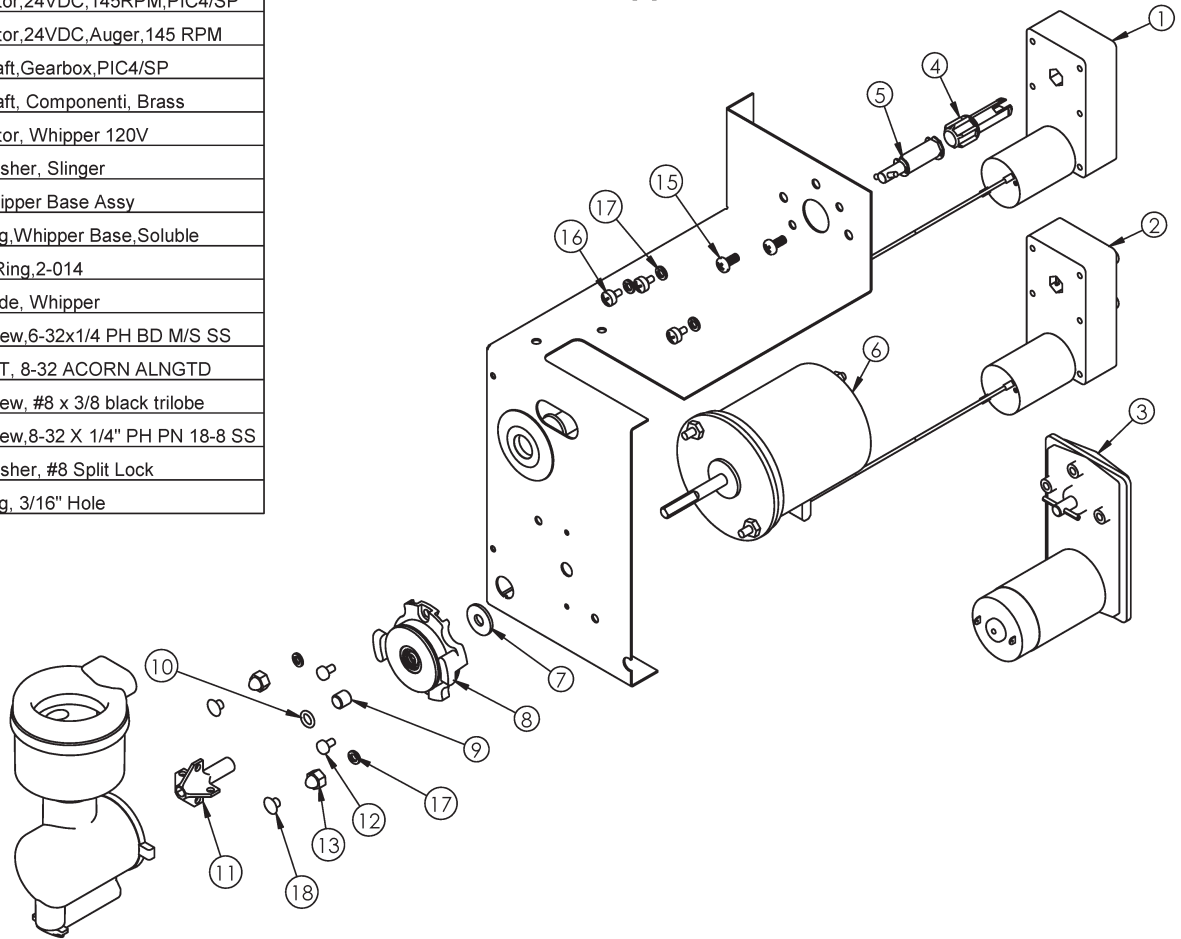

#63081, PIC2, 3, 5, 6 Conversion Procedure from Soluble Coffee to Cappuccino:

1. Remove Whipper Base #8, Base Plug #9 & Hole Plugs #18.
2. Install new Whipper Motor #6 with Acorn Nuts #13 and Lock Washers #17.
3. Install new Slinger Washer #7, Whipper Base #8, O-Ring #10, and Whipper Blade #11.
4. Remove Auger Motor #1.
5. Install New Auger Motor #3 (145rpm) and fasten with new Screws #16 and Lock Washers #17.
6. Make sure all wires are connected and secured.

#63083, PIC4 Conversion Procedure from Soluble Coffee to Cappuccino:

1. Remove Whipper Base #8, Base Plug #10 & Hole Plugs #18.
2. Install new Whipper Motor #6 with Acorn Nuts #13 and Lock Washers #17.
3. Install new Slinger Washer #7, Whipper Base #8, O-Ring #10, and Whipper Blade #11.
4. Remove Auger Motor #1 (30rpm).
5. Install New Auger Motor #2 (145rpm) with plastic Shaft #4 and fasten with 2 Screws #15.
6. Make sure all wires are connected and secured.

#63082, PIC2, 3, 5, 6 Conversion Procedure from Cappuccino to Soluble Coffee:

1. Remove and discard Whipper Motor #6, Whipper Base #8, Slinger Washer #7, O-Ring #10, and Whipper Blade #11.
2. Install new Hole Plugs #18 into whipper motor mounting holes.
3. Install new Whipper Base #8 with new Plug #9.
4. Remove Auger Motor #3.
5. Install New Auger Motor #1 (30rpm) with metal Shaft #5 and fasten with new Screws #15.
6. Make sure all wires are connected and secured... cap motor wire connector with electrical tape.

#63084, PIC4 Conversion Procedure from Cappuccino to Soluble Coffee:

1. Remove and discard Whipper Motor #6, Whipper Base #8, Slinger Washer #7, O-Ring #10, and Whipper Blade #11.
2. Install new Hole Plugs #18 into whipper motor mounting holes.
3. Install new Whipper Base #8 with new Plug #9.
4. Remove Auger Motor #2 (145rpm).
5. Install New Auger Motor #1 (30rpm) with plastic Shaft #4 and fasten with 2 Screws #15.
6. Make sure all wires are connected and secured... cap motor wire connector with electrical tape.

Troubleshooting Guide

Only a qualified service technician should perform Electrical and mechanical adjustments or repairs.
Always disconnect power before attempting any maintenance procedures.

PROBLEM	PROBABLE CAUSE	CORRECTIVE ACTION
No powder dispensed into mixing funnel	<ul style="list-style-type: none"> Rinse switch turned to "RINSE ON" position Powder hopper dispense outlet clogged No or low powder level in hopper Hopper driveline not engaged with motor Hopper elbow is not directed into the mixing funnel 	<ul style="list-style-type: none"> Flip rinse switch to "RINSE OFF" position Refer to Cleaning of Hoppers section Refill hopper Remove and reinstall hopper and ensure engagement with motor Turn down dispense elbow; line it up with mixing funnel
Machine will not dispense any product (water or powder)	<ul style="list-style-type: none"> Power turned "OFF" to machine Dispense cycle watchdog timer has tripped Faulty transformer Faulty control board 	<ul style="list-style-type: none"> Ensure power switch is in "ON" position, machine is plugged in and water is turned on Reset machine by flipping power switch "OFF" then "ON" once (the maximum run time per head is limited to 40 seconds before watchdog timer disables the dispense heads) Contact factory for assistance Contact factory for assistance
Product not whipping	<ul style="list-style-type: none"> Whipper blade broken or missing 	<ul style="list-style-type: none"> Verify blade is in place. Replace if broken or missing
Water overflows mixing funnel	<ul style="list-style-type: none"> Water flow too fast Whipper chamber outlet restricted Whipper blade broken or missing 	<ul style="list-style-type: none"> Contact factory for assistance Dump valves to be adjusted Remove obstruction Verify blade is in place. Replace if broken or missing
Drink is too weak or strong		Refer to Drink Strength Adjustment section (page 6)
Drink is too hot or cold		Refer to Thermostat Adjustment section (page 6)
No hot water from dispense head	<ul style="list-style-type: none"> Check for flashing lights on controller Water level in tank is below water probe Thermostat not adjusted Faulty heater relay Dump tube from water tank is kinked Water shorting out probe connections 	<ul style="list-style-type: none"> Refer to Controller Diagnostics section (page 20) Ensure that water supply to machine is "ON" and reset power to machine See Thermostat Adjustment section (page 6) Replace heater relay (page 18) Check tubing for obstructions Dry connections on tank
Water tank boils water	<ul style="list-style-type: none"> Check for flashing lights on controller Thermostat adjustment set too high Faulty heater relay 	<ul style="list-style-type: none"> Refer to Controller Diagnostics section (page 20) Refer to Thermostat Adjustment section (page 6) Replace heater relay (page 18)
No water dispensed from dispense nozzle	<ul style="list-style-type: none"> Water supply to machine turned "OFF" Check for flashing lights on controller Faulty dump valve 	<ul style="list-style-type: none"> Turn "ON" water supply to machine Refer to Controller Diagnostics section (page 20) Replace dump valve (page 14)
Water overflows from water tank	<ul style="list-style-type: none"> Leaky inlet water valve Faulty level probe connection Faulty level probe due to mineral build-up Inlet water pressure too high (greater than 120 psi) 	<ul style="list-style-type: none"> Replace inlet water valve Check level probe connections Replace probe Install pressure regulator to water inlet
Machine inadvertently dispenses from dispense heads	<ul style="list-style-type: none"> Wet wiring connections on harness or controller 	<ul style="list-style-type: none"> Allow connections to dry
Drink is cold and ready light is on	<ul style="list-style-type: none"> Check for flashing lights on controller 	<ul style="list-style-type: none"> Refer to Controller Diagnostics section (page 20)

Troubleshooting Guide (cont.)

Only a qualified service technician should perform Electrical and mechanical adjustments or repairs. Always disconnect power before attempting any maintenance procedures.

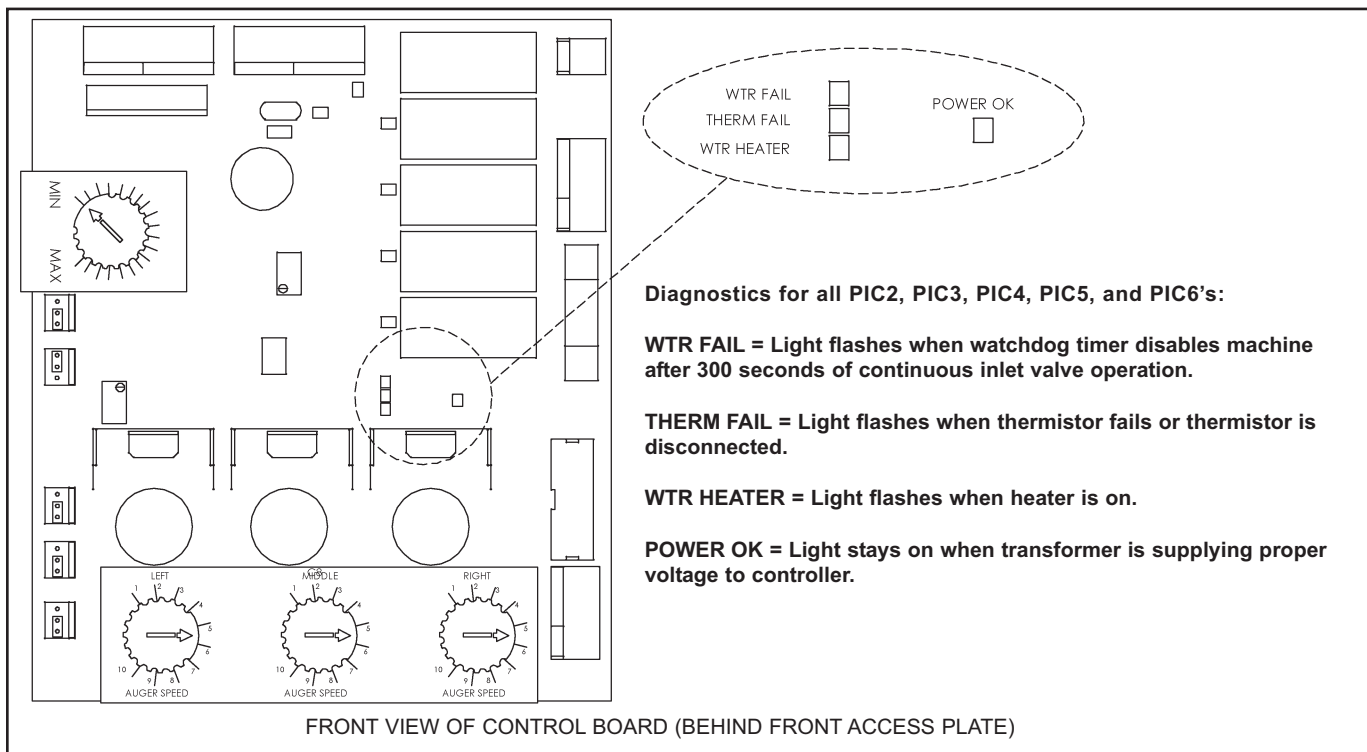

Diagnostics for all PIC2, PIC3, PIC4, PIC5, and PIC6's:

WTR FAIL = Light flashes when watchdog timer disables machine after 300 seconds of continuous inlet valve operation.

THERM FAIL = Light flashes when thermistor fails or thermistor is disconnected.

WTR HEATER = Light flashes when heater is on.

POWER OK = Light stays on when transformer is supplying proper voltage to controller.

If WTR FAIL light is flashing:

- Ensure water supply to machine is turned "on".
- Reset machine power "off" then "on".

If THERM FAIL light is flashing:

- Reset machine power "OFF" then "ON". If green ready light does not turn off after 10 seconds then:
- Check thermistor connections.
- If connected properly, replace faulty thermistor. (Mineral build-up may be the cause.)

WTR HEATER light will flash on and off when the water tank is being heated:

- Note: When green "ready" light on front of machine is "Off" WATER HEATER light should flash.
- If light works properly and machine is not heating, replace faulty heater. (Mineral build-up may be the cause.)

If POWER OK light is off:

- Make sure power switch is on and machine is plugged in.
- If switch is on, and light is off, call factory for assistance.

Note: PIC 4/5/6 - If water gets cut off to machine for 5 minutes during operation, tank water will not replenish, heater circuit will be disabled, and heads #1-3 will be disabled. Other heads will still operate. Left controller will read "WATER FAIL". What could happen is that other heads will dispense low or no water (possibly cold) and full amounts of powder.

Note: PIC 4/5/6 - "Thermistor Fail" - When the thermistor reads out of range or is disconnected, the machine shuts down the dispensing and heating. Only heads #1-3 are disabled, other heads can still operate. This can cause cold drinks to be dispensed out of the right head(s).

If you still need help, call our service department at (800) 695-4500 (USA and Canada only) or (502) 425-4776 (Monday through Friday, 8 am - 8 pm EST) or an authorized service center in your area. Please have the model and serial numbers ready so that accurate information may be given.

Prior authorization must be obtained from Grindmaster Corporation's Technical Services Department for all warranty claims.

PIC 1 Chassis Parts

(units with serial numbers beginning with "L")

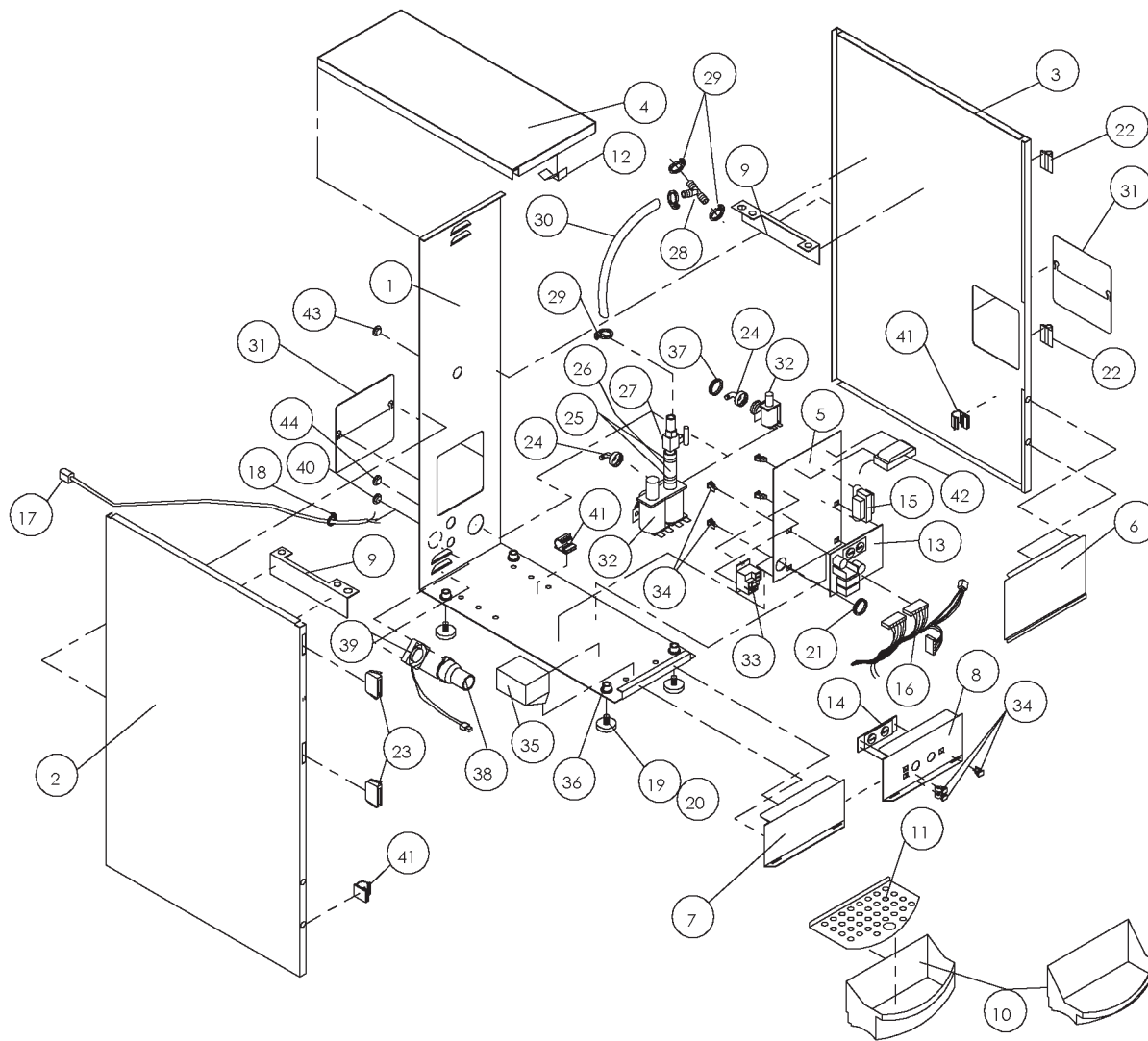

NOTE NO.	PART NUMBERS					DESCRIPTION	NOTE NO.	PART NUMBERS					DESCRIPTION	
	120 VOLT	230V "E"	100V "J"	240V "Q"	200V "J"			120 VOLT	230V "E"	100V "J"	240V "Q"	200V "J"		
1	61601	61601	61601	61601	61601	BOTTOM/BACK, POWDER COATED	21	60394	60394	60394	60394	BUSHING, 7/8 O.D. x 3/4 I.D.		
2	61624	61624	61624	61624	61624	PANEL, LEFT SIDE, POWDER COATED	22	61400	61400	61400	61400	HINGE, BLACK STAINLESS 4-LEAF		
3	61625	61625	61625	61625	61625	PANEL, RIGHT SIDE, POWDER COATED	23	61235	61235	61235	61235	CATCH, MAGNETIC SNAP-IN		
4	61607	61607	61607	61607	61607	COVER, TOP, POWDER COATED	24	61237	61237	61237	61237	FITTING, HOSE TO 1/4 FLARE		
5	61610	61610	61610	61610	61610	BRACKET, CONTROL MOUNTING	25	60550	N/A	N/A	60550	N/A	CLAMP, 11/16 STEPLESS EAR (*)	
6	61604	61604	61604	61604	61604	PANEL, UPPER SPLASH	26	61153	N/A	N/A	61153	N/A	TUBING, INNER BRAIDED, PVC (*)	
7	61613	N/A	N/A	61613	N/A	PANEL, LWR. SPLASH, STANDARD	27	61150	N/A	N/A	61150	N/A	VALVE, AMBIENT FLOW CTRL. (*)	
8	N/A	61704	61704	N/A	61704	PANEL, LWR. SPLASH, REMOTE	28	61152	N/A	N/A	61152	N/A	TEE, 7/16 x 7/16 x 7/16 (*)	
9	61602	61602	61602	61602	61602	BRACKET, TANK MOUNTING	29	07327	N/A	N/A	07327	N/A	CLAMP, 5/8 I.D. HOSE (*)	
10	61706	61706	61706	61706	61706	TRAY, DRAIN, PLASTIC	30	71155	N/A	N/A	71155	N/A	TUBING, 5/16 I.D. SILICONE (*)	
	62335	62335	62335	62335	62335	TRAY, DRAIN PLASTIC LOW	31	61438	61438	61438	61438	61438	PANEL, PLENUM ACCESS	
11	61617	61617	61617	61617	61617	GRID, DRAIN, PLASTIC	32	63493	61105	63493	63493	61105	VALVE, INLET 1.2 GPM	
12	61217	61217	61217	61217	61217	SPRING, HOPPER RETAINING		71650	71650	71650	71650	71650	REBUILD KIT, INLET VALVE	
13	61632	(61632)	(61632)	61632	(61632)	CONTROLLER, PIC1 (MANUAL)(OPT. OVERSEAS)		61149	N/A	N/A	61149	N/A	VALVE, INLET W/DUAL OUT. (*)	
	N/A	61737	61737	N/A	61737	CONTROLLER, PIC1 (AUTO/ANALOG)	33	61131	61131	61131	61131	61131	RELAY, HEATER	
	(61739)	N/A	N/A	(61739)	N/A	CONTROLLER, PIC1 (AUTO/DIGITAL; OPT.)	34	61266	61266	61266	61266	61266	STANDOFF, PCB MOUNT	
14	N/A	61643	61643	N/A	61643	CTRL. BOARD, REMOTE (ANALOG OPT.)	35	N/A	61170	N/A	N/A	N/A	N/A	FILTER, EMI, 230V
15	61481	61470	61482	61481	61482	TRANSFORMER, CONTROL BOARD	36	60380	60380	60380	60380	60380	RIVNUT, 3/8-16	
16	61708	61712	61708	61708	61708	HARNES, CONTROL BOARD	37	N/A	61514	N/A	N/A	N/A	N/A	O-RING, 0.906 I.D. x .210
17	61530	61453	02890	60200	61736	POWER CORD	38	61633	61633	61633	61633	61633	PLENUM/FAN MOUNT	
18	61479	86071	86071	N/A	86071	STRAIN RELIEF, HEYCO	39	61635	61635	61635	61635	61635	FAN, 24VDC, 40mm	
	N/A	N/A	N/A	07920	N/A	STRAIN RELIEF, METAL ROMEX	40	71138	N/A	N/A	71138	N/A	N/A	PLUG, STR. RELIEF, 5/8"
19	61344	61344	61344	61344	61344	PAD, LEVELLER FOOT	41	71160	71160	71160	71160	71160	CLIP, HOSE W/ADHESIVE	
20	61343	61343	61343	61343	61343	BOLT, LEVELLER FOOT	42	61196	61468	61166	61196	61169	BALLAST (LIT MERCH. OPTION)	
							43	61743	61743	61743	61743	61743	PLUG, HOLE, 3/4" HEYCO	
							44	N/A	61751	61751	61751	61751	PLUG, STR. RELIEF, 3/4"	

(*) = USED W. AMBIENT TEMP. OPTION

PIC 1 Hopper Bracket

(units with serial numbers beginning with "L")

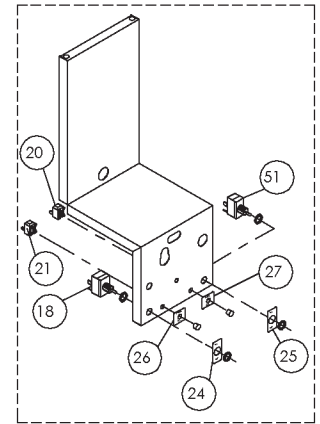
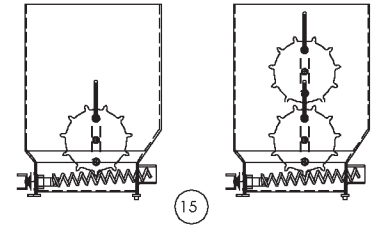
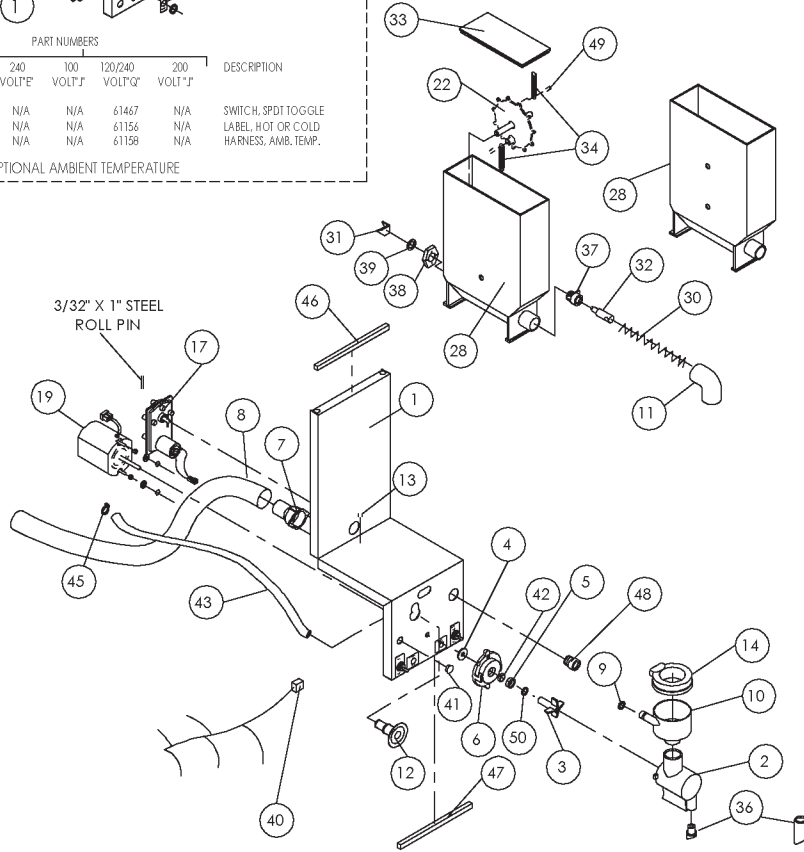
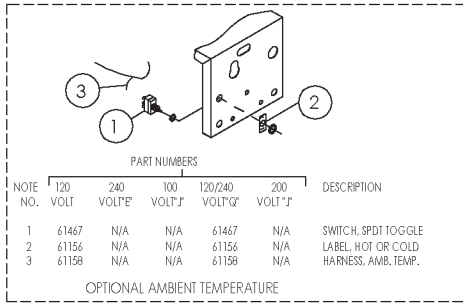

PART NUMBERS						DESCRIPTION
NOTE NO.	120 VOLT	230V "E"	100V "J"	120/240V "Q"	200V "U"	
1	61603	61603	61603	61603	61603	BRACKET, HOPPER MOUNT.
2	62395	62395	62395	62395	62395	CHAMBER, WHIPPER
3	61458	61458	61458	61458	61458	BLADE, WHIPPER FOUR
4	61334	61334	61334	61334	61334	WASHER, SLINGER
5	61459	61459	61459	61459	61459	SEAL, LIP, 1/4 ID x 0.618 OD
6	61456	61456	61456	61456	61456	BASE, WHIPPER, SELF-LOCATING
7	61633	61633	61633	61633	61633	PLENUM, STEAM RECOVERY
8	61123	61123	61123	61123	61123	TUBING, 1 1/4" ID FLEXIBLE
9	61127	61127	61127	61127	61127	O-RING, 3/8 ID x 1/2 OD
10	61221	61221	61221	61221	61221	FUNNEL
11	61223	61223	61223	61223	61223	ELBOW, HOPPER
12	61226	61226	61226	61226	61226	FITTING, FUNNLL, QUIK CNCT.
13	61228	61228	61228	61228	61228	SPACER
14	61255	61255	61255	61255	61255	SHROUD, STEAM RECOVERY
15	61372	61372	61372	61372	61372	HOPPER, ASSY 5LB .531 AUG
	61442	61442	61442	61442	61442	HOPPER, ASSY 5LB .718 AUG
	61837	61837	61837	61837	61837	HOPPER, DUAL PINW .531
	61490	61490	61490	61490	61490	HOPPER, DUAL PINW .718
17	61618	61618	61618	61618	61618	MOTOR, 12VDC AUGER
18	61847	61466	61847	61466	61466	SWITCH, TOGGLE, 16A DPST
19	61116	61117	61116	61116	61117	MOTOR, WHIPPER
20	62436	61125	61168	62436	61125	LAMP, GREEN
21	05096	70271	61167	05096	70271	LAMP, RED
22	61316	61316	61316	61316	61316	AGITATOR, PINWHEEL
24	61241	61241	61241	61241	61241	DECAL, POWER ON/OFF
25	61242	61242	61242	61242	61242	DECAL, RINSE ON/OFF
26	61247	61247	61247	61247	61247	DECAL, POWER ON

PART NUMBERS						DESCRIPTION
NOTE NO.	120 VOLT	230V "E"	100V "J"	120/240V "Q"	200V "U"	
27	61248	61248	61248	61248	61248	DECAL, READY
28	61222	61222	61222	61222	61222	HOPPER, 5lb.
	61489	61489	61489	61489	61489	HOPPER, 5lb. DUAL PINW
30	61224	61224	61224	61224	61224	AUGER, .531 PITCH
	61302	61302	61302	61302	61302	AUGER, .718 PITCH
31	61225	61225	61225	61225	61225	LINK, AUGER DRIVE
32	61230	61230	61230	61230	61230	DRIVESHAFT, AUGER SPRING
33	61315	61315	61315	61315	61315	COVER, 5lb. HOPPER
34	61313	61313	61313	61313	61313	SPRING, PINWHL. AGITR.
36	61461	61461	61461	61461	61461	BUTTON, RESTRICTOR ANGLED
	62494	62494	62494	62494	62494	SPOUT, PSD LONGER
37	61246	61246	61246	61246	61246	BEARING, DRIVESHAFT
38	61314	61314	61314	61314	61314	PALNUT, 5/8-11 UNC.
39	07301-04	07301-04	07301-04	07301-04	07301-04	WASHER, FLAT #10 SAE S.S.
40	61709	61709	61709	61709	61709	HARNES, HOPPER BRACKET
41	61157	61157	61157	61157	61157	PLUG, AMBIENT SWITCH HOLE
42	61460	61460	61460	61460	61460	BEARING, 1/4 ID x 5/16 OD
43	71155	71155	71155	71155	71155	TUBING, 5/16 ID 3/32 WALL
45	N/A	07327	N/A	N/A	N/A	CLAMP, 5/8 ID HOSE
46	61734	61734	61734	61734	61734	SEAL, CLOSED CELL FOAM
47	61735	61735	61735	61735	61735	SEAL, HOPPER BKT.
48	61480	61480	61480	61480	61480	STRAIN RELIEF, HEYCO 1240
49	61437	61437	61437	61437	61437	SCREW, 6-32 KNURL
50	60741	60741	60741	60741	60741	O-RING, 0.239 x 0.070
51	61847	61847	61847	61847	61847	SWITCH, SPST RINSE

PIC 1 Door Assembly

(units with serial numbers beginning with "L")

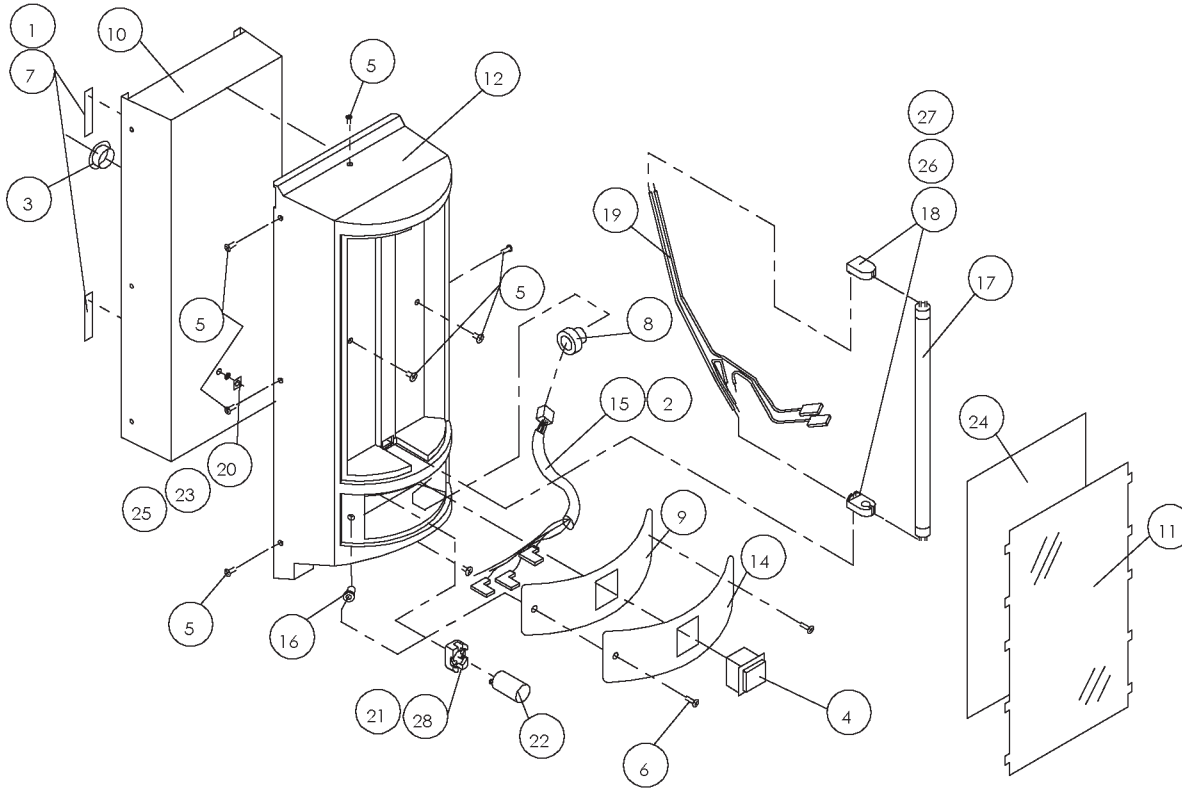

PART NUMBERS

NOTE NO.	PART NUMBERS					DESCRIPTION
	120 VOLT	240 VOLT "E"	100 VOLT "J"	120/240 VOLT "Q"	200 VOLT "J"	
1	07348-01	07348-01	07348-01	07348-01	07348-01	RIVET, POP
2	60080	60080	60080	60080	60080	CLAMP, 5/8 NYLON
3	60394	60394	60394	60394	60394	BUSHING, SNAP, 7/8"
4	61725	61725	61725	61725	61725	SWITCH, BREW DISPENSE
5	61303	61303	61303	61303	61303	SCREW, #8 x 3/8 TAPTITE
6	61304	61304	61304	61304	61304	SCREW, 6-32 x 1/2
7	61424	61424	61424	61424	61424	PLATE, STRIKER
8	61479	61479	61479	61479	61479	STRAIN RELIEF 3/4"
9	61609	61609	61609	61609	61609	PANEL, DISPENSE SWITCH
10	61616	61616	61616	61616	61616	BRACKET, MERCH. REINF.
11	61619	61619	61619	61619	61619	COVER, GRAPHICS
12	61622	61622	61622	61622	61622	MERCHANDISER, PLASTIC
14	61707	61745	61745	61707	61745	DECAL, SWITCHPANEL
15	61711	61711	61711	61711	61711	HARNES, DOOR INTERCONNECT
16	60381	60381	60381	60381	60381	RIVNUT, 6-32 AVK
17	61118	61118	61118	61118	61118	LAMP, FLUORESCENT
18	61513	61513	61513	61513	61513	SOCKET, FLUOR., MINI BI-PIN
19	61136	61136	61136	61136	61136	HARNES, LAMP
20	61187	61187	61187	61187	61187	WASHER, #8 LOCK
21	62522	62522	62522	62522	62522	SCREW, 4-36 x 3/8
22	61194	61194	61194	61194	61194	STARTER
23	61272	61272	61272	61272	61272	SCREW, #8 x 3/8 GREEN
24	61777	61777	61777	61777	61777	GRAPHIC, BACK-LIT, MERCH.
25	70635	70635	70635	70635	70635	TERMINAL, 1/4 MTAB
26	07023-04	07023-04	07023-04	07023-04	07023-04	SCREW, 6-32 x 1/4
27	07206-06	07206-06	07206-06	07206-06	07206-06	NUT, 6-32
28	62521	62521	62521	62521	62521	BASE, STARTER

PIC 1 Tank Assembly

(units with serial numbers beginning with "L" or "T")

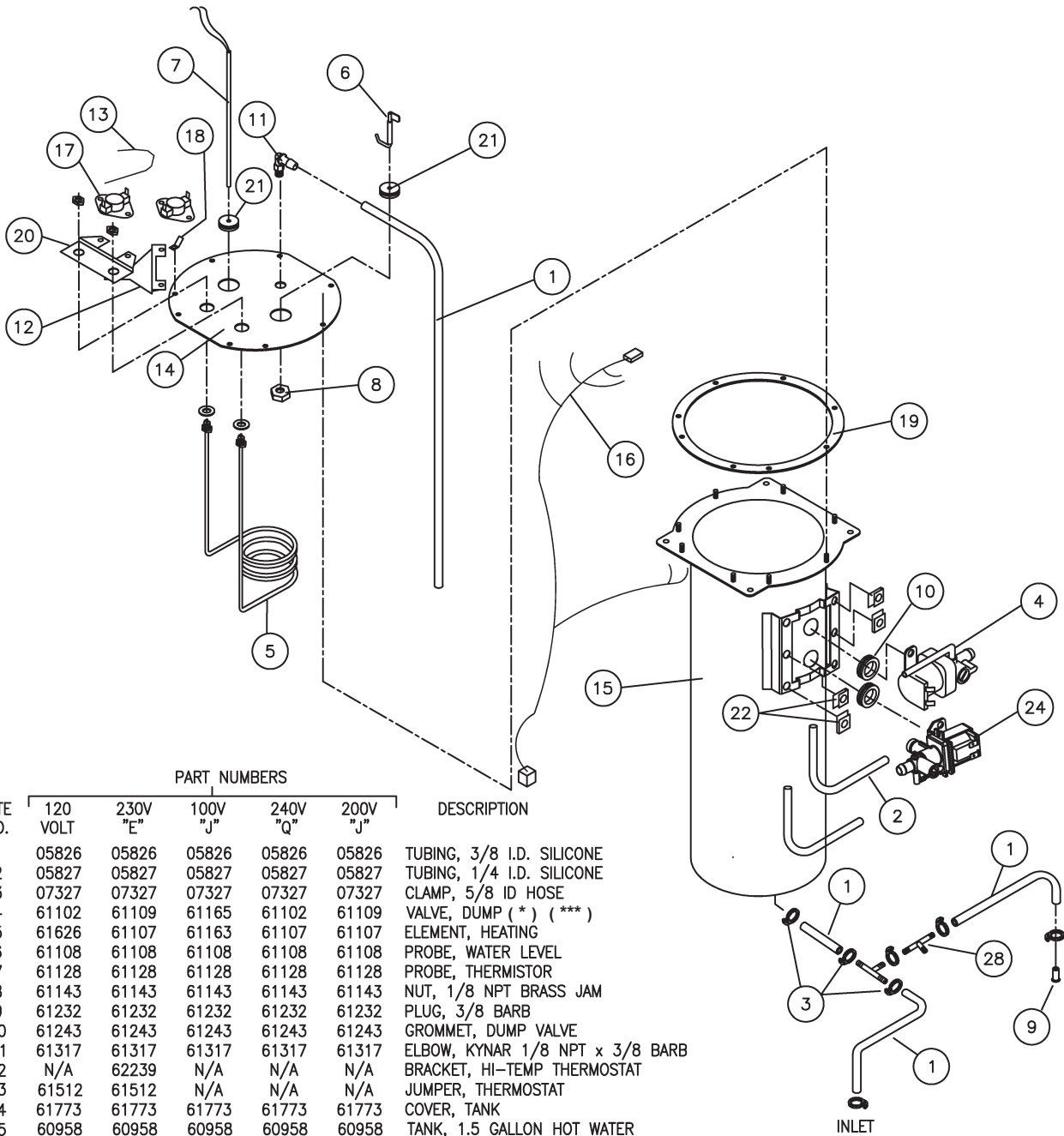

NOTE NO.	PART NUMBERS					DESCRIPTION
	120 VOLT	230V "E"	100V "J"	240V "Q"	200V "J"	
1	05826	05826	05826	05826	05826	TUBING, 3/8 I.D. SILICONE
2	05827	05827	05827	05827	05827	TUBING, 1/4 I.D. SILICONE
3	07327	07327	07327	07327	07327	CLAMP, 5/8 ID HOSE
4	61102	61109	61165	61102	61109	VALVE, DUMP (*) (***)
5	61626	61107	61163	61107	61107	ELEMENT, HEATING
6	61108	61108	61108	61108	61108	PROBE, WATER LEVEL
7	61128	61128	61128	61128	61128	PROBE, THERMISTOR
8	61143	61143	61143	61143	61143	NUT, 1/8 NPT BRASS JAM
9	61232	61232	61232	61232	61232	PLUG, 3/8 BARB
10	61243	61243	61243	61243	61243	GROMMET, DUMP VALVE
11	61317	61317	61317	61317	61317	ELBOW, KYNAR 1/8 NPT x 3/8 BARB
12	N/A	62239	N/A	N/A	N/A	BRACKET, HI-TEMP THERMOSTAT
13	61512	61512	N/A	N/A	N/A	JUMPER, THERMOSTAT
14	61773	61773	61773	61773	61773	COVER, TANK
15	60958	60958	60958	60958	60958	TANK, 1.5 GALLON HOT WATER
	63418	63418	63418	63418	63418	TANK, 1.5 GALLON HOT WATER (**)
16	61710	61710	61710	61710	61710	HARNES, TANK
17	62237	62237	62305	62237	62305	THERMOSTAT, HI-LIMIT
18	70635	70635	70635	70635	70635	TERMINAL, GROUND TAB
19	70821	70821	70821	70821	70821	GASKET, 1.5 GALLON TANK
20	62238	62238	62238	62238	62238	BRACKET, HI-TEMP THERMOSTAT
21	71147	71147	71147	71147	71147	GROMMET, PROBE
22	71166	71166	71166	71166	71166	NUT, TINNEMAN
23	61152	61152	61152	61152	61152	TEE, 7/16" BARBED
24	A71684	A71684	A71684	A71684	A71684	VALVE, DUMP 24VAC, DELTROL(**)

(*) = 71610 REPAIR KIT FOR DUMP VALVE

(**) = USED WITH PIC1KW MODELS ONLY

(***) = 61365 DUMP VALVE O-RING

PIC 1 Chassis Parts

(units with serial numbers beginning with "T")

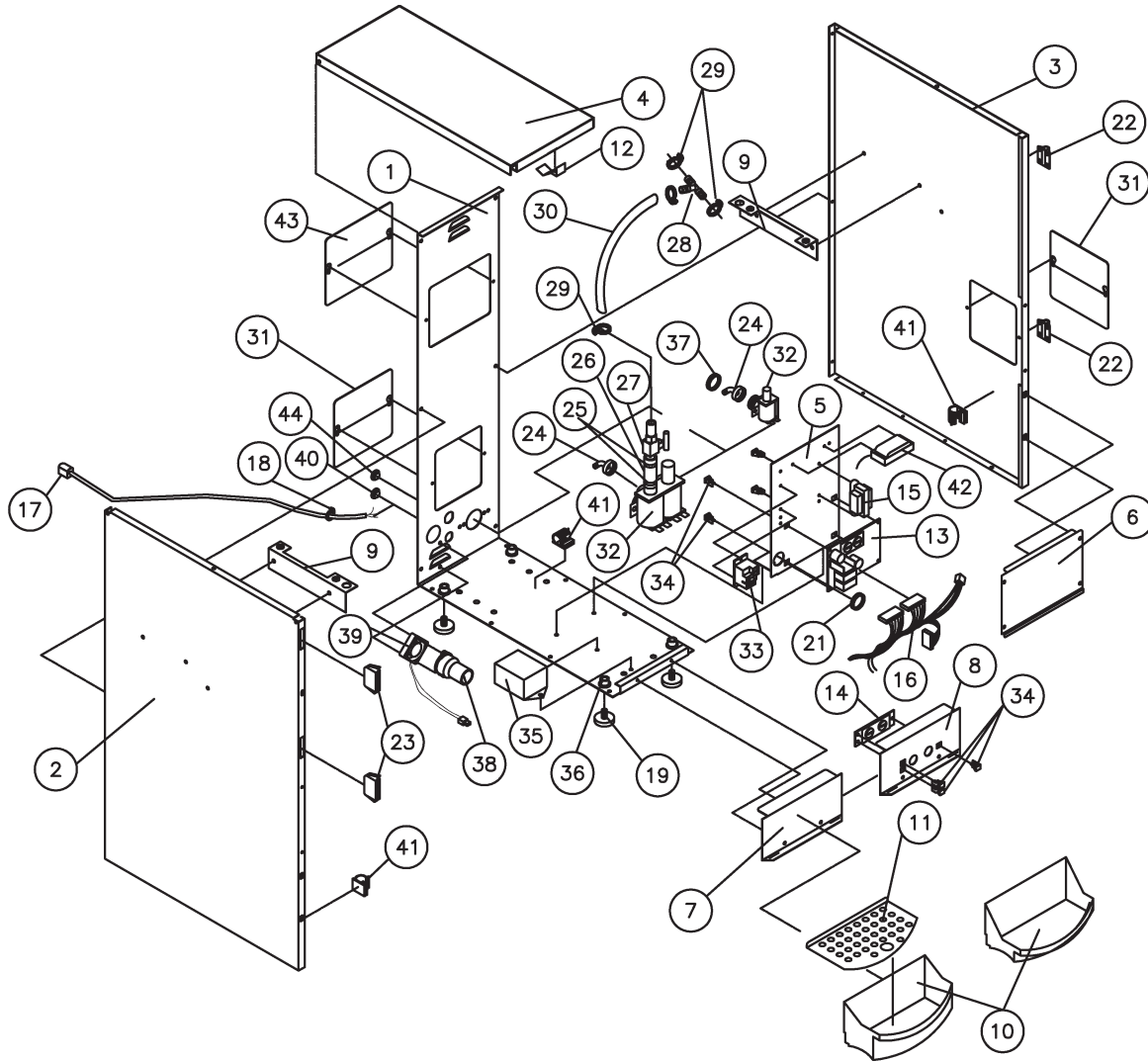

NOTE NO.	PART NUMBERS					DESCRIPTION
	120 VOLT	230V "E"	100V "J"	240V "Q"	200V "U"	
1	60946	60946	60946	60946	60946	BOTTOM/BACK, POWDER COATED
	60946L	60946L	60946L	60946L	60946L	BOTTOM/BACK, POWDER COATED, BLUE(*)
2	60954	60954	60954	60954	60954	PANEL, LEFT SIDE, POWDER COATED
	60954L	60954L	60954L	60954L	60954L	PANEL, LEFT SIDE, POWDER COATED, BLUE(*)
3	60955	60955	60955	60955	60955	PANEL, RIGHT SIDE, POWDER COATED
	60955L	60955L	60955L	60955L	60955L	PANEL, RIGHT SIDE, POWDER COATED, BLUE(*)
4	61607	61607	61607	61607	61607	COVER, TOP, POWDER COATED
	61607L	61607L	61607L	61607L	61607L	COVER, TOP, POWDER COATED, BLUE(*)
5	61610	61610	61610	61610	61610	BRACKET, CONTROL MOUNTING
6	61604	61604	61604	61604	61604	PANEL, UPPER SPLASH
	61604L	61604L	61604L	61604L	61604L	PANEL, UPPER SPLASH, BLUE(*)
7	61613	N/A	N/A	61613	N/A	PANEL, LWR. SPLASH, STANDARD
	61613L	61613L	61613L	61613L	61613L	PANEL, LWR. SPLASH, STANDARD, BLUE(*)
8	N/A	61704	61704	N/A	61704	PANEL, LWR. SPLASH, REMOTE
9	60947	60947	60947	60947	60947	BRACKET, TANK MOUNTING
10	61706	61706	61706	61706	61706	TRAY, DRAIN, PLASTIC
	61706L	61706L	61706L	61706L	61706L	TRAY, DRAIN, PLASTIC, BLUE(*)
	62335	62335	62335	62335	62335	TRAY, DRAIN PLASTIC LOW
11	61617	61617	61617	61617	61617	GRID, DRAIN, PLASTIC
	61617L	61617L	61617L	61617L	61617L	GRID, DRAIN, PLASTIC, BLUE(*)
12	61217	61217	61217	61217	61217	SPRING, HOPPER RETAINING
13	61632	(61632)	(61632)	61632	(61632)	CONTROLLER, PIC1 (MANUAL/OPT. OVERSEAS)
	N/A	61737	61737	N/A	61737	CONTROLLER, PIC1 (AUTO/ANALOG)
	(61739)	N/A	N/A	(61739)	N/A	CONTROLLER, PIC1 (AUTO/DIGITAL; OPT.)
14	N/A	61643	61643	N/A	61643	CTRL. BOARD, REMOTE (ANALOG OPT.)
15	61481	61470	61482	61481	61482	TRANSFORMER, CONTROL BOARD
16	61708	61712	61708	61708	61708	HARNESS, CONTROL BOARD
	63193	63193	N/A	N/A	N/A	HARNESS, CONTROL BOARD, AMBIENT(*)
	63413	63413	N/A	N/A	N/A	HARNESS, CONTROL BOARD, PIC1K W(**)
17	61530	61453	02880	60200	61736	POWER CORD
18	61479	86071	86071	N/A	86071	STRAIN RELIEF, HEYCO
	N/A	N/A	N/A	07920	N/A	STRAIN RELIEF, METAL ROMEX
19	61343L	61343L	61343L	61343L	61343L	BOLT, LEVELLER FOOT

NOTE NO.	PART NUMBERS					DESCRIPTION
	120 VOLT	230V "E"	100V "J"	240V "Q"	200V "U"	
21	60394	60394	60394	60394	60394	BUSHING, 7/8 O.D. x 3/4 I.D.
22	61792	61792	61792	61792	61792	HINGE, BLACK STAINLESS 2-LEAF
	61792L	61792L	61792L	61792L	61792L	HINGE, BLACK STAINLESS 2-LEAF, BLUE (*)
23	61235	61235	61235	61235	61235	CATCH, MAGNETIC SNAP-IN
24	61237	61237	61237	61237	61237	FITTING, HOSE TO 1/4 FLARE
25	60550	60550	N/A	60550	N/A	CLAMP, 11/16 STEPLESS EAR (*)
26	61153	61153	N/A	61153	N/A	TUBING, INNER BRAIDED, PVC (*)
27	61150	61150	N/A	61150	N/A	VALVE, AMBIENT FLOW CTRL. (*)
28	61152	61152	N/A	61152	N/A	TEE, 7/16 x 7/16 x 7/16 (*)
29	07327	N/A	N/A	07327	N/A	CLAMP, 5/8 I.D. HOSE (*)
30	71155	N/A	N/A	71155	N/A	TUBING, 5/16 I.D. SILICONE (*)
31	61438	61438	61438	61438	61438	PANEL, PLENUM ACCESS
	61438L	61438L	61438L	61438L	61438L	PANEL, PLENUM ACCESS, BLUE (*)
32	63493	61105	63493	63493	61105	VALVE, INLET
	61149	61631	N/A	61149	N/A	VALVE, INLET W/DUAL OUT. (*)
33	61131	61131	61131	61131	61131	RELAY, HEATER
34	61266	61266	61266	61266	61266	STANDOFF, PCB MOUNT
35	N/A	61170	N/A	N/A	N/A	FILTER, EMI, 230V
36	60380L	60380L	60380L	60380L	60380L	RIVNUT, 3/8-16
37	N/A	61514	N/A	N/A	N/A	O-RING, 0.906 I.D. x .210
38	61633	61633	61633	61633	61633	PLENUM/FAN MOUNT
39	61635	61635	61635	61635	61635	FAN, 24VDC, 40mm
40	71138	N/A	N/A	71138	N/A	PLUG, STR. RELIEF, 5/8"
41	71160	71160	71160	71160	71160	CLIP, HOSE W/ADHESIVE
42	61196	61468	61166	61196	61169	BALLAST (LIT MERCH. OPTION)
43	63431	63431	63431	63431	63431	PANEL ACCESS PICKW TOP REAR
44	N/A	61751	61751	61751	61751	PLUG, STR. RELIEF, 3/4"

(*) = USED WITH CAP1 MODELS ONLY
 (**) = USED WITH PIC1KW MODELS ONLY

PIC 1 Hopper Bracket

(units with serial numbers beginning with "T")

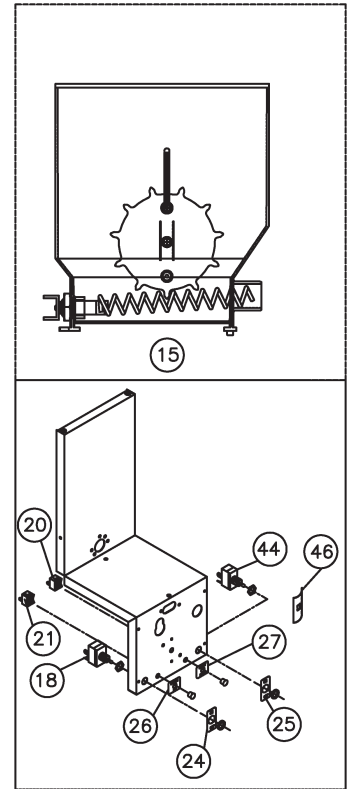
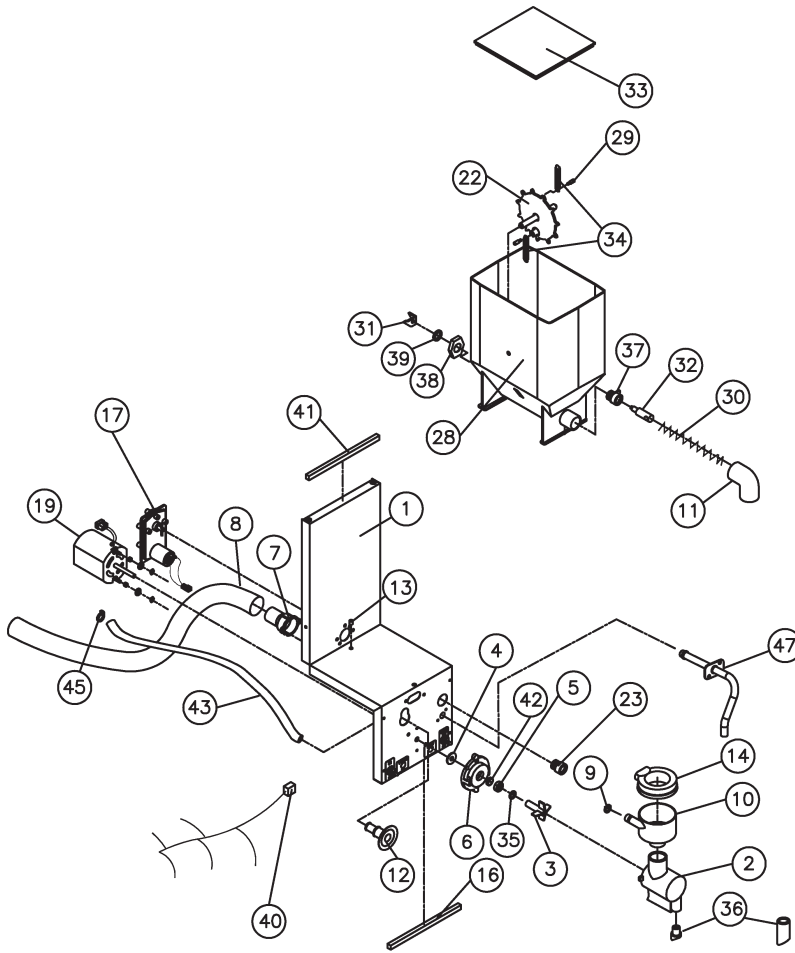

NOTE NO.	PART NUMBERS					DESCRIPTION
	120 VOLT	230V "E"	100V "J"	120/240V "Q"	200V "U"	
1	60948	60948	60948	60948	60948	BRACKET, HOPPER MOUNT.
	60948L	60948L	60948L	60948L	60948	BRACKET, HOPPER MOUNT, CAP1 (*)
	63419	63419	63419	63419	63419	BRACKET, HOPPER MOUNT, HW (**)
2	62395	62395	62395	62395	62395	CHAMBER, WHIPPER
3	61458	61458	61458	61458	61458	BLADE, WHIPPER FOUR
	65321K	65321K	65321K	65321K	65321K	WHIPPER BLADE 1.19" OD. (*)
4	61334	61334	61334	61334	61334	WASHER, SLINGER
5	61459	61459	61459	61459	61459	SEAL, LIP, 1/4 ID x 0.618 OD
6	61456	61456	61456	61456	61456	BASE, WHIPPER, SELF-LOCATING
7	61633	61633	61633	61633	61633	PLENUM, STEAM RECOVERY
8	61123	61123	61123	61123	61123	TUBING, 1 1/4" ID FLEXIBLE
9	61127	61127	61127	61127	61127	O-RING, 3/8 ID x 1/2 OD
10	61221	61221	61221	61221	61221	FUNNEL
11	61223	61223	61223	61223	61223	ELBOW, HOPPER
12	61226	61226	61226	61226	61226	FITTING, FUNNLL. QUIK CNCT.
13	61228	61228	61228	61228	61228	SPACER
14	61255	61255	61255	61255	61255	SHROUD, STEAM RECOVERY
15	60967	60967	60967	60967	60967	HOPPER, ASSEMBLY
16	61352	61352	61352	61352	61352	SEAL, HOPPER BKT.
17	61618	61618	61618	61618	61618	MOTOR, 12VDC AUGER
	65057	65057	65057	65057	65057	MOTOR ASSY, 30RPM DC COMPO W/BRASS SHAFT (*)
	65045	65045	65045	65045	65045	MOTOR ASSY 220 RPM, DC W/BRASS SHAFT(*)
18	61847	61466	61847	61466	61466	SWITCH, TOGGLE, 16A DPST
19	61116	61117	61116	61116	61117	MOTOR, WHIPPER
20	62436	61125	62436	61125	61125	LAMP, GREEN
21	05096	70271	61167	05096	70271	LAMP, RED
22	60944	60944	60944	60944	60944	AGITATOR, PINWHEEL
23	61480	61480	61480	61480	61480	STRAIN RELIEF, HEYCO 1240

NOTE NO.	PART NUMBERS					DESCRIPTION
	120 VOLT	230V "E"	100V "J"	120/240V "Q"	200V "U"	
24	61241	61241	61241	61241	61241	DECAL, POWER ON/OFF
25	61242	61242	61242	61242	61242	DECAL, RINSE ON/OFF
	63192	63192	63192	63192	63192	LABEL, RINSE-HOT-COLD(*)
26	61247	61247	61247	61247	61247	DECAL, POWER ON
27	61248	61248	61248	61248	61248	DECAL, READY
28	60942	60942	60942	60942	60942	HOPPER
29	61437	61437	61437	61437	61437	SCREW, 6-32 KNURL
30	61224	61224	61224	61224	61224	AUGER, 0.531 PITCH, STD.
	61302	61302	61302	61302	61302	AUGER, 0.718 PITCH (*)
	61278	61278	61278	61278	61278	AUGER, 0.406 PITCH (*) (**)
31	61225	61225	61225	61225	61225	LINK, AUGER DRIVE
32	61230	61230	61230	61230	61230	DRIVESHAFT, AUGER SPRING
33	60943	60943	60943	60943	60943	COVER, HOPPER
34	61313	61313	61313	61313	61313	SPRING, PINWHL. AGITR.
35	60741	60741	60741	60741	60741	O-RING, 0.239 x 0.070
36	61461	61461	61461	61461	61461	BUTTON, RESTRICTOR ANGLED
	65222	65222	65222	65222	65222	SPOUT 53 mm.x 6mm ID (*)
	62494	62494	62494	62494	62494	SPOUT, PSD LONGER
37	60966	60966	60966	60966	60966	BEARING, DRIVESHAFT
38	61314	61314	61314	61314	61314	5/8-11 UNC.
39	07301-04	07301-04	07301-04	07301-04	07301-04	WASHER, FLAT #10 SAE S.S.
40	61709	61709	61709	61709	61709	HARNES, HOPPER BRACKET
41	61159	61159	61159	61159	61159	SEAL, CLOSED CELL FOAM
42	61460	61460	61460	61460	61460	BEARING, 1/4 ID x 5/16 OD
43	71155	71155	71155	71155	71155	TUBING, 5/16 ID 3/32 WALL
44	61847	61847	61847	61847	61847	SWITCH, SPST RINSE
	63391	63391	63391	63391	63391	SLIDE SWITCH DP3T(*)
45	N/A	07327	N/A	N/A	N/A	CLAMP, 5/8 ID HOSE
46	63392	63392	63392	63392	63392	COVER SWITCH (*)
47	61763	61763	61763	61763	61763	HOT WATER SPOUT (**)

(*) = USED WITH CAP1 MODELS ONLY
 (**) = USED WITH PIC1KW MODELS ONLY

PIC 1 Door Assembly

(units with serial numbers beginning with "T")

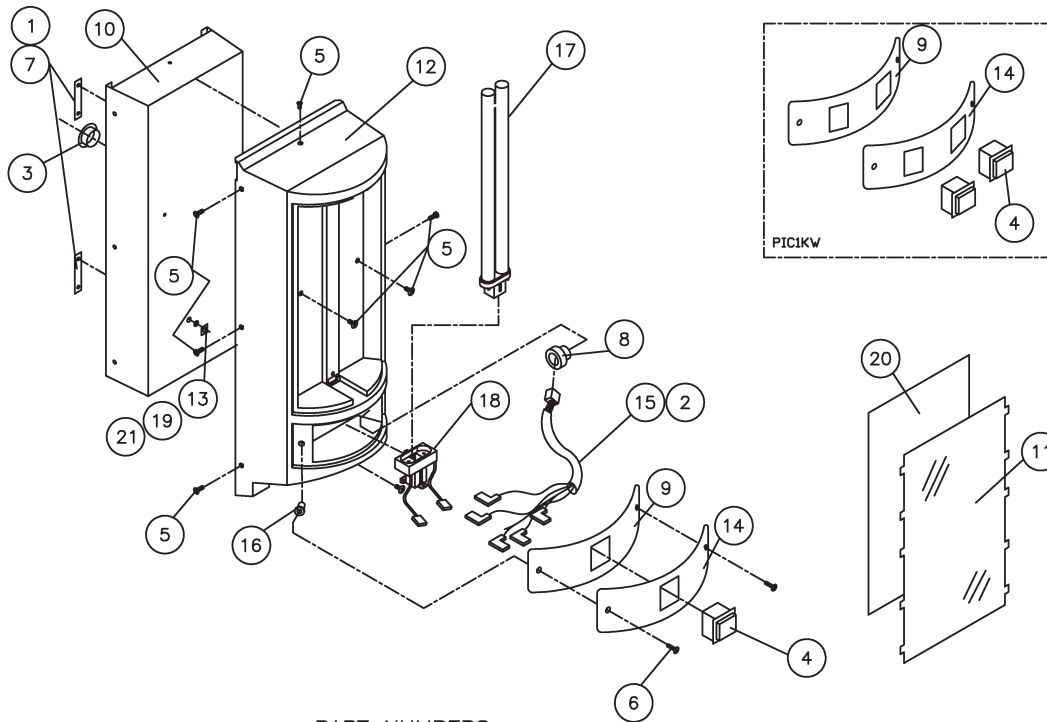

PART NUMBERS

NOTE NO.	PART NUMBERS					DESCRIPTION
	120 VOLT	240 VOLT "E"	100 VOLT "J"	120/240 VOLT "Q"	200 VOLT "J"	
1	07348-01	07348-01	07348-01	07348-01	07348-01	RIVET, POP
2	60080	60080	60080	60080	60080	CLAMP, 5/8 NYLON
3	60394	60394	60394	60394	60394	BUSHING, SNAP, 7/8"
4	61725	61725	61725	61725	61725	SWITCH, BREW DISPENSE
5	61303	61303	61303	61303	61303	SCREW, #8 x 3/8 TAPTITE
6	61304	61304	61304	61304	61304	SCREW, 6-32 x 1/2
7	61424	61424	61424	61424	61424	PLATE, STRIKER
8	61479	61479	61479	61479	61479	STRAIN RELIEF 3/4"
9	61609	61609	61609	61609	61609	PANEL, DISPENSE SWITCH
	63416	63416	N/A	N/A	N/A	PANEL, DISPENSE SWITCH (**)
10	60949	60949	60949	60949	60949	BRACKET, MERCH. REINF.
	60949L	60949L	60949L	60949L	60949L	BRACKET, MERCH. REINF., BLUE (*)
11	60952	60952	60952	60952	60952	COVER, GRAPHICS
12	60953	60953	60953	60953	60953	MERCHANDISER, PLASTIC
	60953L	60953L	60953L	60953L	60953L	MERCHANDISER, PLASTIC, BLUE (*)
13	61187	61187	61187	61187	61187	WASHER, #8 LOCK
14	61707	61745	61745	61707	61745	DECAL, SWITCHPANEL
	61707L	61745L	61745L	61707L	61745L	DECAL, SWITCHPANEL, BLUE (*)
	63417	63417	N/A	N/A	N/A	DECAL, SWITCHPANEL (**)
15	61711	61711	61711	61711	61711	HARNESS, DOOR INTERCONNECT
	61474	61474	N/A	N/A	N/A	HARNESS, DOOR INTERCONNECT (**)
16	60381	60381	60381	60381	60381	RIVNUT, 6-32 AVK
17	60941	60941	60941	60941	60941	LAMP, FLUORESCENT MINI BI-PIN
18	60945	60945	60945	60945	60945	SOCKET, FLUORESCENT MINI BI-PIN
19	61272	61272	61272	61272	61272	SCREW, #8 x 3/8 GREEN
20	60968	60968	60968	60968	60968	GRAPHIC, PIC1K, CAP
	60957	60957	60957	60957	60957	GRAPHIC, PIC1K, CHY
	63403	63403	63403	63403	63403	GRAPHIC, CAP1, CAP
	63404	63404	63404	63404	63404	GRAPHIC, CAP1, COF
	63407	63407	63407	63407	63407	GRAPHIC, PIC1K, COF
	N/A	63415	N/A	N/A	N/A	GRAPHIC, PIC1K, ANT
21	70635	70635	70635	70635	70635	TERMINAL, 1/4 M TAB

(*) = USED WITH CAP1 MODELS ONLY

(**) = USED WITH PIC1KW MODELS ONLY

PIC 2/3 Chassis Parts

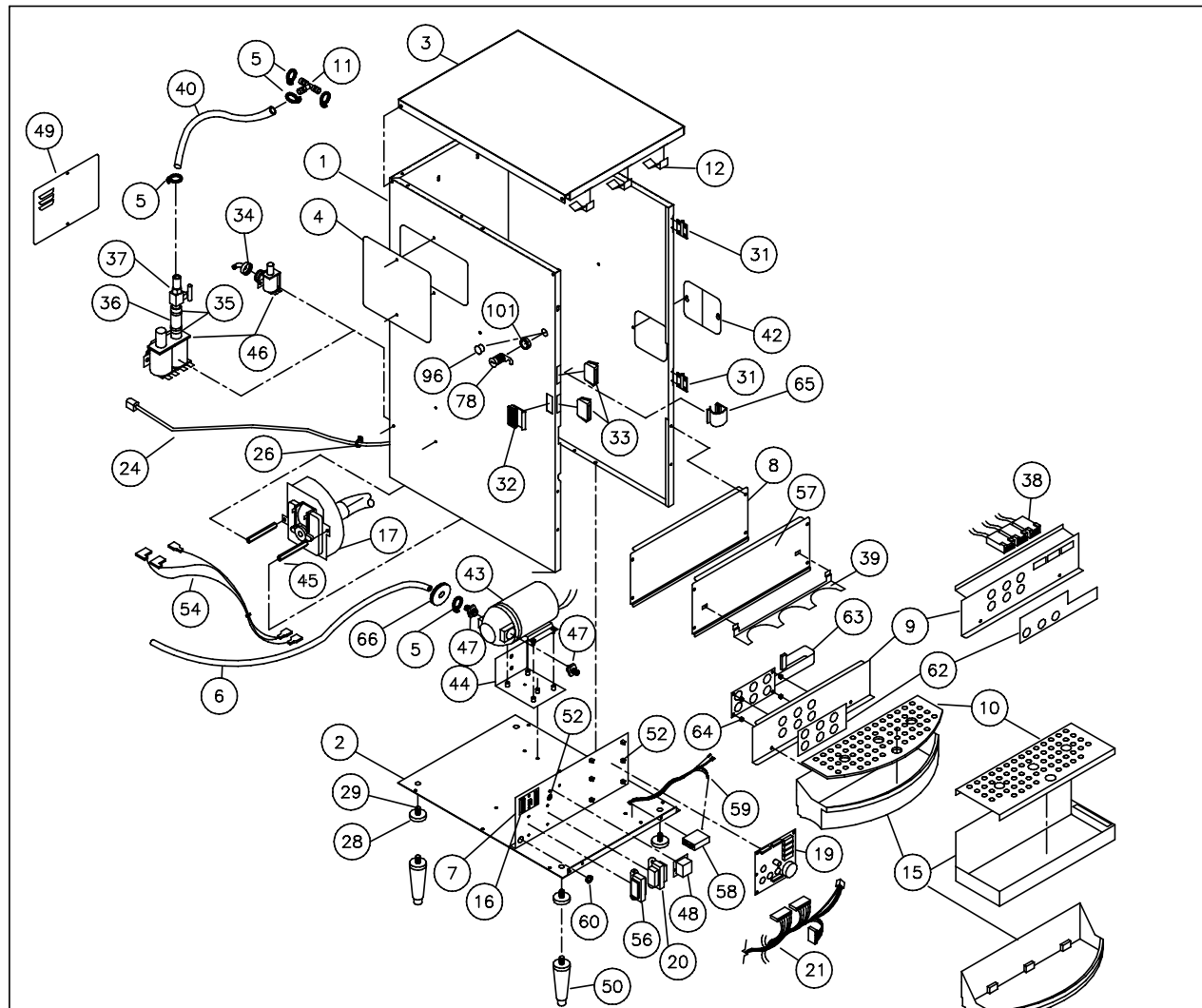

NOTE NO.	PART NUMBERS					DESCRIPTION	NOTE NO.	PART NUMBERS					DESCRIPTION
	100V "J"	120 VOLT	240V "Q"	200V "E"	230V "E"			100V "J"	120 VOLT	240V "Q"	200V "E"	230V "E"	
1	62513	62513	62513	62513	62513	CASING, BLACK POWDER COATED	34	61237	61237	61237	61237	61237	FITTING, HOSE TO 1/4 FLARE
2	61378	61378	61378	61378	61378	CASING, STAINLESS STEEL	35	60550	60550	60550	60550	60550	CLAMP, 11/16 STEPLESS EAR
	61201	61201	61201	61201	61201	BOTTOM, POWDER COATED	36	61153	61153	61153	61153	61153	TUBING, INNERBRAIDED PVC
	61377	61377	61377	61377	61377	BOTTOM, STAINLESS STEEL	37	61150	61150	61150	61150	61150	VALVE, AMBIENT FLOW CONTROL
3	61207	61207	61207	61207	61207	COVER, POWDER COATED	38	61540	61540	61540	61754	61754	COUNTER, TOTALIZER
	61379	61379	61379	61379	61379	COVER, STAINLESS STEEL	39	61366	61366	61366	61366	61366	BRACKET, CUP LOCATOR
4	61423	61423	61423	61423	61423	PLATE, POWDER COATED SIDE	40	71155	71155	71155	71155	71155	TUBING, 5/16 ID SILICONE
	61376	61376	61376	61376	61376	PLATE, SS SIDE ACCESS	41	61152	61152	61152	61152	61152	TEE, 3/8 x 3/8 x 3/8 BARBED
5	07327	07327	07327	07327	07327	CLAMP, 5/8 ID HOSE	42	61438	61438	61438	61438	61438	PANEL, STEAM PLENUM ACCESS
6	05826	05826	05826	05826	05826	TUBING, 3/8 ID SILICONE		61441	61441	61441	61441	61441	PANEL, S.S. STEAM PLENUM ACCESS
7	61473	61473	61473	61473	61473	BRACKET, CONTROL MOUNTING	43	61290	61290	61290	61543	61543	PUMP(OPTION "P")
8	61212	61212	61212	61212	61212	PANEL, UPPER SPLASH	44	61254	61254	61254	61254	61254	BRACKET, PUMP MOUNTING (OPTION "P")
	61399	61399	61399	61399	61399	PANEL, UPPER SPLASH #3 S.S.	45	60245	60245	60245	60245	60245	SPACER, BOILER
9	61213	61213	61213	61213	61213	PANEL, LOWER SPLASH	46	63493	63493	63493	60978	60978	VALVE, INLET 1.2 GPM
	61486	N/A	N/A	61486	61486	PANEL, LOWER SPLASH REMOTE		61104	61104	61104	61105	61105	VALVE, INLET 1.2 GPM (ALT)
	61528	N/A	N/A	61528	61528	PANEL, LOWER SPL. REMOTE/COUNTERS		61149	61149	61149	N/A	N/A	VALVE, 120 VOLT DUAL OUTLET INLET
10	N/A	61769	N/A	N/A	N/A	PANEL, LOWER SPLASH COUNTERS	47	61121	61121	61121	61121	61121	FITTING, 3/BNPT X 3/BBARB (OPTION"P")
	61892	61892	61892	61892	61892	GRID, ROUNDED PLASTIC	48	61131	61131	61131	61131	61131	RELAY, HEATER
	61368	61368	61368	61368	61368	GRID, ROUNDED BRUSHED SS DRAIN	49	61141	61141	61141	61141	61141	PLATE, POWDER COATED BACK ACCESS
	61382	61382	61382	61382	61382	GRID, NON-ROUNDED STAINLESS		61375	61375	61375	61375	61375	PLATE, SS BACK ACCESS
11	61152	61152	61152	61152	61152	TEE, 3/8 x 3/8 x 3/8 BARBED	50	71256	71256	71256	71256	71256	LEG, 4" 3/8-16 PLASTIC
12	61217	61217	61217	61217	61217	SPRING, HOPPER RETAINING		61410	61410	61410	61410	61410	LEG, 4" 3/8-16 DIE CAST METAL
15	61198	N/A	N/A	61198	61198	TRAY, BLACK ROUNDED PLASTIC DRAIN	52	61266	61266	61266	61266	61266	STANDOFF, REVERSE EDGEMOUNT
	N/A	62444	N/A	N/A	N/A	TRAY, RECTANGLE STAINLESS	54	N/A	N/A	N/A	N/A	61273	HARNES, BLOWER
	N/A	62336	N/A	N/A	N/A	TRAY, LOWERED DRAIN I-MOLDED	56	61196	61196	61196	61468	61468	BALLAST
16	61338	61338	61338	61338	61338	BOARD, TERMINAL	57	61367	61367	61367	61367	61367	PANEL, #3 S.S. UPPER SPLASH
17	61103	61103	61103	61111	61111	BLOWER	58	N/A	N/A	N/A	N/A	61170	FILTER, FMI
19	61800	61800	61800	61800	61800	CONTROLLER, STANDARD	59	N/A	N/A	N/A	N/A	61476	HARNES, FMI FILTER
	62500	62500	62500	62500	62500	CONTROLLER, AUTO/1-BUTTON ONLY	60	60394	60394	60394	60394	60394	BUSHING, 7/8" OD HEYCO
20	61482	61481	61481	61482	61470	TRANSFORMER	61	10073	10073	10073	10073	10073	LABEL, GROUND SYMBOL
21	61890	61890	61890	61890	61472	HARNES, CHASSIS/CONTROL BOARD	62	61508	N/A	N/A	61508	61508	DECAL, REMOTE POT INDICATOR
24	61530	61530	60200	61453	61453	ELECTRICAL CORD	63	61766	N/A	N/A	61766	61766	DECAL, REMOTE/ COUNTER/ 3-PORTION
26	61479	61479	N/A	86071	86071	STRAIN RELIEF	64	61539	N/A	N/A	61539	61539	BOARD, REMOTE SPEED POT
	N/A	N/A	07920	N/A	N/A	STRAIN RELIEF, METAL ROMEX	65	61615	N/A	N/A	61615	61615	STANDOFF
28	61344	61344	61344	61344	61344	PAD, LEVELER FOOT	66	61510	N/A	N/A	61510	61510	CLIP, SIPHON HOSE BLACK W/ ADHESIVE
29	61343	61343	61343	61343	61343	BOLT, LEVELER FOOT	67	N/A	N/A	N/A	N/A	61550	GROMMET, BLACK (OPTION "P" CE)
30	60394	60394	60394	60394	60394	BUSHING, 7/8 OD x 3/4 ID	78	61154	61154	61154	61154	61154	KEY LOCK (OPTION)
31	61792	61792	61792	61792	61792	HINGE, BLACK STAINLESS 2-LEAF	96	61751	61751	61751	61751	61751	PLUG, STRAIN RELIEF
	61393	61393	61393	61393	61393	HINGE, STAINLESS STEEL	101	62219	62219	62219	62219	62219	SPACER, LOCK (OPTION)
32	61234	61234	61234	61234	61234	LATCH, MERCHANDISER							
33	61235	61235	61235	61235	61235	CATCH, MAGNETIC SNAP-IN							

PIC 2/3 Hopper Bracket

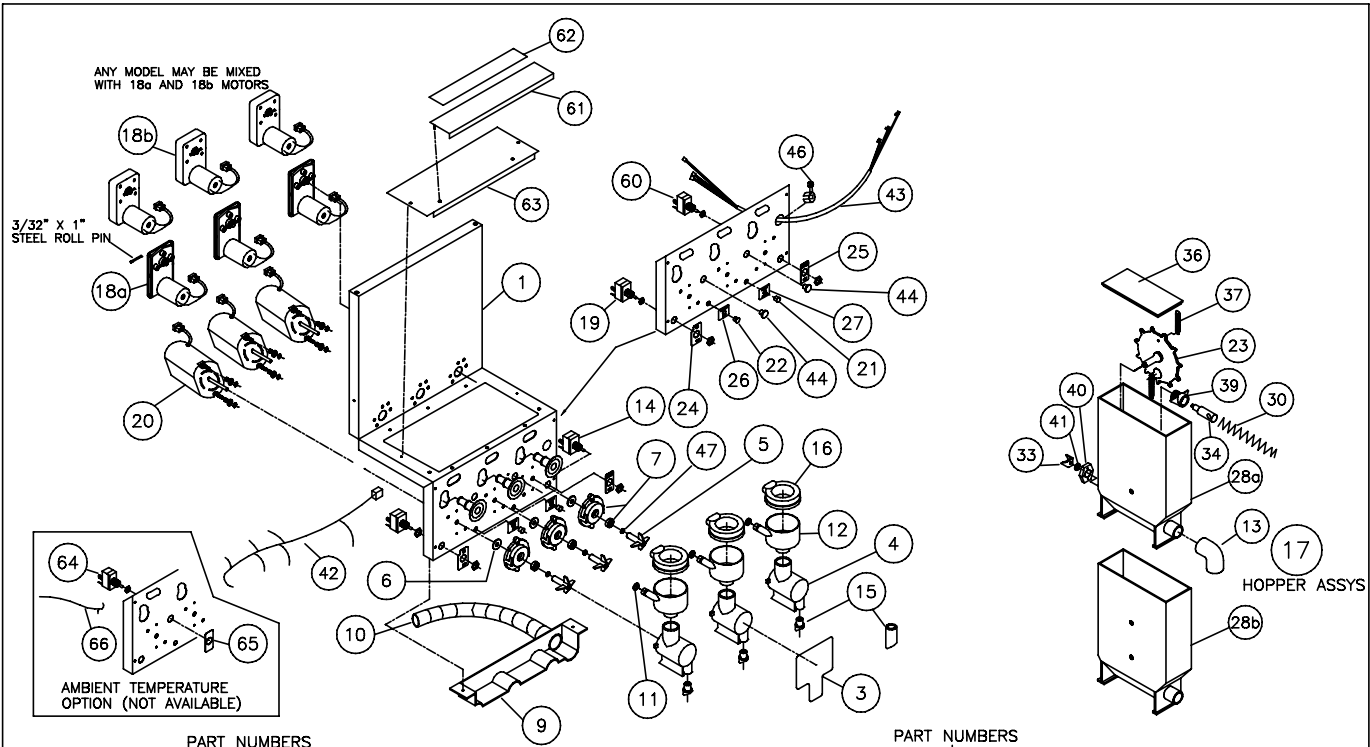

NOTE NO.	PART NUMBERS					DESCRIPTION	NOTE NO.	PART NUMBERS					DESCRIPTION
	100V "J"	120 VOLT	240V "Q"	200V "J"	230V "E"			100V "J"	120 VOLT	240V "Q"	200V "J"	230V "E"	
1	65209	65209	65209	65209	65209	BRACKET, HPR MTG CP3-PIC2/3	26	61247	61247	61247	61247	61247	DECAL, POWER ON
3	61244	61244	61244	61244	61244	PLATE, DISPENSE HEAD TRIM	27	61248	61248	61248	61248	61248	DECAL, READY
4	62395	62395	62395	62395	62395	CHAMBER, WHIPPER	28a	61222	61222	61222	61222	61222	HOPPER, 5lb.
5	61458	61458	61458	61458	61458	BLADE, WHIPPER FOUR	28b	61489	61489	61489	61489	61489	HOPPER, 5lb. DUAL PINWHEEL
6	61334	61334	61334	61334	61334	WASHER, SLINGER	30	61224	61224	61224	61224	61224	AUGER, STD 0.531 PITCH
7	61523	61523	61523	61523	61523	ASSY, WHIPPER BASE/SEAL/BRNG.		61302	61302	61302	61302	61302	AUGER, 0.718 PITCH
9	61197	61197	61197	61197	61197	PLENUM, STEAM RECOVERY	33	61225	61225	61225	61225	61225	LINK, AUGER DRIVE
10	61123	61123	61123	61123	61123	TUBING, 1 1/4" ID FLEXIBLE	34	61230	61230	61230	61230	61230	DRIVESHAFT, AUGER SPRING
11	61127	61127	61127	61127	61127	O-RING, 3/8 ID x 1/2 OD	36	61315	61315	61315	61315	61315	COVER, 5lb. HOPPER
12	61221	61221	61221	61221	61221	FUNNEL	37	61313	61313	61313	61313	61313	SPRING, PINWHEEL AGITATOR
13	61223	61223	61223	61223	61223	ELBOW, HOPPER	39	61246	61246	61246	61246	61246	BEARING, DRIVESHAFT
14	61226	61226	61226	61226	61226	FITTING, FUNNEL QUICK CONNECT	40	61314	61314	61314	61314	61314	PALNUT, 5/8-11 UNC.
15	61461	61461	61461	61461	61461	BUTTON, RESTRICTOR ANGLED	41	07301-04	07301-04	07301-04	07301-04	07301-04	WASHER, FLAT #10 SAE S.S.
	62494	62494	62494	62494	62494	SPOUT, PSD LONGER	42	61891	61891	61891	61891	61471	HARNES, DC HOPPER BRACKET
16	61255	61255	61255	61255	61255	SHROUD, STEAM RECOVERY	43	61474	61474	61474	61474	61474	HARNES, DOOR INTERCONNECT
17	61372	61372	61372	61372	61372	HOPPER, ASY .531 AUG 1-PW		61820	61820	61820	61820	61820	HARNES, DOOR INT. 3-PORT
	61442	61442	61442	61442	61442	HOPPER, ASY .718 AUG 1-PW	44	88737	88737	88737	88737	88737	PLUG, HOLE 7/16"
	61837	61837	61837	61837	61837	HOPPER, ASY .531 DUAL PW	46	61480	61480	61480	61480	61480	STRAIN RELIEF, 7/8 HOLE
	61490	61490	61490	61490	61490	HOPPER, ASY .718 DUAL PW	47	60741	60741	60741	60741	60741	O-RING, 0.239 ID x 0.070 CS
18a	61618	61618	61618	61618	61618	MOTOR, AUGER 145RPM CAP	59	05826	05826	05826	05826	05826	TUBING, 3/8" ID SILICONE
18b	65057	65057	65057	65057	65057	MOTOR, AUGER 30RPM SOLUBLE	60	61847	61847	61847	61847	61847	SWITCH, SPST RINSE
19	61847	61847	61466	61466	61466	SWITCH, TOGGLE	61	61839	61839	61839	61839	61839	PLATE, CLEAN-OUT COVER
20		61116-01		61117	61117	MOTOR, WHIPPER	62	61848	61848	61848	61848	61848	DECAL, "DO NOT POUR"
21	63499	63495	63495	63497	63497	LAMP, GREEN	63	65208	65208	65208	65208	65208	COVER, HOPPER SHELF
22	63516	63496	63496	63498	63498	LAMP, RED	64	61467	61467	61467	61467	61467	SWITCH SPDT TOGGLE (AMBIENT)
23	61316	61316	61316	61316	61316	AGITATOR, 5lb. PINWHEEL	65	61156	61156	61156	61156	61156	LABEL, HOT/COLD
24	61889	61889	61889	61889	61889	DECAL, POWER ON/OFF	66	61158	61158	61158	61158	61158	HARNES, AMBIENT TEMP
25	61242	61242	61242	61242	61242	DECAL, RINSE ON/OFF							

PIC 2/3 Tank Assembly

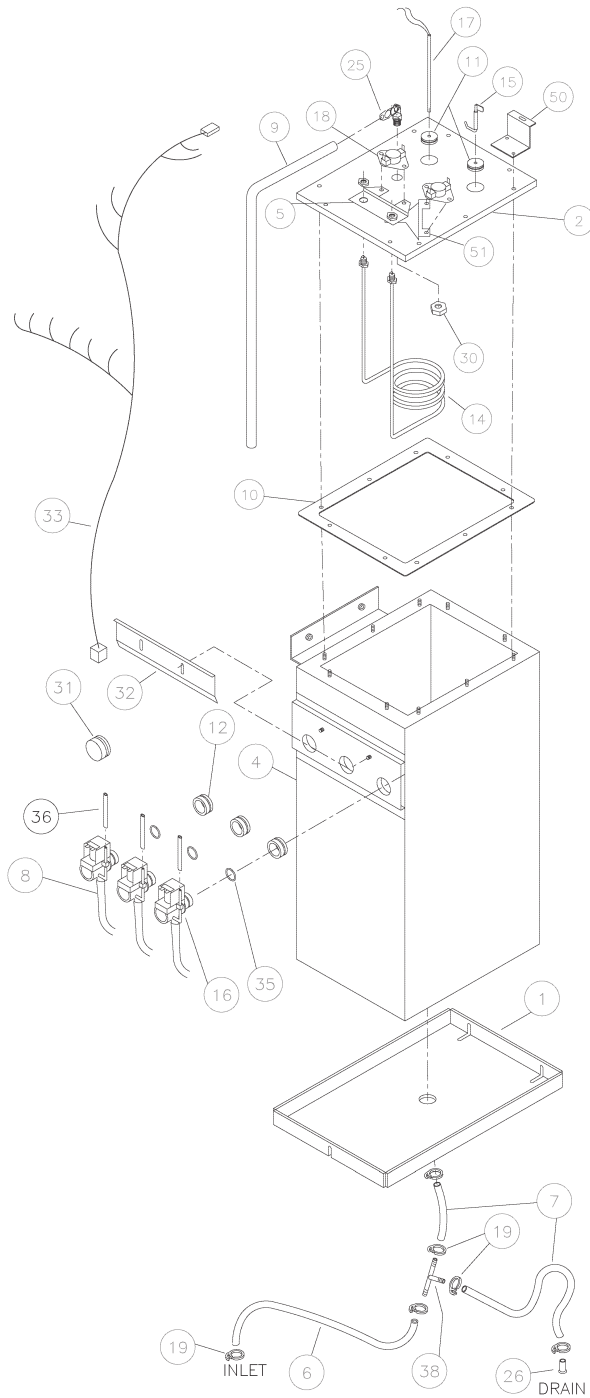

PART NUMBERS

NOTE NO.	100V "J"	120 VOLT	240V "Q"	200V "J"	230V "E"	DESCRIPTION
1	61845	61845	61845	61845	61845	BRACKET, TANK RETAINING
2	61842	61842	61842	61842	61842	COVER, TANK
4	61841	61841	61841	61841	61841	TANK, 3.5 GALLON WELDED
5	62238	62238	62238	62238	62238	BRACKET, HI-TEMP THERMOSTAT
6	05826	05826	05826	05826	05826	TUBING, INLET VALVE
7	05826	05826	05826	05826	05826	TUBING, TANK DRAIN
8	71155	71155	71155	71155	71155	TUBING, DUMP VALVE (PIC)
9	05826	05826	05826	05826	05826	TUBING, VENT
10	61844	61844	61844	61844	61844	GASKET, 3.5 GALLON TANK
11	71147	71147	71147	71147	71147	GROMMET, PROBE
12	61243	61243	61243	61243	61243	GROMMET, DUMP VALVE
14	61626	61626	61107	61107	61107	ELEMENT, HEATING
15	61108	61108	61108	61108	61108	PROBE, WATER LEVEL
16	61165	63477	63477	61109	61109	VALVE, DUMP
		61102	61102			VALVE, ALTERNATE DUMP
	71610	63486	63486	71610	71610	KIT REPAIR, DUMP VALVE
		71610	71610			KIT REPAIR, ALTERNATE DUMP VALVE
17	61128	61128	61128	61128	61128	PROBE, THERMISTOR
18	62305	62305	62305	62305	62305	THERMOSTAT, HI-LIMIT
19	07327	07327	07327	07327	07327	CLAMP, 5/8 ID HOSE
25	61317	61317	61317	61317	61317	ELBOW, KYNAR 1/8NPTx3/8BBARB
	61417	61417	61417	61417	61417	ELBOW, KYNAR 1/8NPTx3/8BBARB
26	61232	61232	61232	61232	61232	PLUG, 3/8 BARB
30	61143	61143	61143	61143	61143	NUT, 1/8 NPT BRASS JAM
31	61229	61229	61229	61229	61229	GROMMET, PLUG
32	61137	61137	61137	61137	61137	CLIP, VALVE RETAINING
33	61890	61890	61890	61890	61268	HARNES, TANK PIC, PSD
35	61365	61365	61365	61365	61365	O-RING, DUMP VALVE
36	05872	05872	05872	05872	05872	TUBING, 1/4" SILICONE
38	61152	61152	61152	61152	61152	TEE, 7/16" BARBED
50	62306	62306	62306	62306	62306	BRACKET, TANK PIC2/3
51					62239	BRACKET, HI-TEMP T-STAT CE

PIC 2/3 Door Assembly

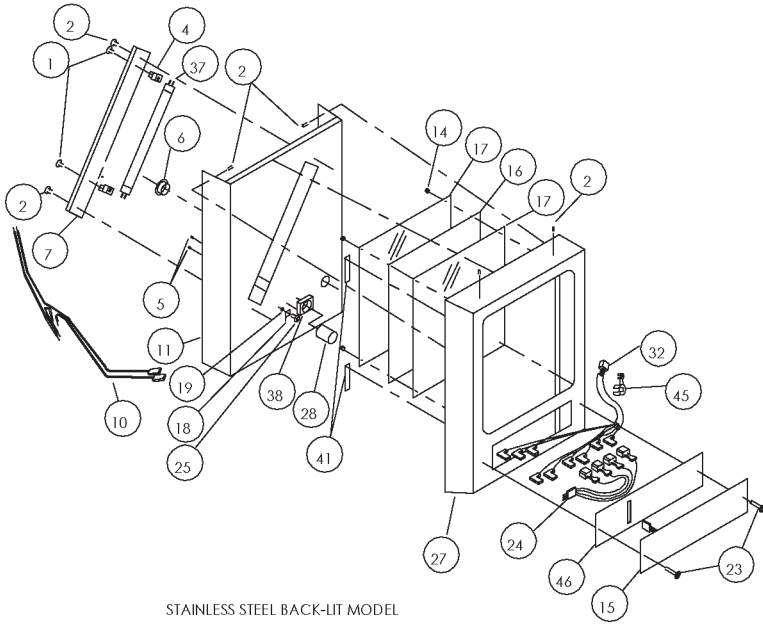

STAINLESS STEEL BACK-LIT MODEL

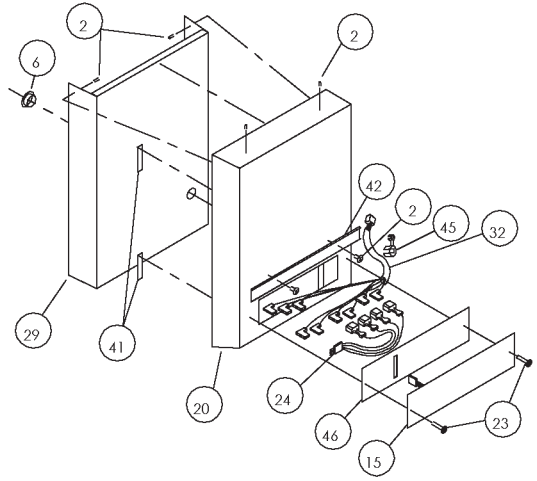

STAINLESS STEEL NON-LIT MODEL

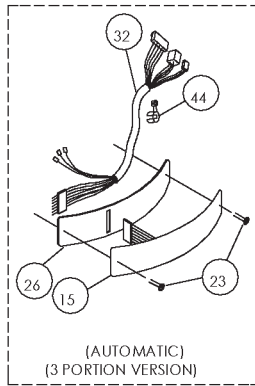
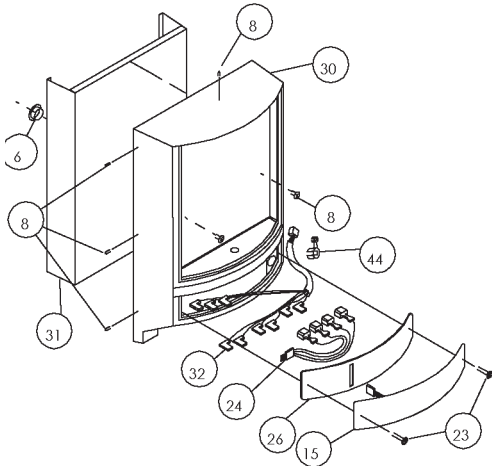

[AUTOMATIC]
[3 PORTION VERSION]

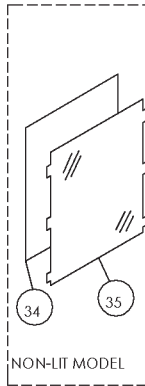

NON-LIT MODEL

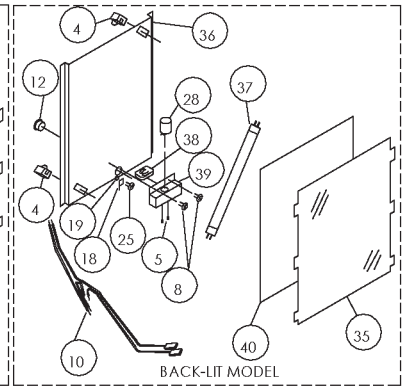

BACK-LIT MODEL

BLACK ROUNDED MERCHANDISER MODELS

NOTE NO.	PART NUMBERS			DESCRIPTION	NOTE NO.	PART NUMBERS			DESCRIPTION
	100V "J" VOLT	200V "J" "Q"	240V "Q"			100V "J" VOLT	200V "J" "Q"	240V "Q"	
1	07023-04	07023-04	07023-04	SCREW, 6-32 X 1/4	26	61824	61824	61824	PANEL, SWITCH TOUCH PAD CURVED
2	07026-07	07026-07	07026-07	SCREW, 8-32 X 3/8	27	61397	61397	61397	SKIN, BACK LIT SS MERCHANDISER
4	61513	61513	61513	HOLDER, MINI BI-PIN	28	61194	61194	61194	STARTER
5	62522	62522	62522	SCREW, 4-40 X 3/8	29	61385	61385	61385	COVER, SS MERCHANDISER BACK
6	60394	60394	60394	BUSHING, 7/8" OD X 3/4" ID	30	61199	61199	61199	DOOR, PLASTIC MERCHANDISER
7	61358	61358	61358	BRACKET, LAMP HOLDER	31	62514	62514	62514	BRACKET, MERCH. REINFORCING
8	61303	61303	61303	SCREW, #8 X 3/8 BLACK SS	32	61474	61474	61474	HARNES, MERCHANDISER TO CHASSIS
10	61136	61136	61136	HARNES, LAMP	31	61820	61820	61820	HARNES, DOOR INT. 3-PORTION
11	61356	61356	61356	COVER, SS MERCHANDISER BACK	34	61783	61783	61783	GRAPHIC, NON-LIT CAPPUCCINO
12	61266	61266	61266	BUSHING	35	61219	61219	61219	COVER, PLASTIC GRAPHICS
14	86086	86086	86086	NUT, 8-32 NYLON	36	61120	61120	61120	BRACKET, LAMP MOUNTING
15	62301	62301	62301	TOUCHPAD, PIC2 MANUAL	37	61118	61118	61118	LAMP, F815
	61840	61840	61840	TOUCHPAD, PIC3 MANUAL	38	62521	62521	62521	BASE, 4-36 STARTER
	62302	62302	62302	TOUCHPAD, PIC2 3 PORTION W/O HOT WATER	39	61134	61134	61134	SHIELD, IGNITOR
	61826	61826	61826	TOUCHPAD, PIC3 3 PORTION W/O HOT WATER	40	61776	61776	61776	GRAPHIC, BACK-LIT CAPPUCCINO
16	61784	61784	61784	GRAPHIC, SS BACKLIT CAPPUCCINO		61806	61806	61806	GRAPHIC, BACK-LIT COFFEE
17	61359	61359	61359	MEDALLION, SS MERCHANDISER FRONT	41	61424	61424	61424	PLATE, STRIKER
18	70635	70635	70635	TERMINAL LUG	42	61425	61425	61425	CHANNEL, FLAVOR STRIP (OPTIONAL)
19	61186	61186	61186	WASHER, #8 INTERNAL STAR	44	61479	61479	61479	STRAIN RELIEF, 3/4" HOLE
20	61384	61384	61384	SKIN, SS NON-BACKLIT MERCHANDISER	45	61480	61480	61480	STRAIN RELIEF, 7/8" HOLE
23	61305	61305	61305	SCREW, 8-32 X 5/8 BLACK	46	62012	62012	62012	PANEL, SWITCH TOUCH PAD FLAT
24	62303	62303	62303	HARNES, FIG TAIL T-PAD MANUAL					
25	61272	61272	61272	SCREW, #8 X 3/8 GREEN					

PIC 4 Chassis Parts

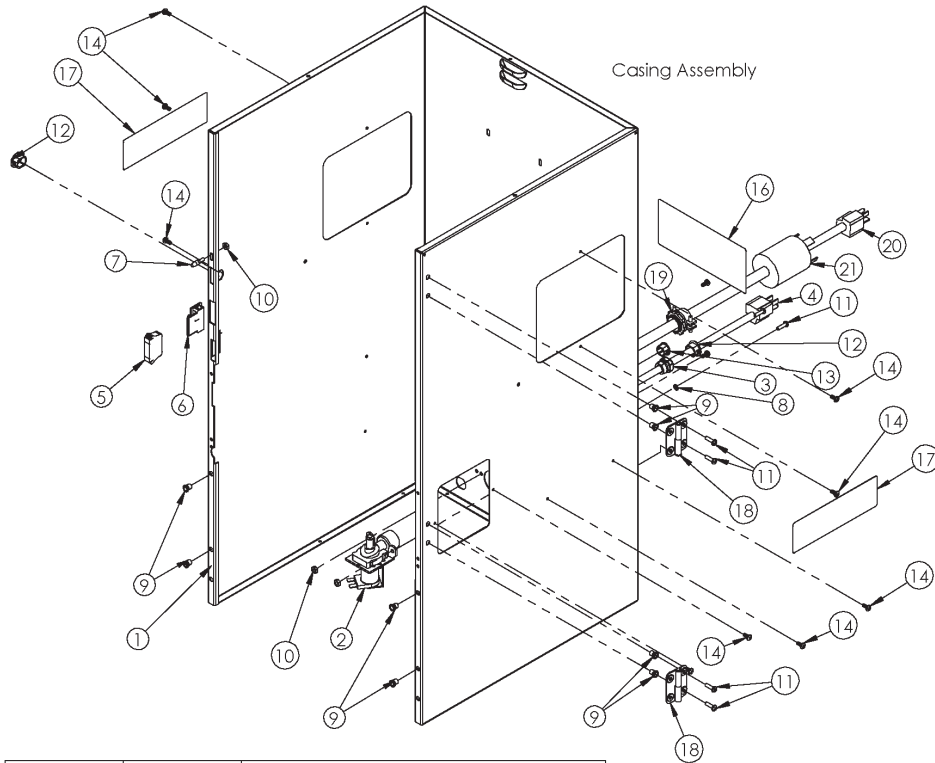

ITEM NO.	PART NO.	DESCRIPTION
1	62543	Casing, PIC4
2	63493	Valve, 120 V Inlet 1.2 Gpm
3	61479	STRAIN RELIEF, HEYCO
4	61530	Cord, Power Supply 14-3 SJO
5	61235	Latch, Magnetic Snap-In
6	61234	Latch, Snap-In
7	61270	Enter Title
8	61186	Washer, #8 Int Lock
9	82096	RIVNUT, 8-32 AKS4-832-80
10	71129	NUT, 8-32 KEPS SS
11	61305	Screw, 8-32 x 5/8 black
12	61751	Plug, Hole, .75x.625 DD
13	71138	Plug, Hole, .625x.563 DD
14	61303	Screw, #8 x 3/8 black trilobe
15	61341	Decal, 1/4 Flr Wtr Connection
16	61319	Decal, Caution
17	61326	Decal, Caution Side PIC
18	61792	HINGE, PWDR COATED SS 2 LEAF
19	07920	Connector, 3/4 Conduit Metal Romex
20	60106	Cord, Power 12-3 SJO 5-20
21	60200	Cord, Power 12-4 SJO L14-20

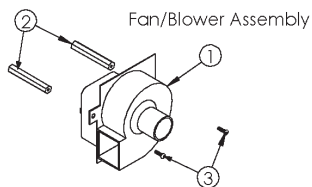

ITEM NO.	PART NO.	DESCRIPTION
1	61103	Fan, Blower 120V
2	60245	Spacer, Boiler
3	61304	Screw, 6-32 x 1/2 PPH, SS

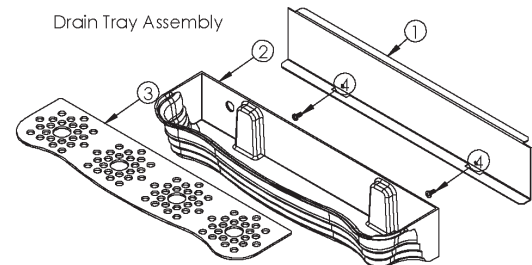

ITEM NO.	PART NO.	DESCRIPTION
1	62541	Panel, Lower Splash PIC4
2	62662	Tray, Drain PIC4 (ref 62546)
3	62545	Grid, Drain PIC4
4	61303	Screw, #8 x 3/8 black trilobe

PIC 4 Control Bracket Assembly

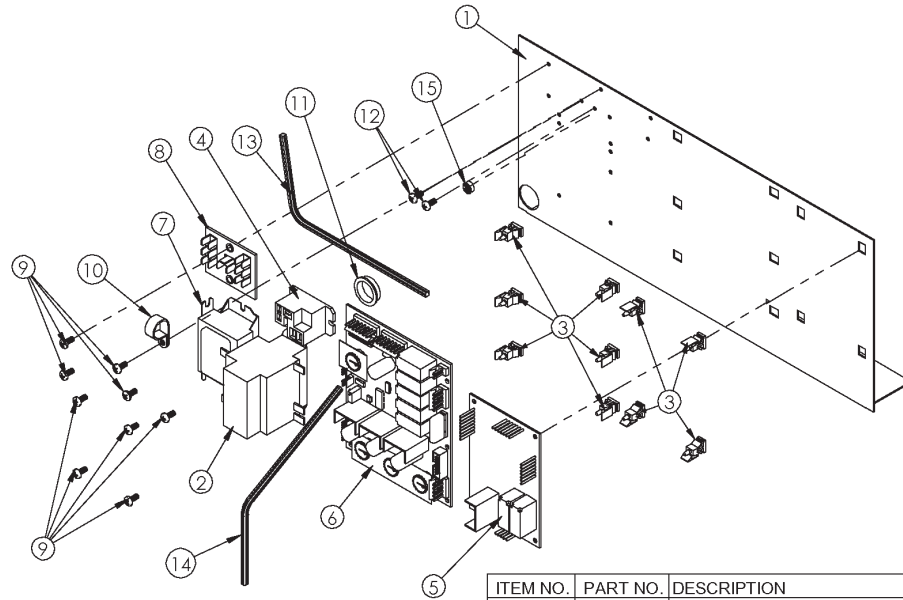

ITEM NO.	PART NO.	DESCRIPTION
1	62544	Bracket, Control Mtg PIC4
2	61481	Transformer,40VA 120 P 24/12 S
3	61266	STANDOFF, RVRS EDGEMOUNT
4	61131	Relay,12 vdc Coil
5	61632	Controller,PIC1
6	61800	Controller,Pic 3 Portion
7	61196	Ballast
8	61338	Terminal Board
9	61303	Screw, #8 x 3/8 black trilobe
10	60080	Clamp,5/8"Nylon **SC**
11	60394	Bushing,Snap-7/8"OD x 3/4"
12	61272	SCRW, #8X3/8 PH PN T/B ZNC/GN
13	61890	Harness, Control PIC2/3
14	62637	Harness, PIC4 Right Head
15	10073	Label, Ground Symbol
16	70425	TERM, 1/4M INS QD 18-22 GA
17	70426	TERM, 1/4F INS QD 18-22 GA

Lid

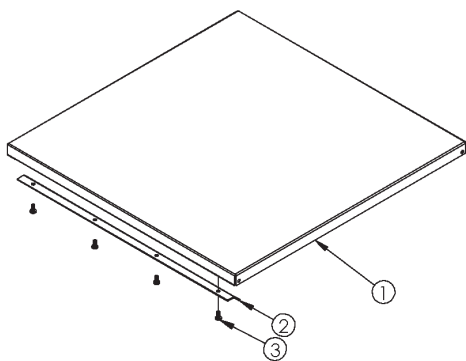

ITEM NO.	PART NO.	DESCRIPTION
1	62536	Panel, Lid PIC4
2	62704	Brace, Hopper Support PIC4
3	61303	Screw, #8 x 3/8 black trilobe

Base

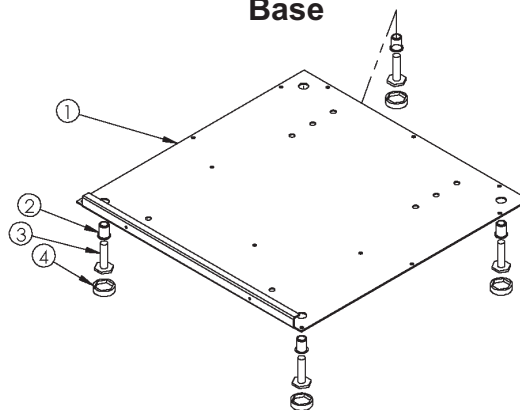

ITEM NO.	PART NO.	DESCRIPTION
1	62537	Panel, Base PIC4
2	60380	Rivnut, 3/8 - 16
3	61343	Leveler,Leg 3/8"-16 x 1.500"
4	61344	Pad,Leg 7/8"-1582-SOC-G

PIC43A Control Bracket Assembly

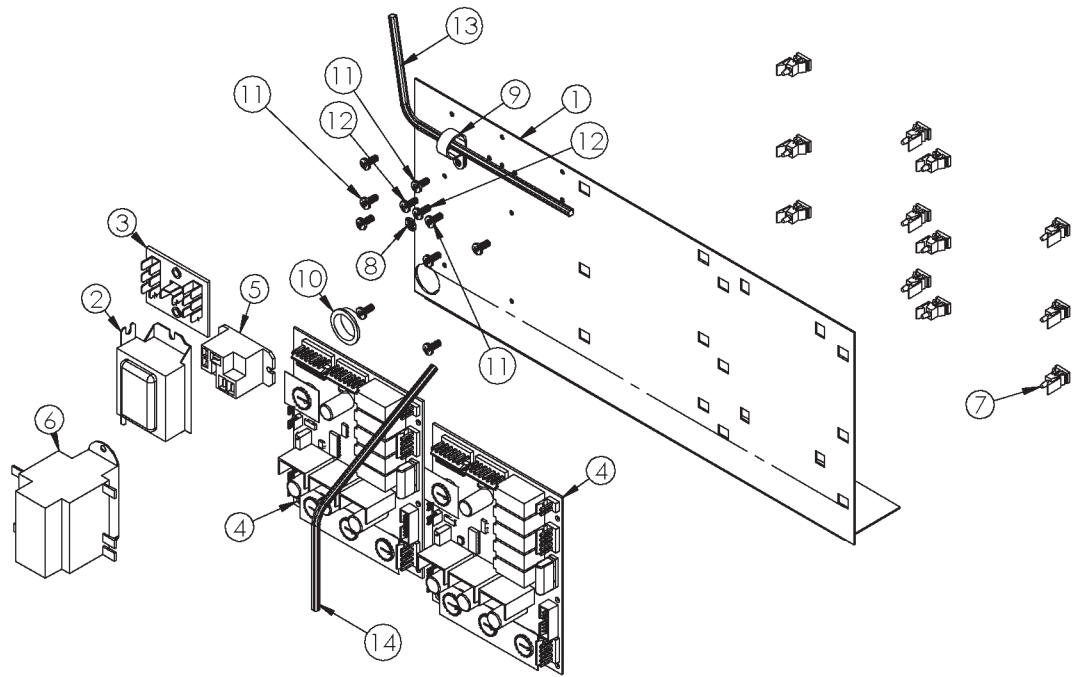

ITEM NO.	QTY.	PART NO.	DESCRIPTION
1	1	62737	Bracket, Control Mtg PIC43
2	1	61196	Ballast
3	1	61338	Terminal Board
4	2	61800	Controller, Pic 3 Portion
5	1	61131	Relay, 12 vdc Coil
6	1	61481	Transformer, 40VA 120 P 24/12 S
7	12	61266	STANDOFF, RVRS EDGEMOUNT
8	1	10073	Label, Ground Symbol
9	1	60080	Clamp, 5/8" Nylon **SC**
10	1	60394	Bushing, Snap-7/8"OD x 3/4"
11	9	61303	Screw, #8 x 3/8 black trilobe
12	2	61272	SCRW, #8X3/8 PH PN T/B ZNC/GN
13	1	61890	Harness, Control PIC2/3
14	1	62738	Harness, PIC43 Right Head

PIC 4 Hopper Bracket

For Soluble Non-Whipped Heads:
Remove #'s 9, 12, 15, 17, 42
Add #'s 10, 11, 43

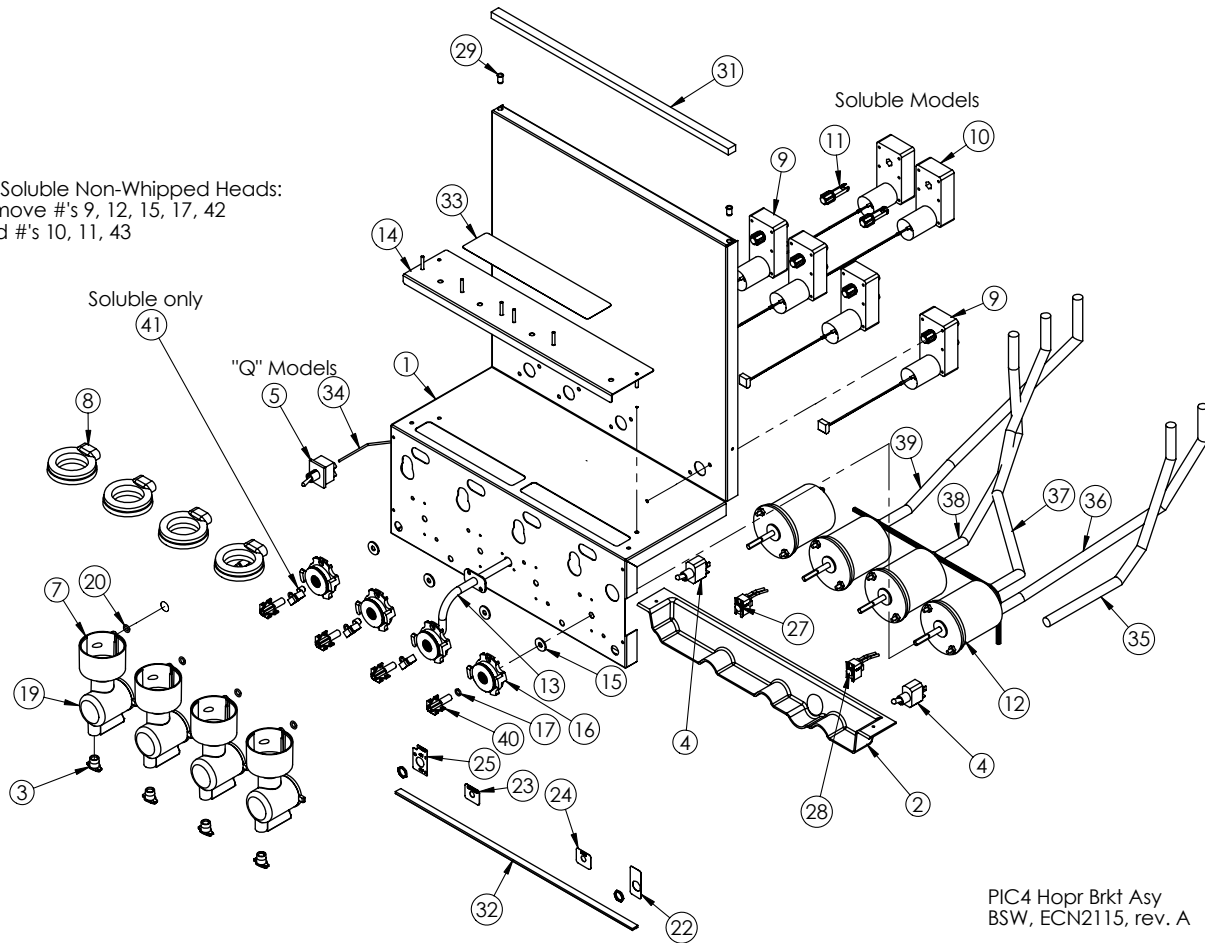

PIC4 Hopr Brkt Assy
BSW, ECN2115, rev. A

ITEM NO.	PART NO.	DESCRIPTION	ITEM NO.	PART NO.	DESCRIPTION
1	62533	Bracket, Hopper PIC4	23	61247	Label, Power On Light PIC
2	62754	Plenum, Steam PIC4	24	61248	Label, Ready Light PIC
3	61461	Button, Restrictor	25	61889	Label, PWR ON/OFF PIC
4	61847	Switch,Toggle-Spst	26	61303	Screw, #8 x 3/8 black trilobe
5	61466	Switch,Toggle 16 Amp Dpst	27	63496	Lamp Red w/ Leads
6	61266	STANDOFF, RVRS EDGEMOUNT	28	63495	Lamp Green w/ Leads
7	61221	Funnel, Whipper	29	60381	Rivnut, 6-32 ALS4-632-80
8	61255	SHROUD	30	61891	Harness, Hopper Brkt PIC2/3/4
9	100090	Gearbox Assy,24VDC,145RPM	31	61159-16-5	Seal, Closed Cell Foam 16.5"
10	65063	Motor, 24VDC,30 RPM,Sol	32	61352-16-5	Seal,Hopper Brkt - 16.5"
11	100089	Shaft,Gearbox,Componenti	33	61848	Decal, Do Not Pour
12	61116-01-1	Motor, Whipper 120V	34	61312	Wire, Jumper
13	61809	Spout, Water LCD/PIC4	35	71155-13-PIC4-R	Tubing, Silicone 5/16x1/2
14	62535	Plate, Cover Clean-Out Assy	36	71155-16-PIC4-W	Tubing, Silicone PIC4 Water
15	61334	Washer, Slinger	37	71155-16-PIC4-3	Tubing, Silicone 5/16x1/2
16	61523	Whipper Base Assy	38	71155-16-PIC4-2	Tubing, Silicone, 5/16x1/2
17	60741	O-Ring,2-014	39	71155-16-PIC4-L	Tubing, Silicone 5/16x1/2
18	07023-04	Screw,6-32x1/4 PH BD M/S SS	40	61458	Blade, Whipper
19	62395	Chamber, Whipper	41	63072	Plug,Whipper Base,Soluble
20	61127	O-RING,.335 ID X .079 CS			
21	61847-1	Nut, Switch, for 61847			
22	61242	Label, Flush On/Off			

PIC 4 Hopper

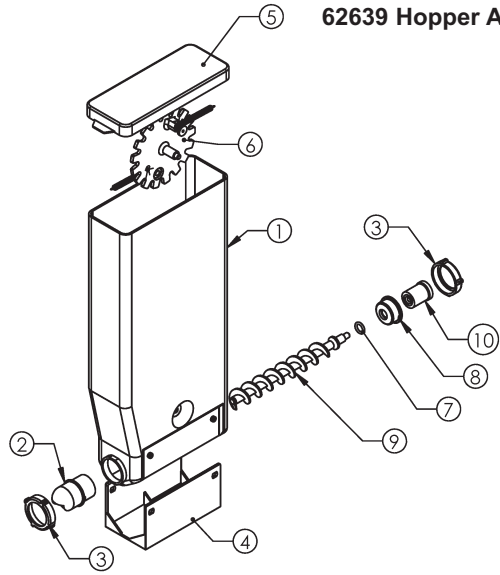

62639 Hopper Assy 5.5# PIC4 (use for sugar-based powders)

ITEM NO.	PART NO.	DESCRIPTION
1	100360	Hopper, 5.5# PIC4
2	100363	Sleeve,Hopr,Front,Flange PIC4/SP
3	100362	Nut,Hopr,Plast,PIC4/SP
4	100353	Base,Hopr,Metal Pin,PIC4/SP
5	100351	Lid,Hopr,PIC4/SP
6	100352	Pinwheel,Asy,Hopr,Compo,Thin
7	100139	O-Ring,,375x.563
8	100364	Bearing,Hopper
9	100355	Auger,Plastic,Componenti
10	100354	Coupling,Hopper,Long,PIC4

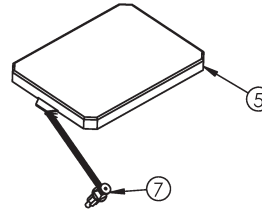

62640 Hopper Assy 11# PIC4 (use for sugar-based powders)

ITEM NO.	PART NO.	DESCRIPTION
1	100361	Hopper, 11#, PIC4
2	100363	Sleeve,Hopr,Front,Flange PIC4/SP
3	100362	Nut,Hopr,Plast,PIC4/SP
4	100359	Cradle,Hopper,Wide
5	100356	Lid, Wide Hopper,
6	100357	Pinwheel Assy, Large Hopper
7	100358	Gear,Pinwl,Asy,Hopr,Wide
8	100366-1	Flat Washer, Hopper
9	100365	Nut,8-32,Wing,Zinc
10	100139	O-Ring,,375x.563
11	100364	Bearing,Hopper
12	100355	Auger,Plastic,Componenti
13	100354	Coupling,Hopper,Long,PIC4

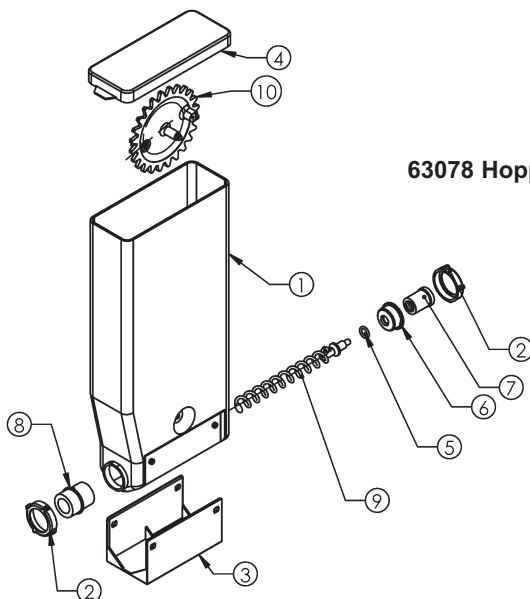
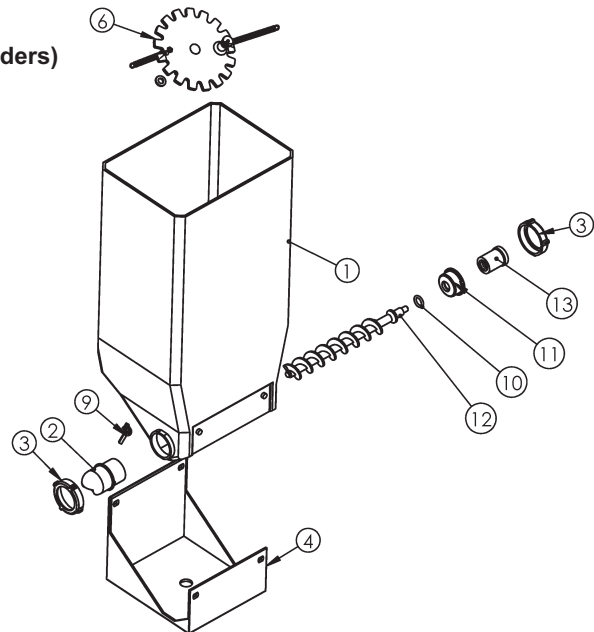

63078 Hopper Assy 5.5# PIC4 SOL (use for soluble coffee)

ITEM NO.	PART NO.	DESCRIPTION
1	100360	Hopper, 5.5# PIC4
2	100362	Nut,Hopr,Plast,PIC4/SP
3	100353	Base,Hopr,Metal Pin,PIC4/SP
4	100351	Lid,Hopr,PIC4/SP
5	100139	O-Ring,,375x.563
6	100364	Bearing,Hopper
7	100354	Coupling,Hopper,Long,PIC4
8	100564	Sleeve,Hopr,Front,Flange,17mm
9	100715	Auger,17mm Spring,SOL
10	100563	Pinwheel Assy,Hopr,17mm Spring

PIC 4 Tank Assembly

ITEM NO.	PART NO.	DESCRIPTION
1	61842	Cover, PIC Welded Tank Lid
2	61128	Probe, Thermistor, 12"
3	61626	Element,
4	61143	NUT, 1/8 NPT BRASS
5	61317	Enter Title
6	61108	PROBE, PIC
7	62305	T-STAT, HI TEMP LIMIT
8	71147	GROMMET, SILICONE WHT
9	05826,29.0	Tubing,3/8IDx1/8WL,Silicone
10	07327	Clamp,Hose,21/32ID,Heyco#2322
11	61280	Element,120V/1400W
12	61107	Element,240V/2500W
13	71261	NUT 8-32 SS WITH NYLON INSERT

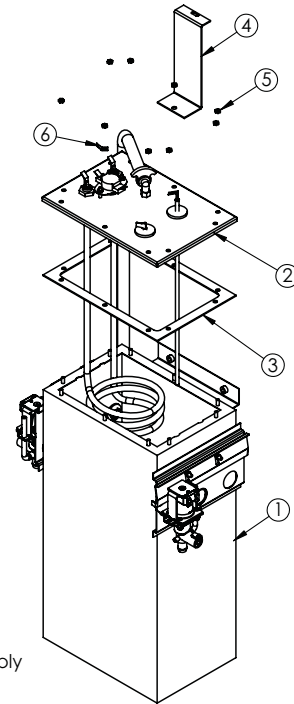
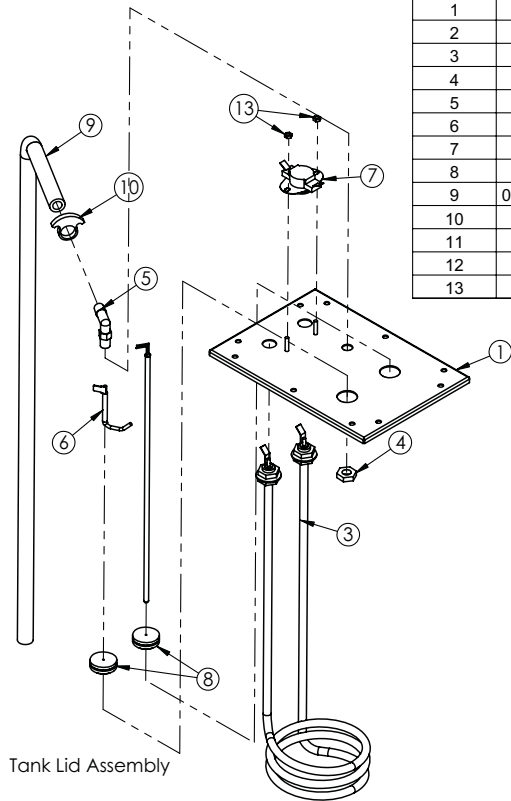

Tank Final Assembly

ITEM NO.	PART NO.	DESCRIPTION
1	62645	Tank Assy, PIC4
2	62646	Tank Lid Assy 120V, 1650W
3	61844	Gasket, PIC3 Welded Tank
4	62634	Bracket, Tank Brace Top PIC4
5	71261	NUT 8-32 SS WITH NYLON INSERT
6	70635	TERMINAL, 1/4-032 X 45DEG TAB

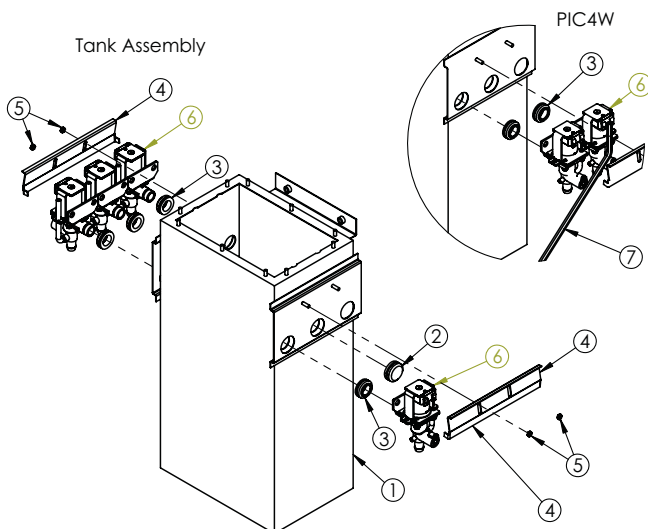

Drain/Fill Tubing Assembly

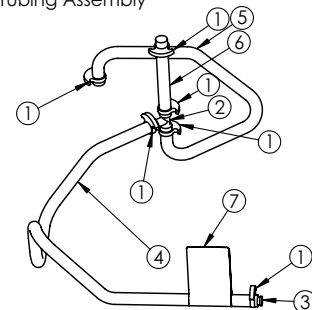

ITEM NO.	PART NO.	DESCRIPTION
1	62636	Tank, Water PIC4
2	61229	Grommet, Plug PIC units
3	61243	Grommet, Dump Valve
4	61137	Bracket, Dump Valve Brace
5	71261	NUT 8-32 SS WITH NYLON INSERT
6	63477	VALVE, DUMP 120V 60H DELTROL
7	62635	Harness, PIC4W Option

ITEM NO.	PART NO.	DESCRIPTION
1	07327	Clamp,Hose,21/32ID,Heyco#2322
2	61152	
3	61232	Plug,3/8 Barb
4	05826,29.00	Tubing,3/8IDx1/8WL,Silicone
5	05826,17.0	Tubing,3/8IDx1/8WL,Silicone
6	05826,5.0	Tubing,3/8IDx1/8WL,Silicone
7	61325	Decal,Tank Drain Hose

PIC 4 Door Assembly

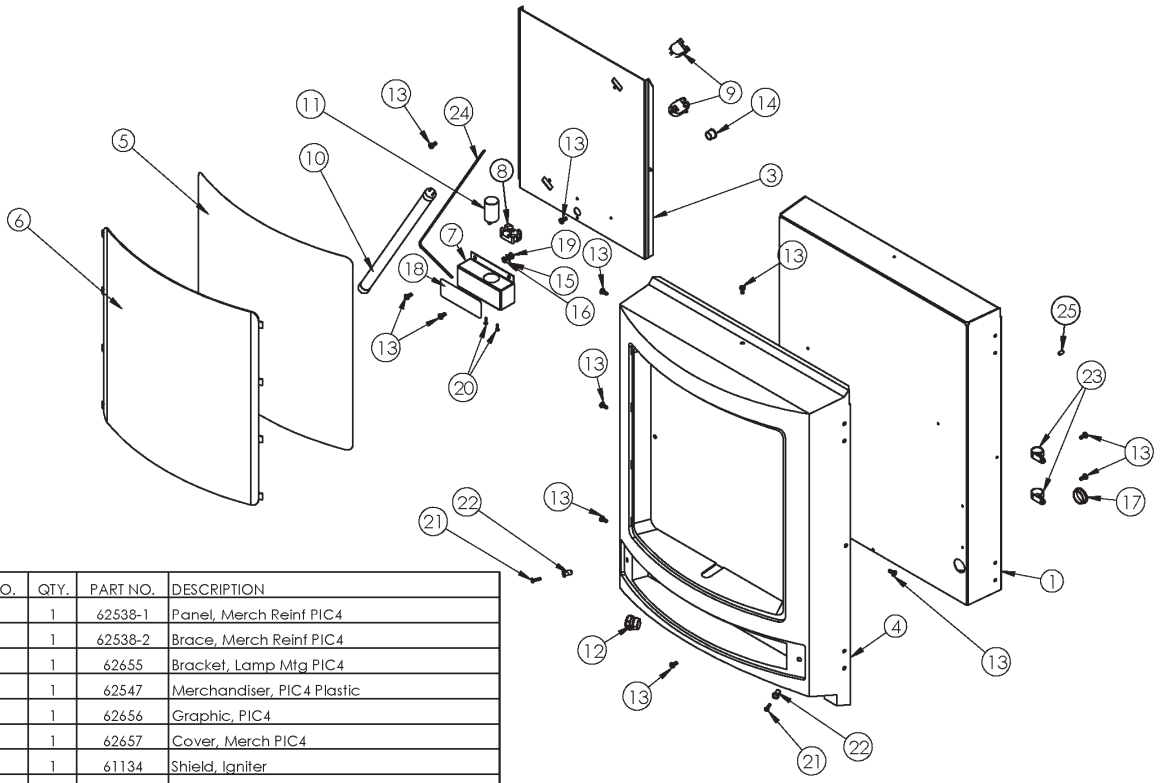

ITEM NO.	QTY.	PART NO.	DESCRIPTION
1	1	62538-1	Panel, Merch Reinf PIC4
2	1	62538-2	Brace, Merch Reinf PIC4
3	1	62655	Bracket, Lamp Mtg PIC4
4	1	62547	Merchandiser, PIC4 Plastic
5	1	62656	Graphic, PIC4
6	1	62657	Cover, Merch PIC4
7	1	61134	Shield, Igniter
8	1	62521	Base, Starter
9	2	61513	Holder, Mini Bi Pin
10	1	61118	Lamp, F8T5
11	1	61194	Starter, Bulb
12	1	61479	STRAIN RELIEF, HEYCO
13	12	61303	Screw, #8 x 3/8 black trilobe
14	1	07339-02	Bushing, Snap-1/2 Hey#SB-500-6
15	1	70635	TERMINAL, 1/4-032 X 45DEG TAB
16	1	61272	SCRW, #8X3/8 PH PN T/B ZNC/GN
17	1	60394	Bushing, Snap-7/8"OD x 3/4"
18	1	61327	Decal, Light Replace
19	1	61187	Washer, #8 Star Lock
20	2	62522	Screw, 4-36 x 3/8
21	2	61304	Screw, 6-32 x 1/2 PPH, SS
22	2	60122	Rivnut, 6-32
23	2	60080	Clamp, 5/8"Nylon **SC**
24	1	61136	Harness, Control PIC2/3
25	1	61440	CAP, #8 SCREW SOFT

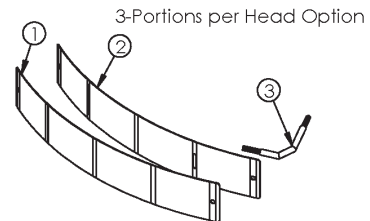

ITEM NO.	QTY.	PART NO.	DESCRIPTION
1	1	62734	Touchpad PIC43
2	1	62782	Panel, Switch PIC43
3	1	62736	Harness, Door PIC43

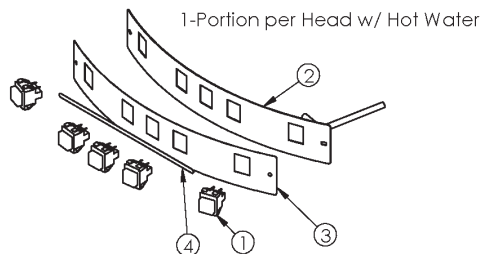

ITEM NO.	PART NO.	DESCRIPTION
1	61725	Switch, Dispensing
2	62660	Panel, Switch PIC4W
3	62661	Decal, Switch PIC4HW
4	61496	Decal, Auto Sw. panel Translation
5	62632	Harness, PIC4 Door

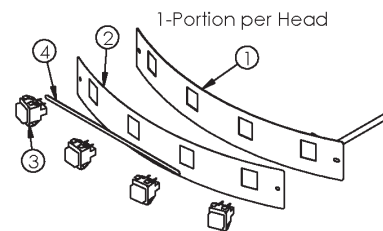

ITEM NO.	PART NO.	DESCRIPTION
1	62550	Panel, Switch PIC4
2	62551	Decal, Switch PIC4
3	61725	Switch, Dispensing
4	61496	Decal, Auto Sw. panel Translation
5	62632	Harness, PIC4 Door

PIC 4 Final Assembly

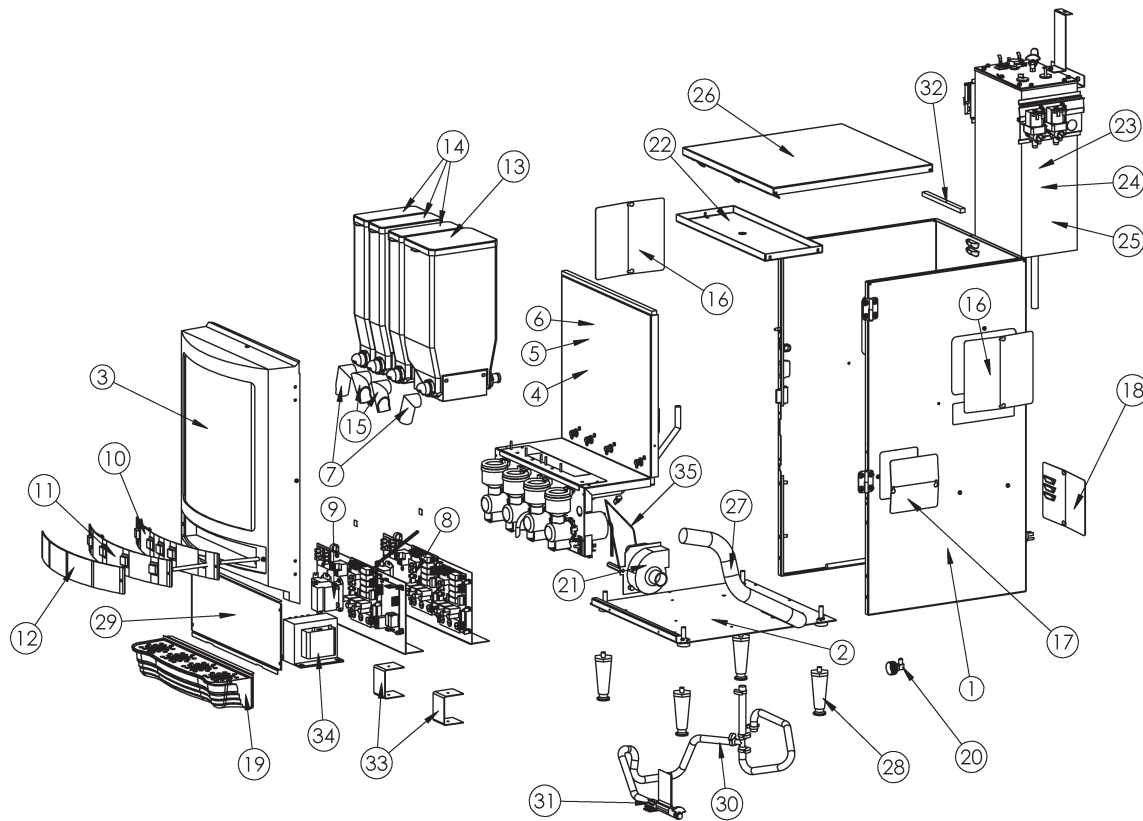

ITEM NO.	PART NO.	DESCRIPTION	WHERE USED
1	62708	Casing Assy,PIC4	
2	62647	Base Assy PIC4	
3	62643	Door Merch Assy,PIC4	
4	62644	Hopper Brkt Assy PIC4	PIC4
5	62720	Hopper Brkt Assy PIC4	PIC4W, Q, Z & SOL
6	62787	Hopper Brkt Assy PIC4	PIC4 Q & Z
7	100549	Elbow,Dispense,300deg	
8	62786	Control Brkt Assy PIC43	PIC 43
9	62650	Control Brkt Assy PIC4	PIC4
10	62659	Dispense Panel Assy	PIC 4W
11	62658	Dispense Panel Assy	PIC4
12	62790	Touchpad Asy PIC43A	PIC43A
13	62640	Hopper,11# Componenti	
14	62639	Hopper Assy,5,5#,PIC4,	
15	100548	Elbow,Dispense,240deg	
16	61423	Panel, Side Access DV	
17	61438	Panel,Steam Plenum-Black "IH"	
18	61141	Plate,Back Access	
19	62654	Drain Tray/Lower Splash Assy	
20	61237	Fitting,Assy,1/4 fL X 3/4 Hs, Brs	
21	62649	Blower Assembly 120V	
22	62633	Bracket, Tank Retaining PIC4	
23	62702	Tank Final Assy	PIC4 1650W
24	62789	Tank Final Assy	PIC4 Q & Z 25000W
25	62719	Tank Final Assy	PIC4W 1400W
26	62648	Lid Assy PIC4	
27	61123,24.0	TUBING, 1-1/4X24 LONG FLEX	
28	71256	Leg, 4" Adj 3/8"-16 Threads	
29	62534	Panel, Upper Splash PIC4	
30	62705	Tubing Assy,Drain,PIC2/3/4	
31	71160	Clip,Syphon Hose w/Blk Adhsv	
32	61159-7	Seal, Closed Cell Foam 7"	
33	63422	Bracket control support PIC4Z	PIC4 Z
34	63373	Transformer StepD 200VA 200/230/460-120	PIC4 Z
35	63430	Harness PIC 4 Z	PIC4 Z

PIC 5 Casing Assembly (Part # 62813)

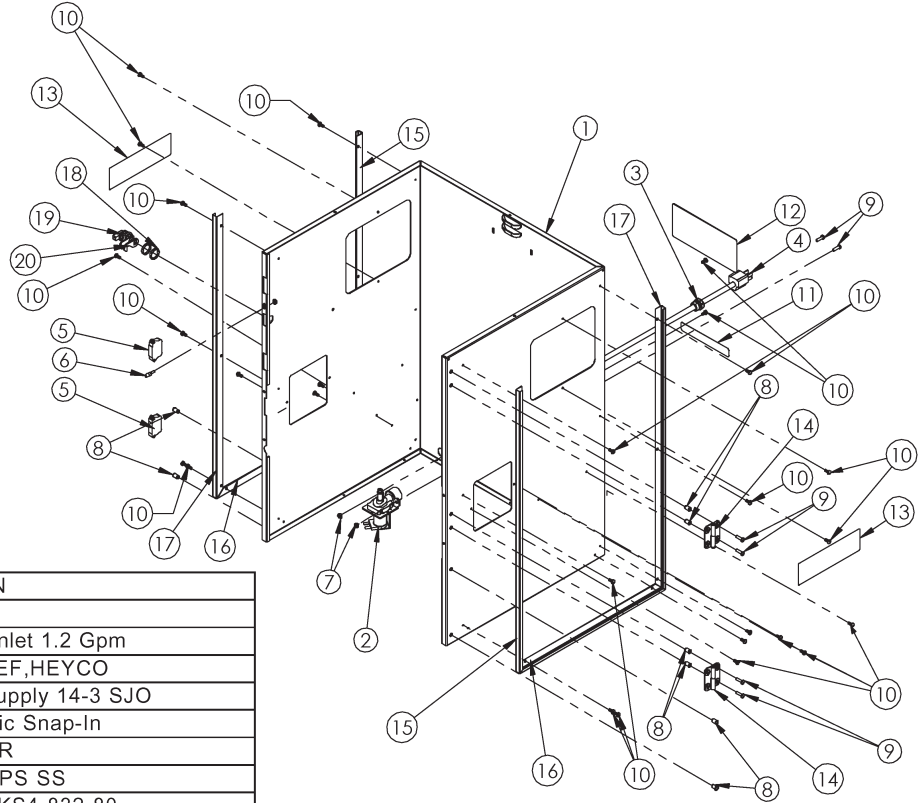

ITEM NO.	PART NO.	DESCRIPTION
1	62814	Casing, PIC5
2	63493	Valve, 120 V Inlet 1.2 Gpm
3	61479	STRAIN RELIEF, HEYCO
4	61530	Cord, Power Supply 14-3 SJO
5	61235	Latch, Magnetic Snap-In
6	61270	PIN, LOCATOR
7	71129	NUT, 8-32 KEPS SS
8	82096	Rivnut, 8-32 AKS4-832-80
9	61305	Screw, 8-32 x 5/8 black
10	61303	Screw, #8 x 3/8 black trilobe
11	61341	Decal, 1/4 Flr Wtr Connection
12	61319	Decal, Caution
13	61326	Decal, Caution Side PIC
14	61792	HINGE, PWDR COATED SS 2 LEAF
15	62815	Mural Rail PIC5, Left Rear
16	62817	Mural Rail PIC5, Bottom Horiz
17	62816	Mural Rail PIC5, Left Front
18	62219	Spacer, Key Lock
19	100115	Latch, Thumb
20	62556	Cam, Straight, Hook, 0.883

PIC 5 Base Assembly (Part # 62819)

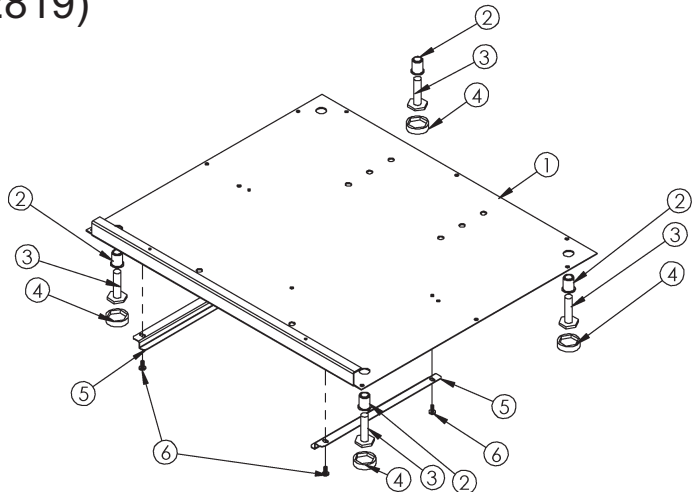

ITEM NO.	PART NO.	DESCRIPTION
1	62820	Panel, Base,
2	60380	Rivnut, 3/8 - 16
3	61343	Leveler, Leg 3/8"-16 x 1.500"
4	61344	Pad, Leg 7/8"-1582-SOC-G
5	63119	Rail, Drain Tray PIC5/6
6	61303	Screw, #8 x 3/8 black trilobe

PIC 5 Control Bracket Assembly (Part # 62974)

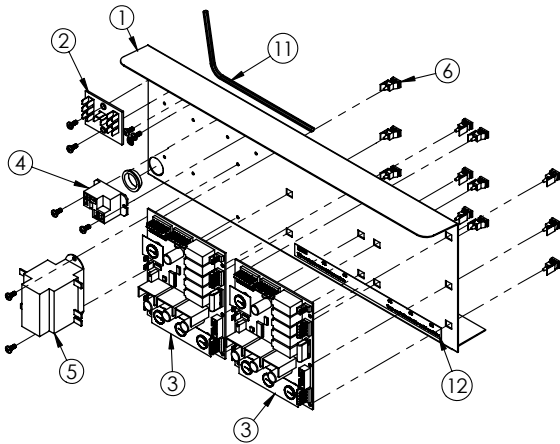

ITEM NO.	PART NO.	DESCRIPTION
1	62849	Bracket, Control Mtg PIC5 No Display
2	61338	Terminal Board
3	61800	Controller,Pic 3 Portion
4	61131	Relay,12 vdc Coil
5	61481	Transformer,40VA 24/12S
6	61266	STANDOFF, RVRS EDGEMOUNT
7	10073	Label, Ground Symbol
8	60394	Bushing,Snap-7/8"OD x 3/4"
9	61303	Screw, #8 x 3/8 black trilobe
10	61272	SCRW, #8X3/8 PH PN T/B ZNC/GN
11	62890	Harness, Chassis PIC5/6
12	62928	DECAL, CONTROLLER PIC5/6

PIC 5 Lid Assembly (Part # 62810)

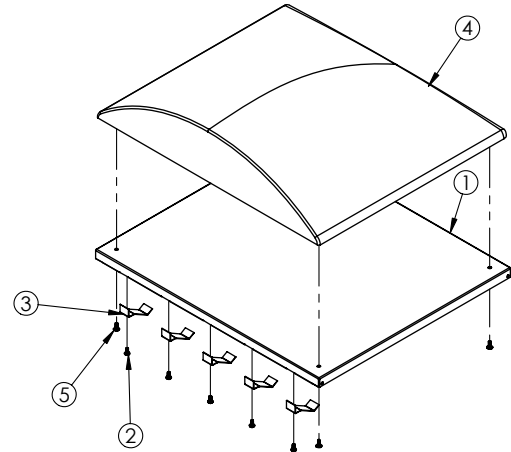

ITEM NO.	PART NO.	DESCRIPTION
1	62811	Panel, Lid,
2	61303	Screw, #8 x 3/8 black trilobe
3	61217	Spring, Hopper Retaining
4	62812	Flashing Top PIC5
5	86877	SCRW, #8X1/2 PH TR HD T/AB ZNC

PIC 5 Door Assembly (Part # 63060)

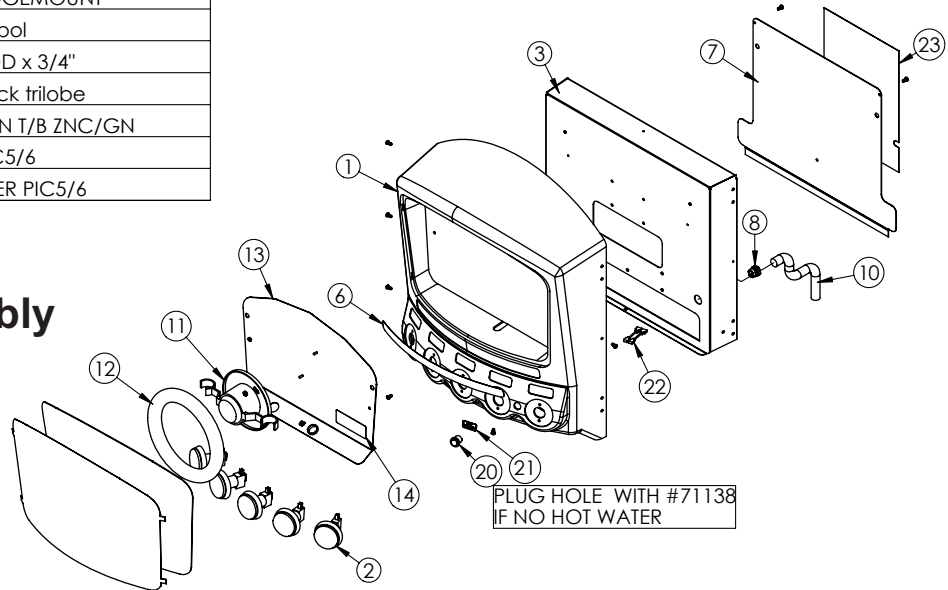

ITEM NO.	PART NO.	DESCRIPTION	ITEM NO.	PART NO.	DESCRIPTION
1	63482	Door Plastic PIC5W w hole	13	63061	Bracket, Circle Lamp
2	62915	Switch, Dispns PIC5/6 No Wafer	14	61327	Decal, Light Replace
3	62884	Door Brkt Wldmt,	15	71129	NUT, 8-32 KEPS SS
4	62904	Cover,PIC5 Graphic	16	60394	Bushing,Snap-7/8"OD x 3/4"
5	62905	Graphic,PIC5	17	61272	SCRW, #8X3/8 PH PN T/B ZNC/GN
6	62856	Decal, 2/3 Full PIC5/6	18	61187	Washer, #8 Star Lock
7	62847	Panel, Dispense Switch Cvr,	19	70635	TERMINAL, 1/4-032 X 45DEG TAB
8	61479	STRAIN RELIEF,HEYCO	20	63479	Switch Hot Water PIC5W
9	61303	Screw, #8 x 3/8 black trilobe	21	63481	Label "Hot Water" PIC5W
10	62889	Harness, Door PIC5/6	22	63480	Harness PIC5W Jumper
11	62937	Fixture,Circle Fluor w Lamp 22W	23	61451	Decal, Door Inner PIC
12	62973	Bulb Circle 22W			

PIC 5 Hopper Bracket Assembly (Part # 62850)

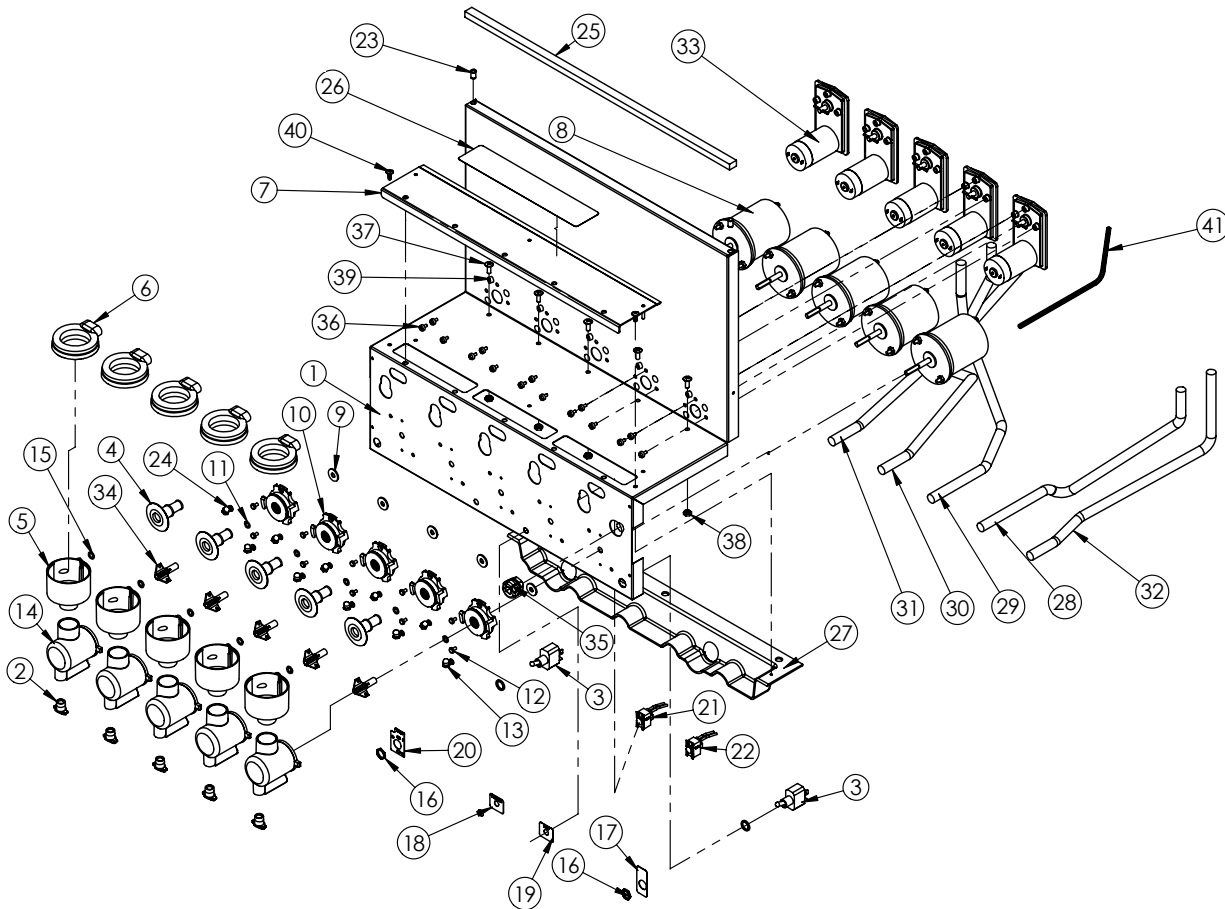

ITEM NO.	PART NO.	DESCRIPTION	ITEM NO.	PART NO.	DESCRIPTION
1	62851	Bracket, Hopper PIC5	23	60381	Rivnut, 6-32 ALS4-632-80
2	61461	Button, Restrictor	24	61250	Washer, #8 Split Lock
3	61847	Switch,Toggle-Spst	25	61159-19-5	Seal, Closed Cell Foam 16.5"
4	61226	Funnel, Disconnect	26	61848	Decal, Do Not Pour
5	61221	Funnel Whipper	27	62825	Plenum, Steam PIC5
6	61255	SHROUD	28	71155-15-b	Tubing, Silicone 5/16x1/2
7	62823	Plate, Cover Plenum,	29	71155-16-a	Tubing, Silicone 5/16x1/2
8	61116-01-1	Motor, Whipper 120V	30	71155-16-b	Tubing, Silicone, 5/16x1/2
9	61334	Washer, Slinger	31	71155-16-c	Tubing, Silicone 5/16x1/2
10	61523	Whipper Base Assy	32	71155-15-a	Tubing, Silicone 5/16x1/2
11	60741	O-Ring,2-014	33	61618	Motor,24VDC,Auger,145 RPM
12	07023-04	Screw,6-32x1/4 PH BD M/S SS	34	61458	Blade, Whipper
13	61339	8-32 UNF S.S. ACORN NUT	35	61480	STRAIN RELIEF,HEYCO
14	62395	Chamber, Whipper	36	61353	Screw,8-32 X 1/4" PH PN 18-8 SS
15	61127	O-RING,.335 ID X .079 CS	37	61236	SCRW, 10-32X1/2 PH TR SS
16	61847-1	Nut, Switch, for 61847	38	63068	NUT, 10-32 ESNA SS
17	61242	Label, Flush On/Off	39	61228	Spacer, NYL HEY #334 SPU98
18	61247	Label, Power On Light PIC	40	86877	SCRW, #8X1/2 PH TR HD T/AB ZNC
19	61248	Label, Ready Light PIC	41	62891	Harness, Hopper Brkt PIC5/6
20	61889	Label, PWR ON/OFF PIC	43	61264	Plug, 3/16" Hole
21	63496	Lamp Red w/ Leads			
22	63495	Lamp Green w/ Leads			

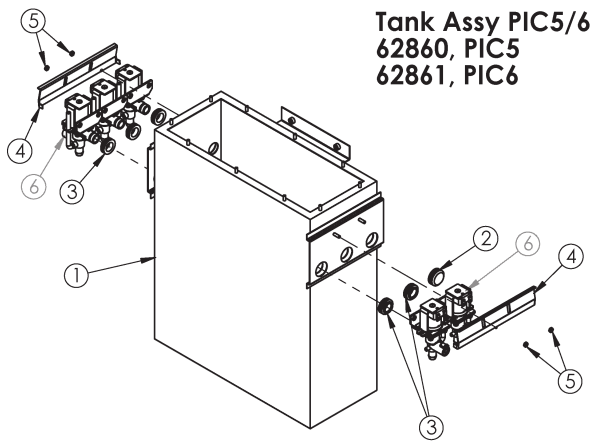

Tank Assy PIC5/6
62860, PIC5
62861, PIC6

ITEM NO.	PART NO.	DESCRIPTION
1	62853	Tank, Water PIC5/6, 5 GAL
2	61229	Grommet, Plug PIC units
3	61243	Grommet, Dump Valve
4	61137	Bracket, Dump Valve Brace
5	71261	NUT 8-32 SS WITH NYLON INSERT
6	63477	VALVE, DUMP 120V 60H DELTROL

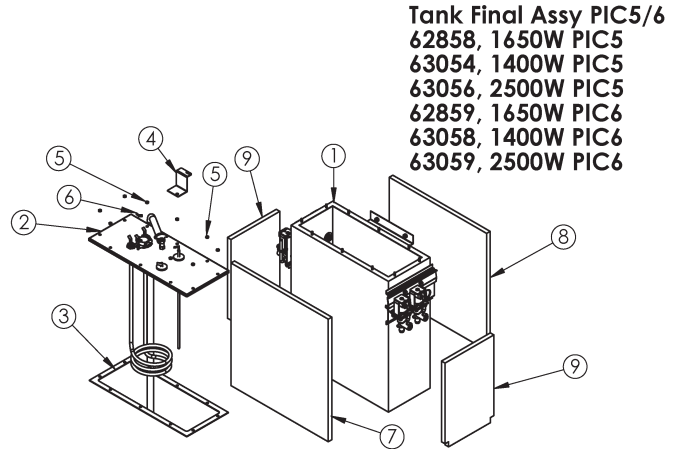

Tank Final Assy PIC5/6
62858, 1650W PIC5
63054, 1400W PIC5
63056, 2500W PIC5
62859, 1650W PIC6
63058, 1400W PIC6
63059, 2500W PIC6

ITEM NO.	PART NO.	DESCRIPTION
1	62860	Tank Assy, PIC
2	62862	Tank Lid Assy PIC5/6
3	62855	Gasket, PIC5/6 Welded Tank
4	62829	Bracket, Tank Brace Top PIC5
5	71261	NUT 8-32 SS WITH NYLON INSERT
6	70635	TERMINAL, 1/4-032 X 45DEG TAB
7	62842	Insulation, Tank Front PIC5
8	62844	Insulation, Tank Rear PIC5
9	62843	Insulation, Tank Side PIC5

62836 - Tubing Asy, Drain, PIC5 /6

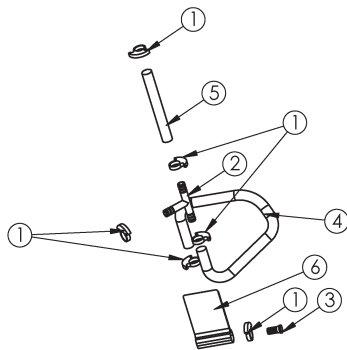

ITEM NO.	PART NO.	DESCRIPTION
1	07327	Clamp, Hose, 21/32ID, Heyco #2322
2	61152	Tee, 7/16" Barbed
3	61232	Plug, 3/8 Barb
4	05826, 17.0 PIC5	Tubing, 3/8ID x 1/8WL, Silicone
5	05826, 5.0	Tubing, 3/8ID x 1/8WL, Silicone
6	61325	Decal, Tank Drain Hose

Tank Lid Assy PIC5/6
62862 - 120V, 1650W
63055 - 120V, 1400W
63057 - 120/240V, 2500W

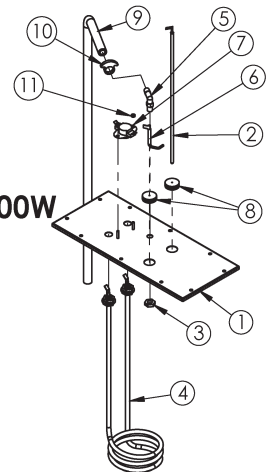

Heating Element (#4):
61626 - 120V, 1650W
61280 - 120V, 1400W
61107 - 120/240V, 2500W

ITEM NO.	PART NO.	DESCRIPTION
1	62854	Cover, Tank Lid PIC5/6
2	61128	Probe, Thermistor, 12"
3	61143	NUT, 1/8 NPT BRASS
4	61626	Element,
5	61317	Enter Title
6	61108	PROBE, PIC
7	62305	T-STAT, HI TEMP LIMIT
8	71147	GROMMET, SILICONE WHT
9	05826, 29.0	Tubing, 3/8ID x 1/8WL, Silicone
10	07327	Clamp, Hose, 21/32ID, Heyco #2322
11	71261	NUT 8-32 SS WITH NYLON INSERT

PIC 5 Final Assembly

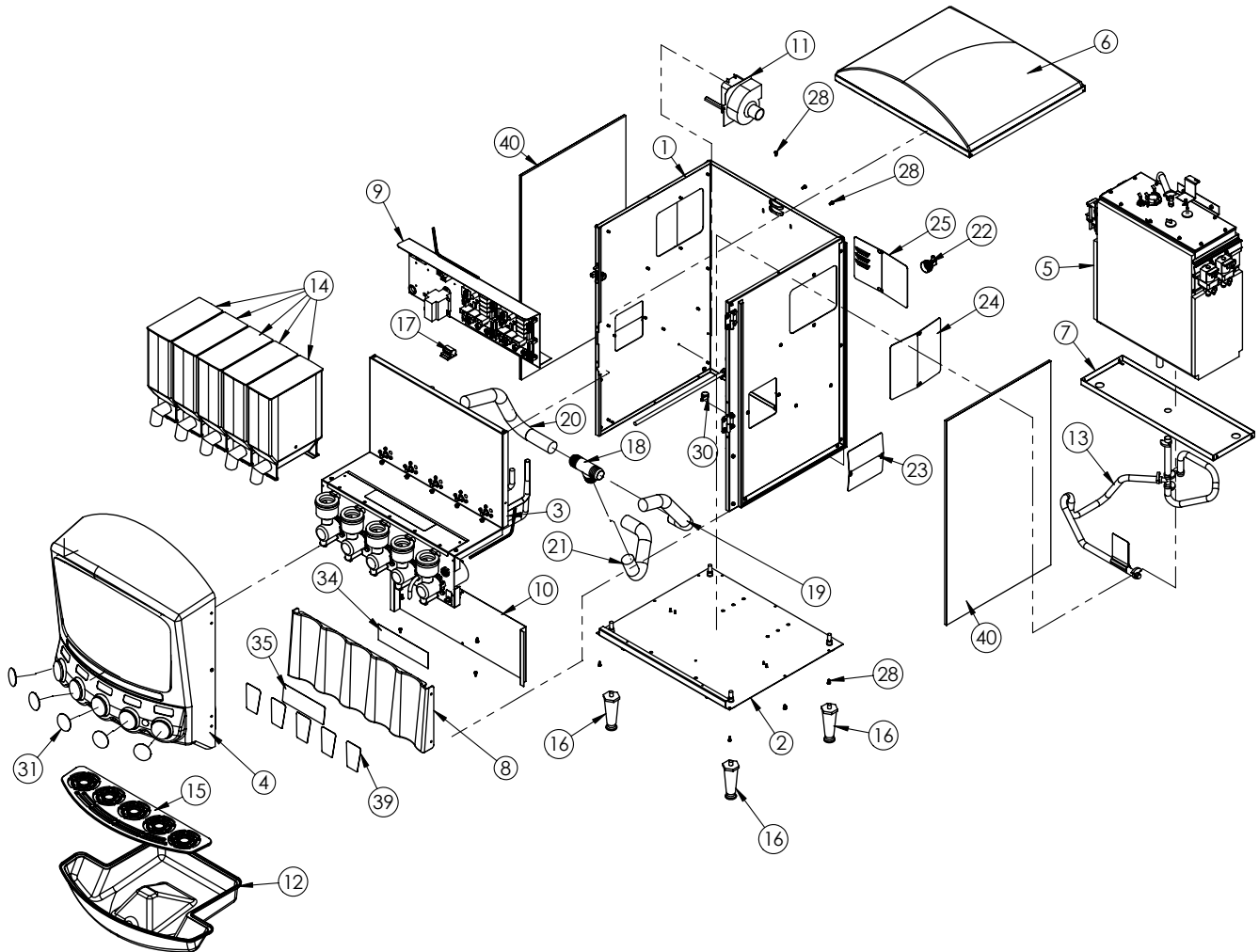

ITEM NO.	PART NO.	DESCRIPTION	ITEM NO.	PART NO.	DESCRIPTION
1	62813	Casing Assy,PIC	22	61237	Fitting,Assy,1/4 fl X 3/4 Hs, Brs
2	62819	Base Assy PIC6	23	61438	Panel,Steam Plenum-Black *IH*
3	63485	Hopper Brkt Asy PIC5	24	61423	Panel, Side Access DV
4	63060	Door Asy PIC5	25	61141	Plate,Back Access
5	62858	Tank Final Assy	26	61305	Screw, 8-32 x 5/8 black
6	62810	Lid Assy PIC6	27	71129	NUT, 8-32 KEPS SS
7	62830	Bracket, Tank Retaining,	28	61303	Screw, #8 x 3/8 black trilobe
8	62832	Splash Panel Plastic PIC	29	61304	Screw,6-32 x 1/2 PPH,SS
9	62974	Control Brkt Assy PIC6	30	60080	Clamp,5/8"Nylon **SC**
10	62831	Splash Panel,	31	62914	Button, Swch PIC5/6 w/ Art
11	62802	Blower Assembly 120V	32	61440	CAP, #8 SCREW SOFT
12	62833	Tray, Drain PIC5	33	61834	Decal, FLVR Strip PIC
13	62836	Tubing Asy,Drain,PIC5	34	100268	Decal,Caution,Behind Drip Tray
14	61372	Hopper Asy PIC Single Pinw	35	62981	Decal, Front Warning PIC
15	62921	Grid Drain PIC5	36	61146	Instr, Manual PIC Domestic
16	71256	Leg, 4" Plastic	37	00800	Label,Serial Number,Name Plate
17	71160	Clip,Syphon Hose w/Blk Adhsv	38	61463	Tag, Instalation
18	62835	Tee, 1.25"	39	62929	Decal, Cup PIC5/6
19	62845-2	TUBING, 1-1/4X14 LONG FLEX	40	62992	Mural Assy Side PIC5-6
20	62845-1	TUBING, 1-1/4X14 LONG FLEX			
21	62845-3	TUBING, 1-1/4X14 LONG FLEX			

PIC 6 Casing Assembly (Part # 62872)

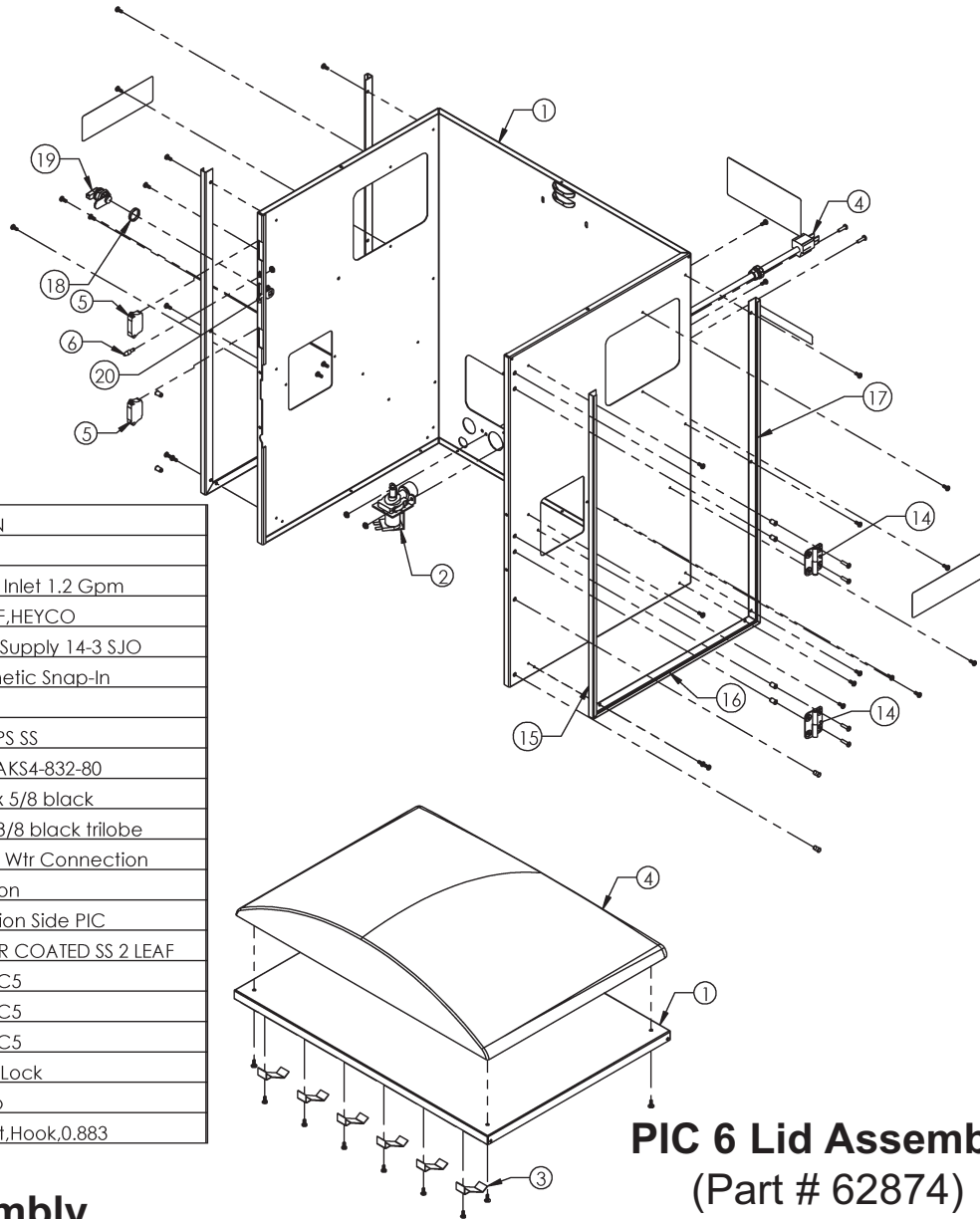

ITEM NO.	PART NO.	DESCRIPTION
1	62882	Casing,
2	63493	Valve, 120 V Inlet 1.2 Gpm
3	61479	STRAIN RELIEF, HEYCO
4	61530	Cord, Power Supply 14-3 SJO
5	61235	Latch, Magnetic Snap-In
6	61270	Pin, Locator
7	71129	NUT, 8-32 KEPS SS
8	82096	Rivnut, 8-32 AKS4-832-80
9	61305	Screw, 8-32 x 5/8 black
10	61303	Screw, #8 x 3/8 black trilobe
11	61341	Decal, 1/4 Fir Wtr Connection
12	61319	Decal, Caution
13	61326	Decal, Caution Side PIC
14	61792	HINGE, PWDR COATED SS 2 LEAF
15	62815	Mural Rail PIC5
16	62817	Mural Rail PIC5
17	62816	Mural Rail PIC5
18	62219	Spacer, Key Lock
19	100115	Latch, Thumb
20	62556	Cam, Straight, Hook, 0,883

PIC 6 Lid Assembly (Part # 62874)

PIC 6 Base Assembly (Part # 62876)

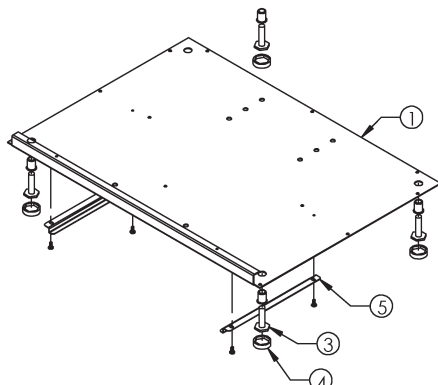

ITEM NO.	PART NO.	DESCRIPTION
1	62878	Panel, Lid,
2	61303	Screw, #8 x 3/8 black trilobe
3	61217	Spring, Hopper Retaining
4	62869	Flashing Top PIC6
5	86877	SCRW, #8X3/8 PH PN T/B ZNC/GN

ITEM NO.	PART NO.	DESCRIPTION
1	62877	Panel, Base,
2	60380	Rivnut, 3/8 - 16
3	61343	Leveler, Leg 3/8"-16 x 1.500"
4	61344	Pad, Leg 7/8"-1582-SOC-G
5	63119	Rail, Drain Tray PIC5/6
6	61303	Screw, #8 x 3/8 black trilobe

PIC 5/6 Control Bracket Assembly (Part # 62848)

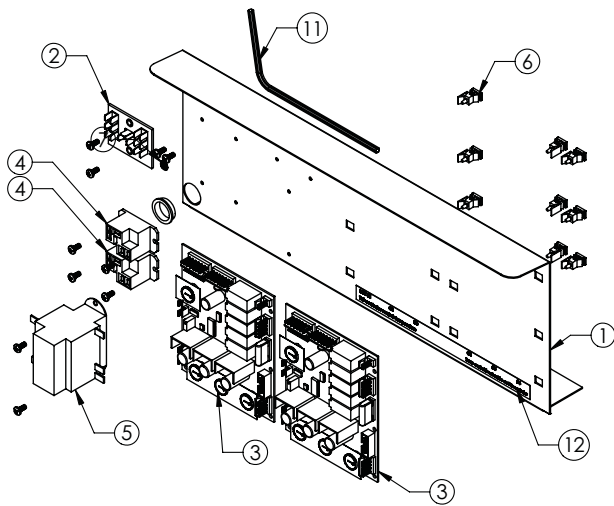

ITEM NO.	PART NO.	DESCRIPTION
1	62849	Bracket, Control Mtg PIC5 No Display
2	61338	Terminal Board
3	61800	Controller,Pic 3 Portion
4	61131	Relay,12 vdc Coil
5	61481	Transformer,40VA 24/12S
6	61266	STANDOFF, RVRS EDGEMOUNT
7	10073	Label, Ground Symbol
8	60394	Bushing,Snap-7/8"OD x 3/4"
9	61303	Screw, #8 x 3/8 black trilobe
10	61272	SCRW, #8X3/8 PH PN T/B ZNC/GN
11	62890	Harness, Chassis PIC5/6
12	62928	DECAL, CONTROLLER PIC5/6

PIC 6 Door Assembly (Part # 62875)

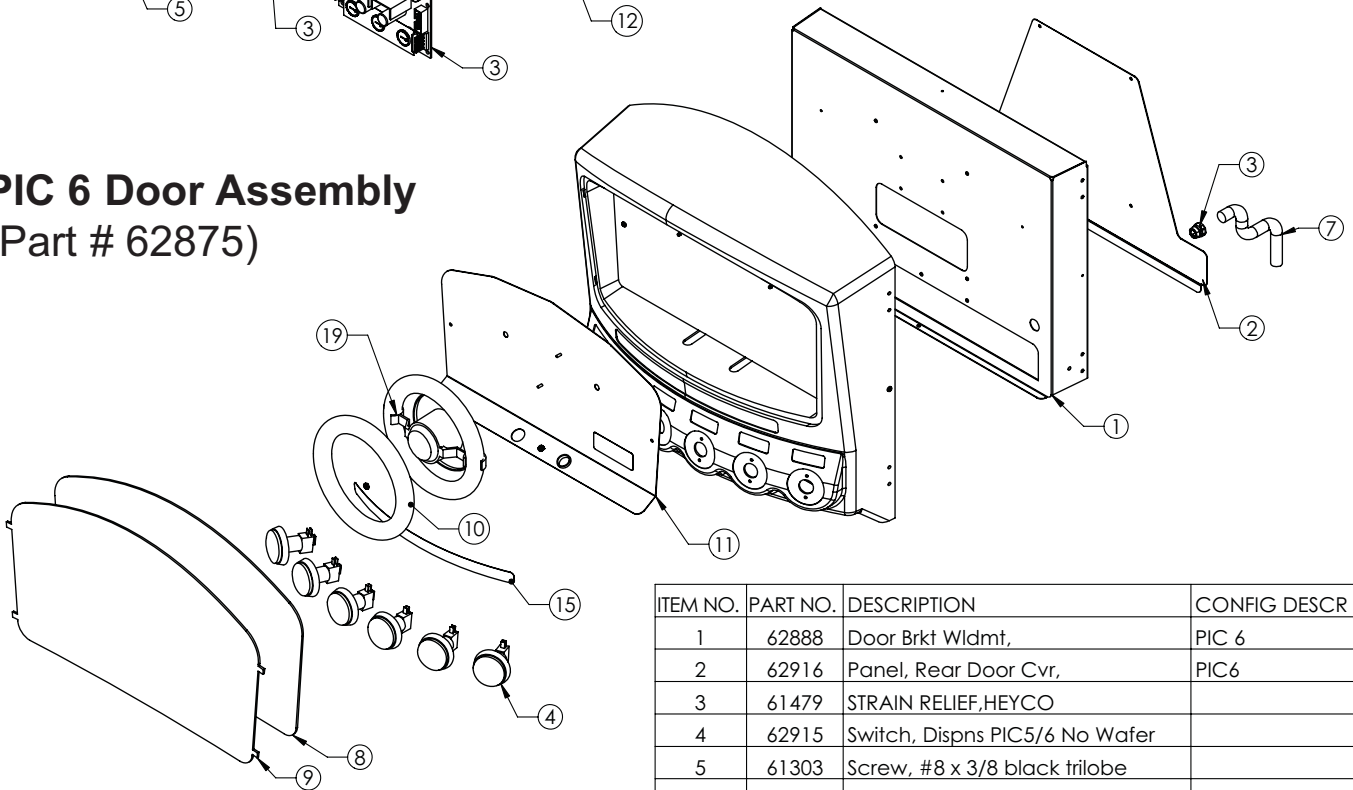

ITEM NO.	PART NO.	DESCRIPTION	CONFIG DESCR
1	62888	Door Brkt Wldmt,	PIC 6
2	62916	Panel, Rear Door Cvr,	PIC6
3	61479	STRAIN RELIEF,HEYCO	
4	62915	Switch, Dispns PIC5/6 No Wafer	
5	61303	Screw, #8 x 3/8 black trilobe	
6	62910	Merchandiser PIC6 Plastic	
7	62889	Harness, Door PIC5/6	
8	62919	Graphic PIC6	
9	62920	Graphic PIC6	Cover
10	62973	Bulb Circle 22W	
11	62936	Bracket, Circle Lamp	PIC6
12	61272	SCRW, #8X3/8 PH PN T/B ZNC/GN	
13	61187	Washer, #8 Star Lock	
14	70635	TERMINAL, 1/4-032 X 45DEG TAB	
15	62856	Decal, 2/3 Full PIC5/6	
16	60394	Bushing,Snap-7/8"OD x 3/4"	
17	71129	NUT, 8-32 KEPS SS	
18	70426	TERM, 1/4F INS QD 18-22 GA	
19	62937	Fixture,Circle Fluor w Lamp 22W	
20	61327	Decal, Light Replace	

PIC 6 Hopper Bracket Assembly

(Part # 62863)

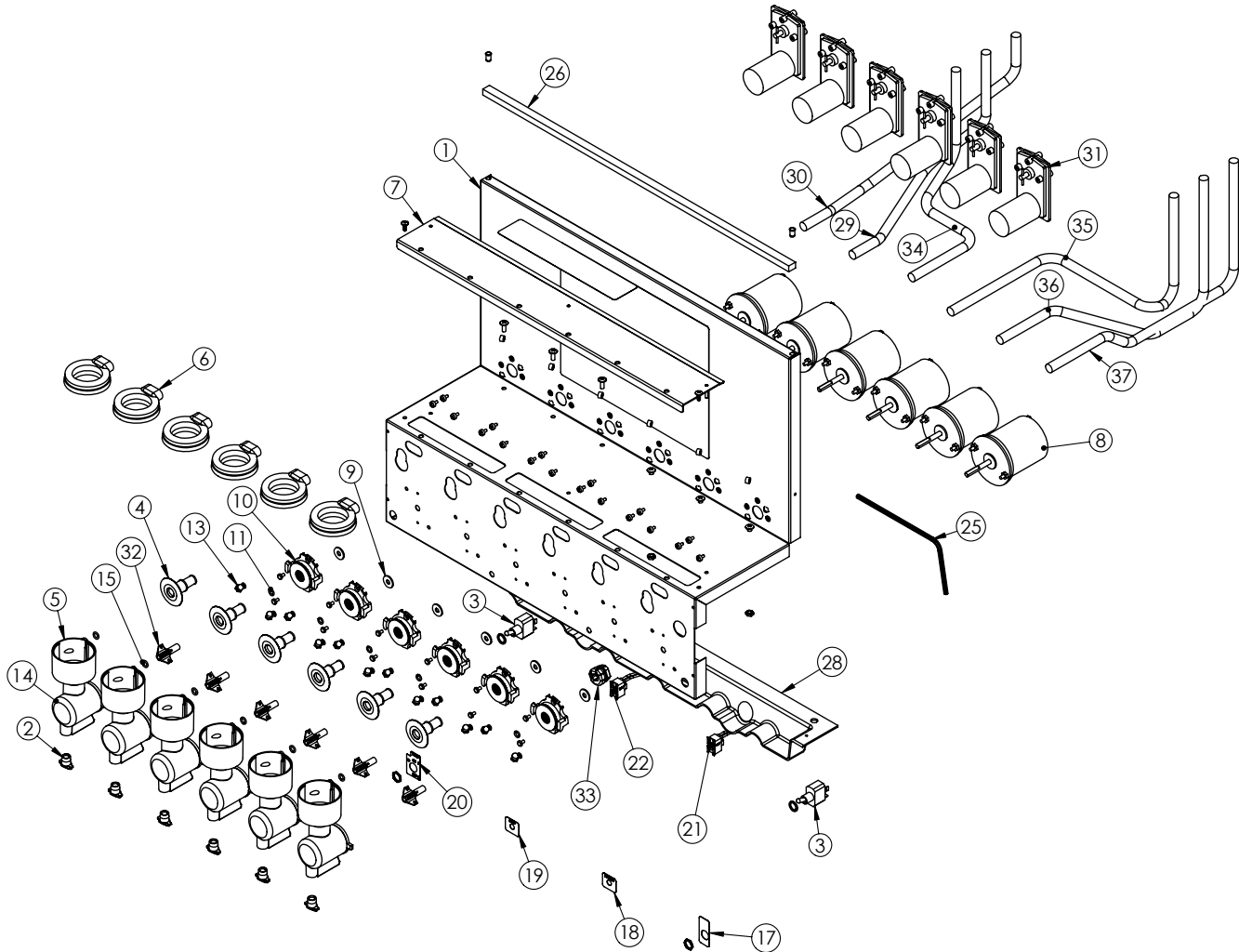

ITEM NO.	PART NO.	DESCRIPTION	ITEM NO.	PART NO.	DESCRIPTION
1	62864	Bracket, Hopper PIC6	24	61250	Washer, #8 Split Lock
2	61461	Button, Restrictor	25	62891	Harness, Hopper Brkt PIC5/6
3	61847	Switch,Toggle-Spst	26	61159-23.5	Seal, Closed Cell Foam 16.5"
4	61226	FTG, FUNNEL DISCONNECT	27	61848	Decal, Do Not Pour
5	61221	Funnel Whipper	28	62865	Plenum, Steam PIC6
6	61255	SHROUD	29	71155-16-PIC6-2	Tubing, Silicone, 5/16x1/2
7	62879	Plate, Cover Plenum,	30	71155-16-PIC6-L	Tubing, Silicone 5/16x1/2
8	61116-01-1	Motor, Whipper 120V	31	61618	MOTOR,24VDC, 145RPM
9	61334	Washer, Slinger	32	61458	Blade, Whipper
10	61523	Whipper Base Assy	33	61480	STRAIN RELIEF,HEYCO
11	60741	O-Ring,2-014	34	71155-16-PIC6-3	Tubing, Silicone, 5/16x1/2
12	07023-04	Screw,6-32x1/4 PH BD M/S SS	35	71155-16-PIC6-4	Tubing, Silicone, 5/16x1/2
13	61339	8-32 UNF S.S. ACORN NUT	36	71155-16-PIC6-5	Tubing, Silicone, 5/16x1/2
14	62395	Chamber, Whipper	37	71155-16-PIC6-6	Tubing, Silicone, 5/16x1/2
15	61127	O-RING,.335 ID X .079 CS	38	86877	SCRW, #8X3/8 PH PN T/B ZNC/GN
16	61847-1	Nut, Switch, for 61847	39	61353	Screw,8-32 X 1/4" PH PN 18-8 SS
17	61242	Label, Flush On/Off	40	61228	Spacer, NYL HEY #334 SPU98
18	61247	Label, Power On Light PIC	41	61236	SCRW, 10-32X1/2 PH TR SS
19	61248	Label, Ready Light PIC	42	63068	NUT, 10-32 ESNA SS
20	61889	Label, PWR ON/OFF PIC	43	61847-2	Nut Round for Switch
21	63496	Lamp Red w/ Leads	44	61452	Decal, Cleaning Instr 5# HPR
22	63495	Lamp Green w/ Leads	45	61264	PLUG, 3/16 HOLE FAS
23	60381	Rivnut, 6-32 ALS4-632-80			

PIC 6 Final Assembly

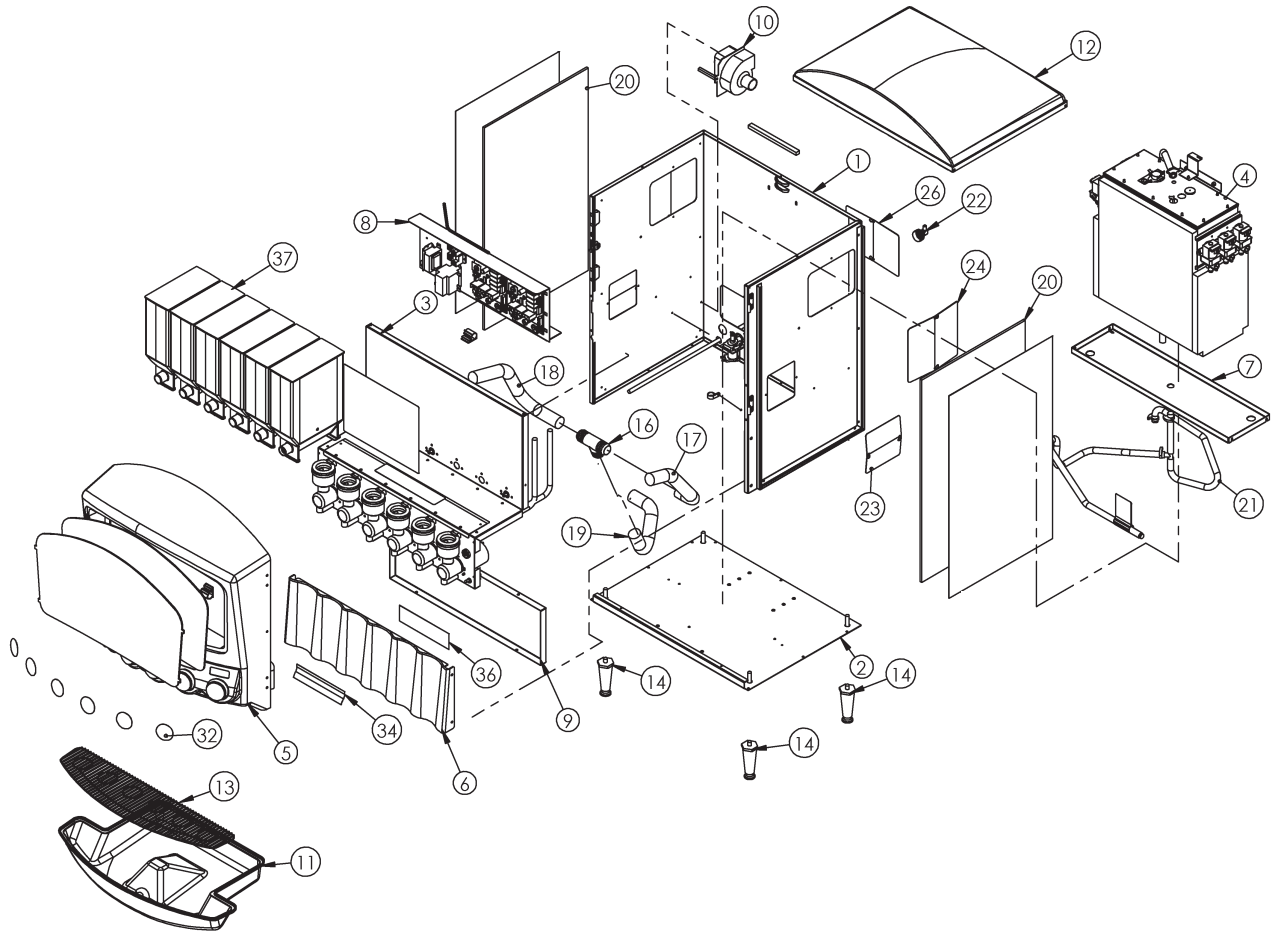

ITEM NO.	PART NO.	DESCRIPTION	ITEM NO.	PART NO.	DESCRIPTION
1	62872	Casing Assy,PIC6	23	61438	Panel,Steam Plenum-Black *IH*
2	62819	Base Assy PIC5	24	61423	Panel, Side Access DV
3	62863	Hopper Brkt Assy PIC6	25	61159-7	Seal, Closed Cell Foam 7"
4	62859	Tank Final Assy	26	61141	Plate,Back Access
5	62875	Door Asy PIC5	27	61305	Screw, 8-32 x 5/8 black
6	62870	Splash Panel Plastic PIC	28	71129	NUT, 8-32 KEPS SS
7	62830	Bracket, Tank Retaining,	29	61303	Screw, #8 x 3/8 black trilobe
8	62917	Control Brkt Assy PIC6	30	61304	Screw,6-32 x 1/2 PPH,SS
9	62831	Splash Panel,	31	60080	Clamp,5/8"Nylon **SC**
10	62802	Blower Assembly 120V	32	62914	Decal, Switch Button PIC5/6
11	62866	Tray, Drain PIC6	33	61440	CAP, #8 SCREW SOFT
12	62874	Lid Assy PIC6	34	62981	Decal,Caution,Splash
13	62922	Drain Grid PIC6	35	61452	Decal, Cleaning Instr 5# HPR
14	71256	Leg, 4" Plastic	36	100268	Decal,Caution,Behind Drip Tray
15	71160	Clip,Syphon Hose w/Blk Adhsv	37	61372	Hopper Asy PIC Single Pinw
16	62835	Tee, 1.25"	38	61834	Decal, FLVR Strip
17	62845-2	TUBING, 1-1/4X14 LONG FLEX	39	61146	Instr, Manual PIC Domestic
18	62845-1	TUBING, 1-1/4X14 LONG FLEX	40	00800	SERIAL PLATE
19	62845-3	TUBING, 1-1/4X14 LONG FLEX	41	61463	Tag, Instalation
20	62992	Mural, Panel PIC5/6			
21	62836	Tubing Asy,Drain,PIC5			
22	61237	Fitting,Assy,1/4 fl X 3/4 Hs, Brs			

PIC 1 120V and 120/240V "Q" Model Wiring

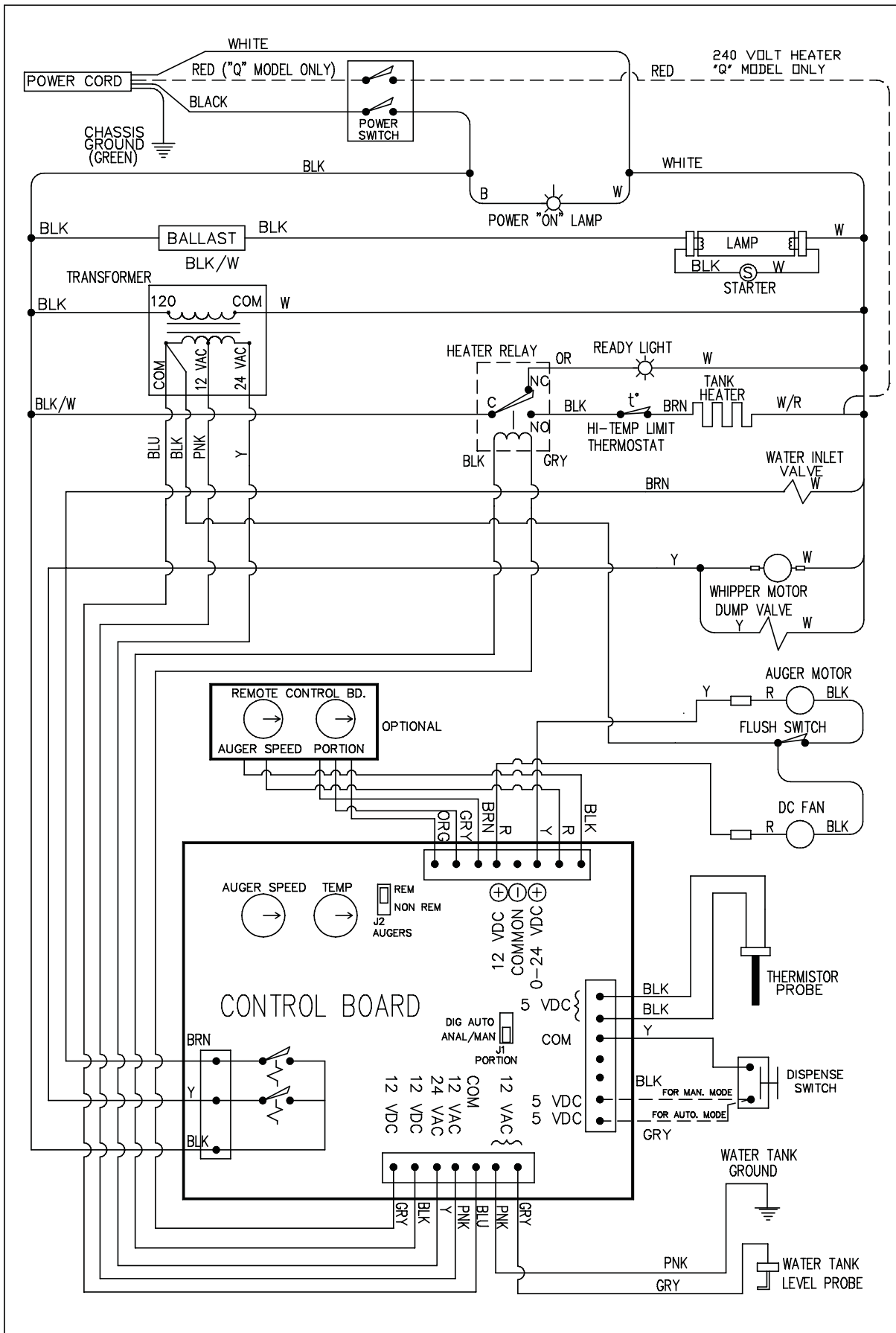

PIC 1 230V "E" Model Wiring

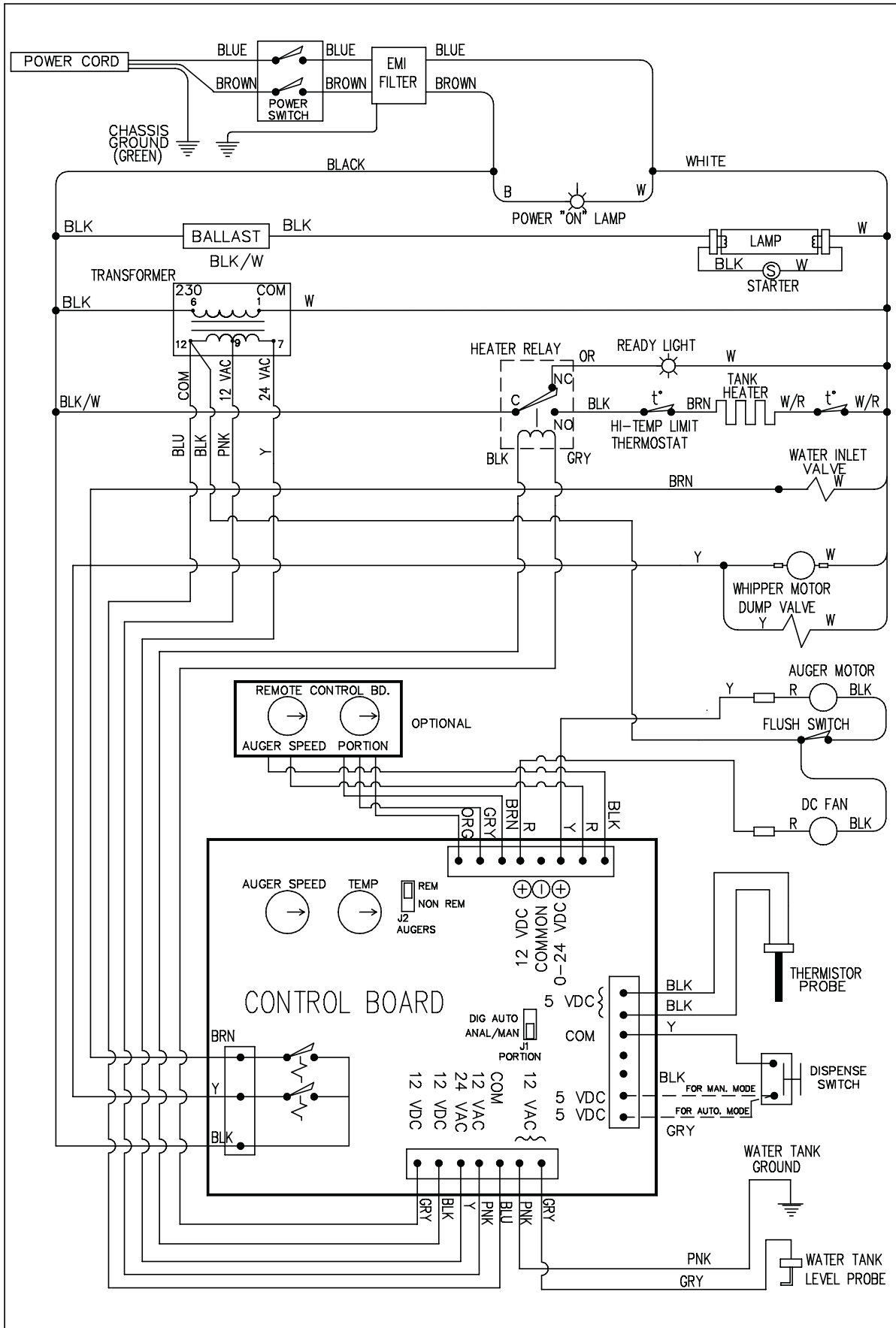

PIC1KE or PIC1KAE, 230V "E" Model Wiring

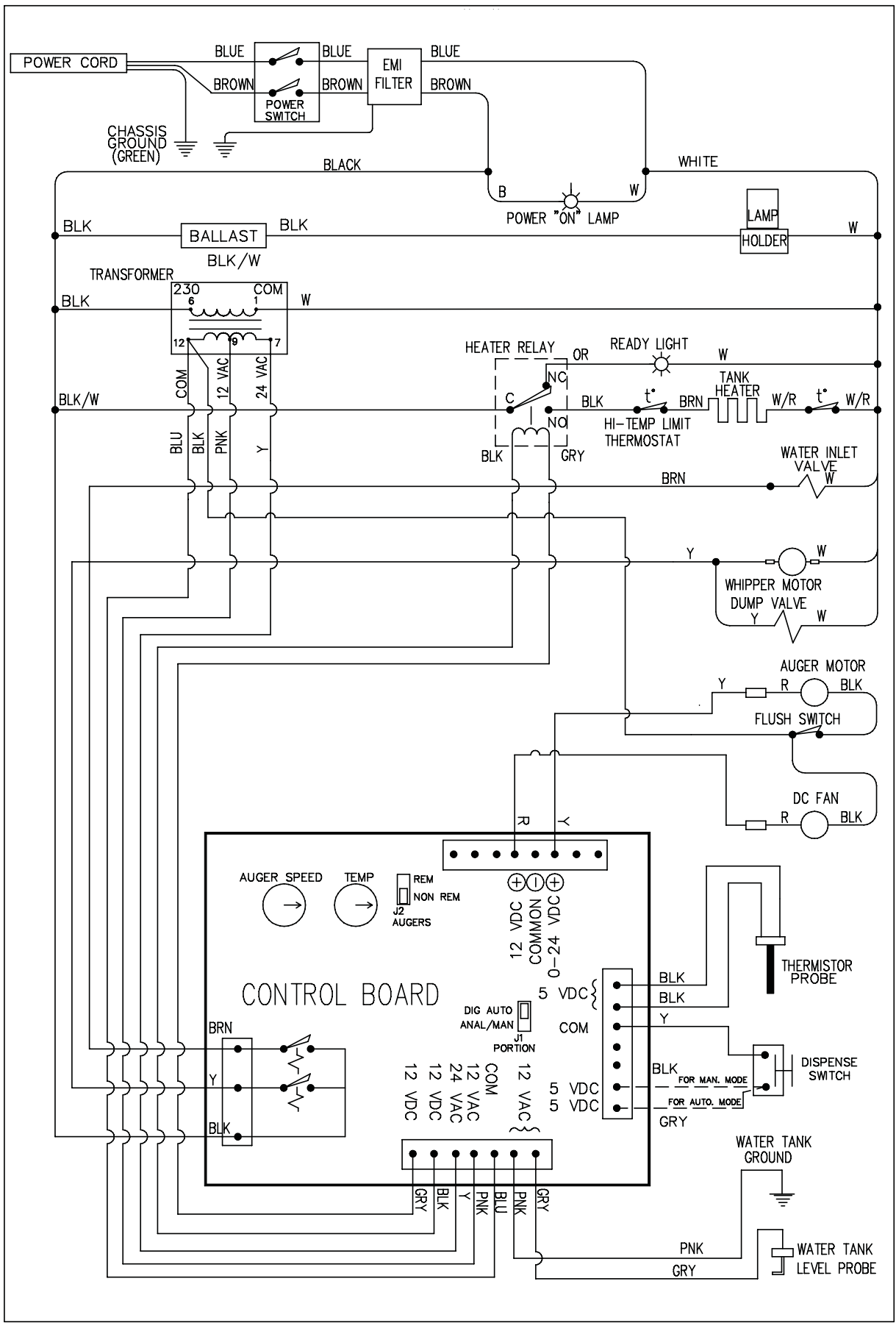

PIC1K or PIC1KA 120 & 120/240 "Q" Model Wiring

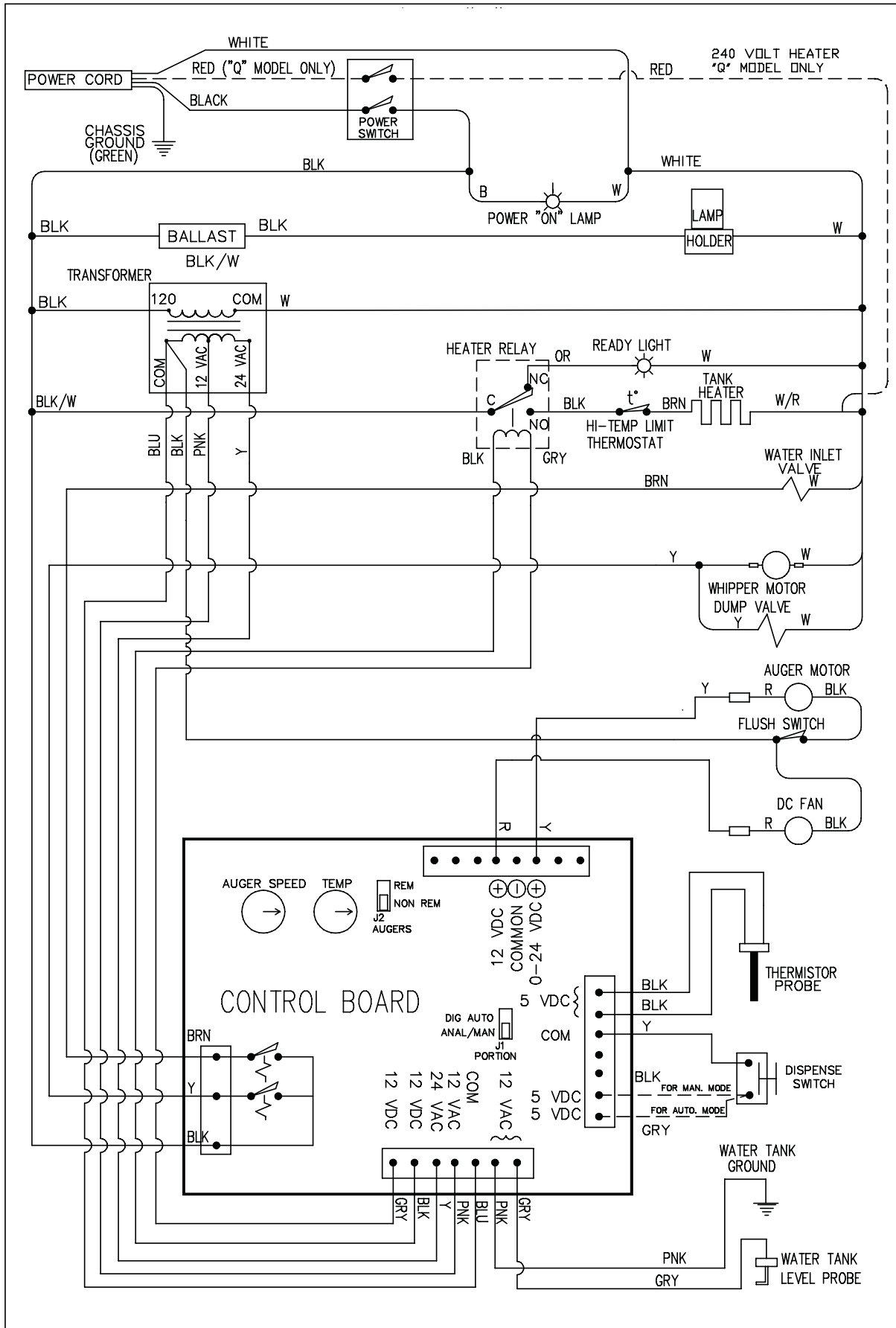

PIC1KAEW or PIC1KEW Wiring

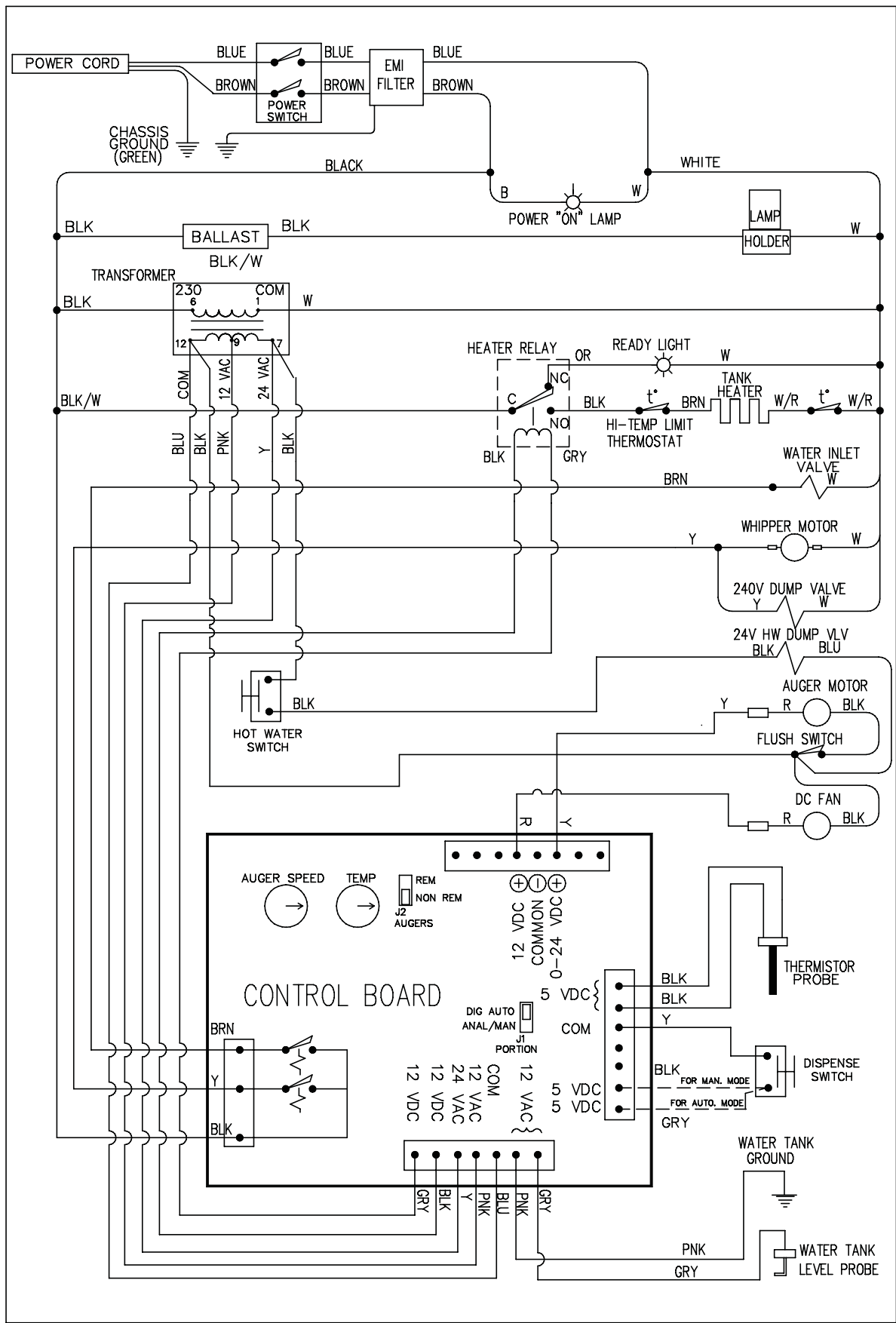

CAP1AE or CAP1E 230V "E" Model Wiring

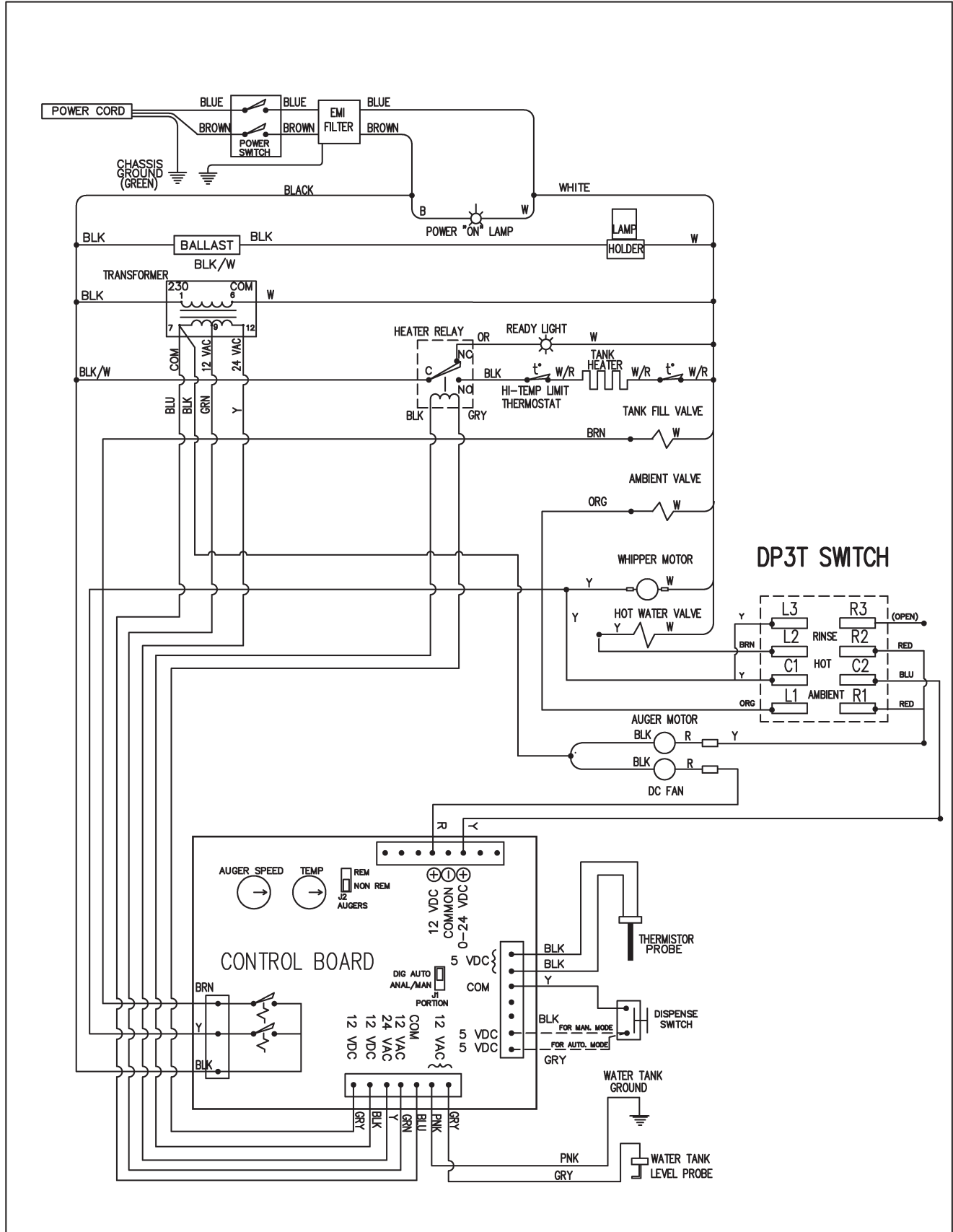

PIC 2/3 120 & 120/240V "Q" Model Wiring

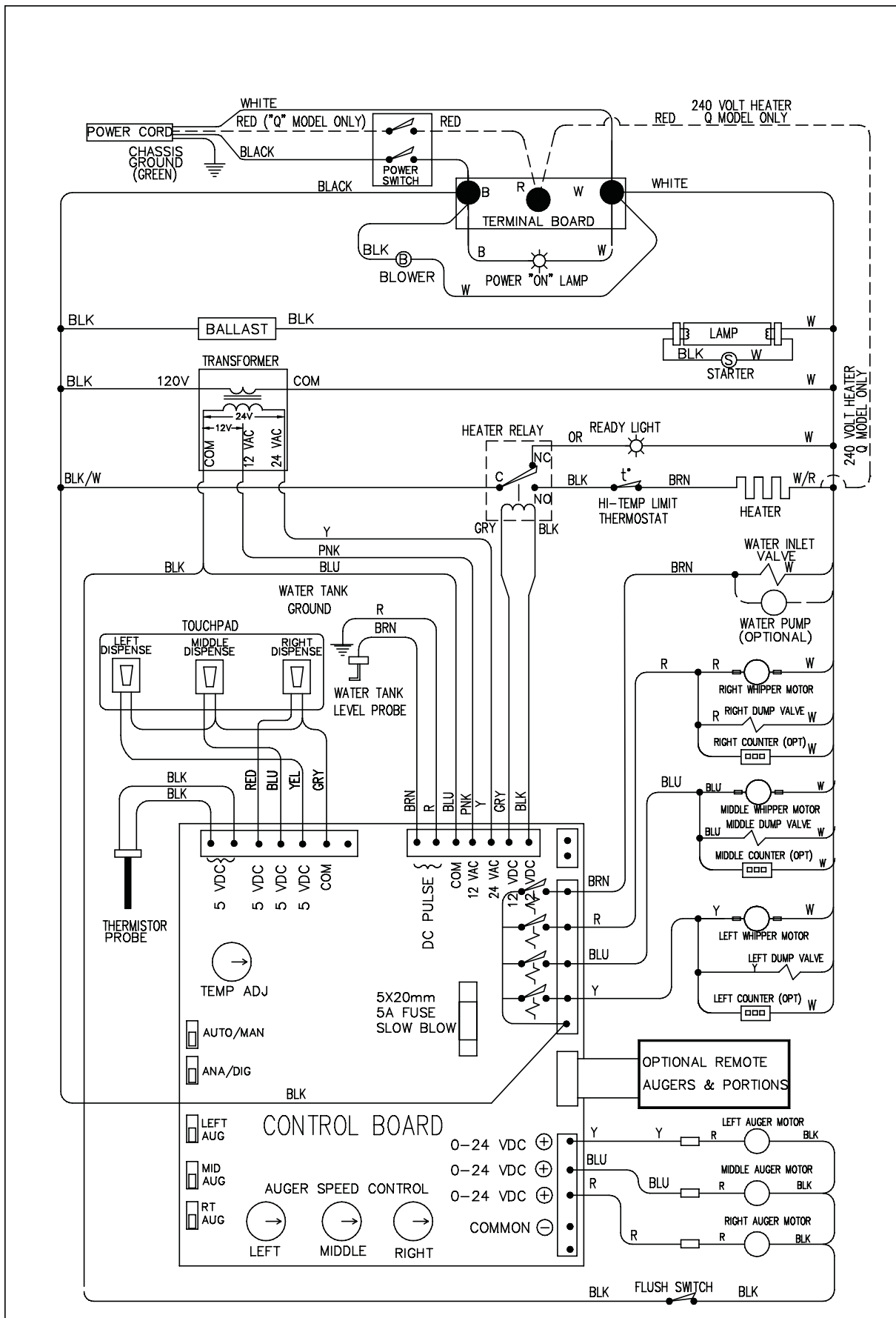

PIC 23A, PIC33A 120 & 120/240V "Q" Model with 3-Portion Touch Pads

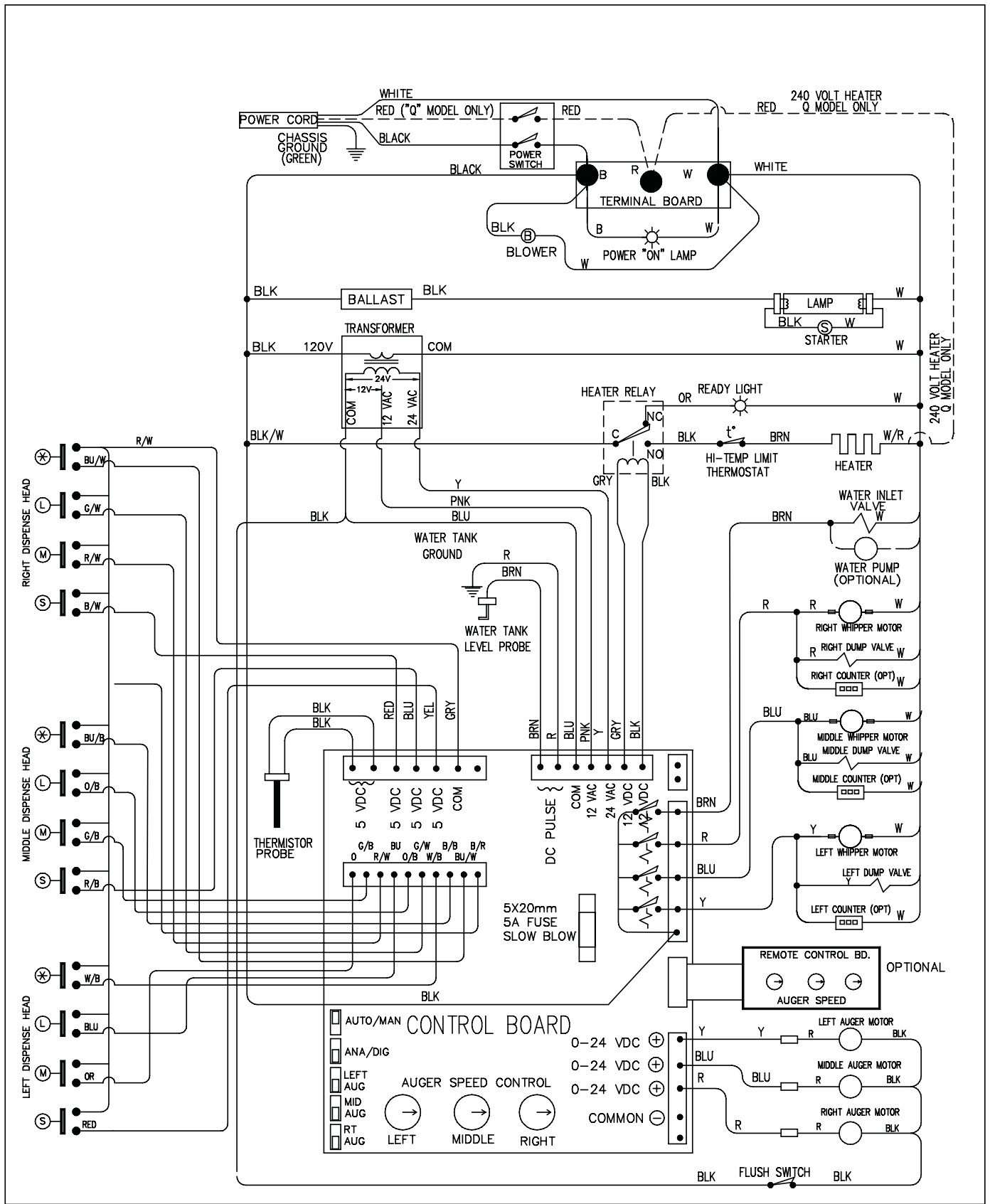

PIC33AE 230V "CE" Model Wiring with 3-Portion Touch Pads

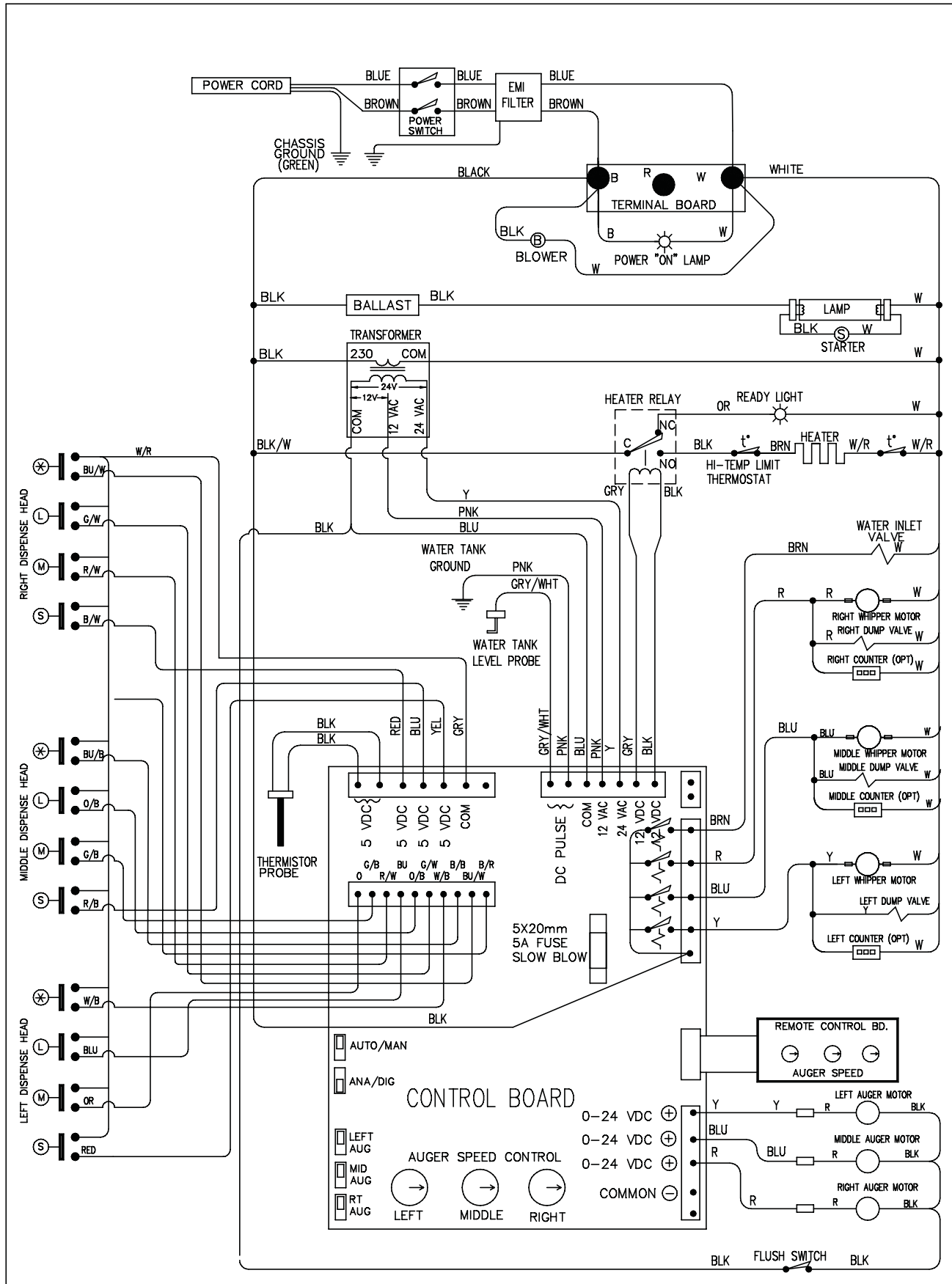

PIC 2/3 100 & 200V "J" Model Wiring

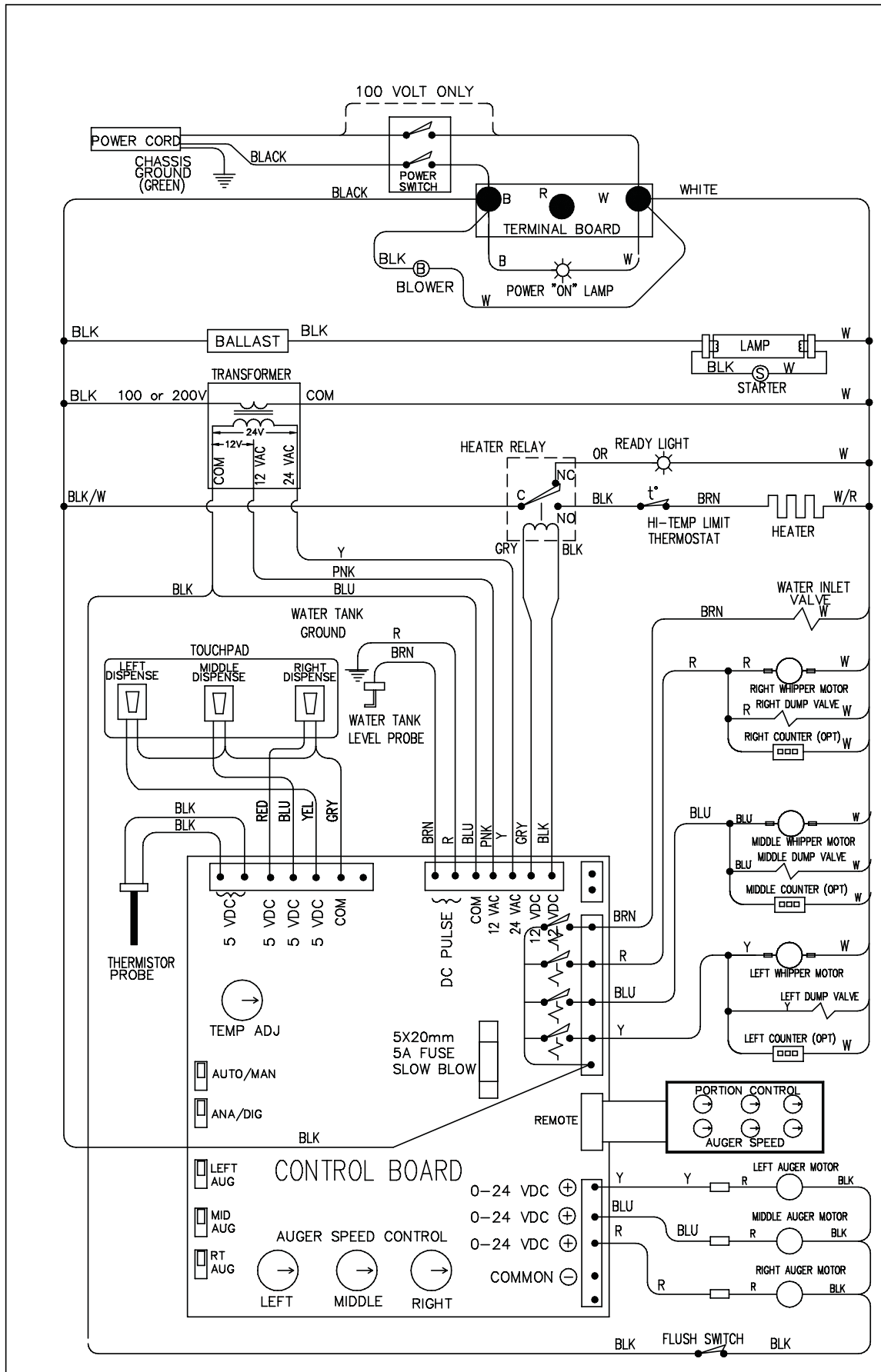

PIC23A, PIC33A 100 & 200V "J" Model Wiring with 3-Portion Touch Pads

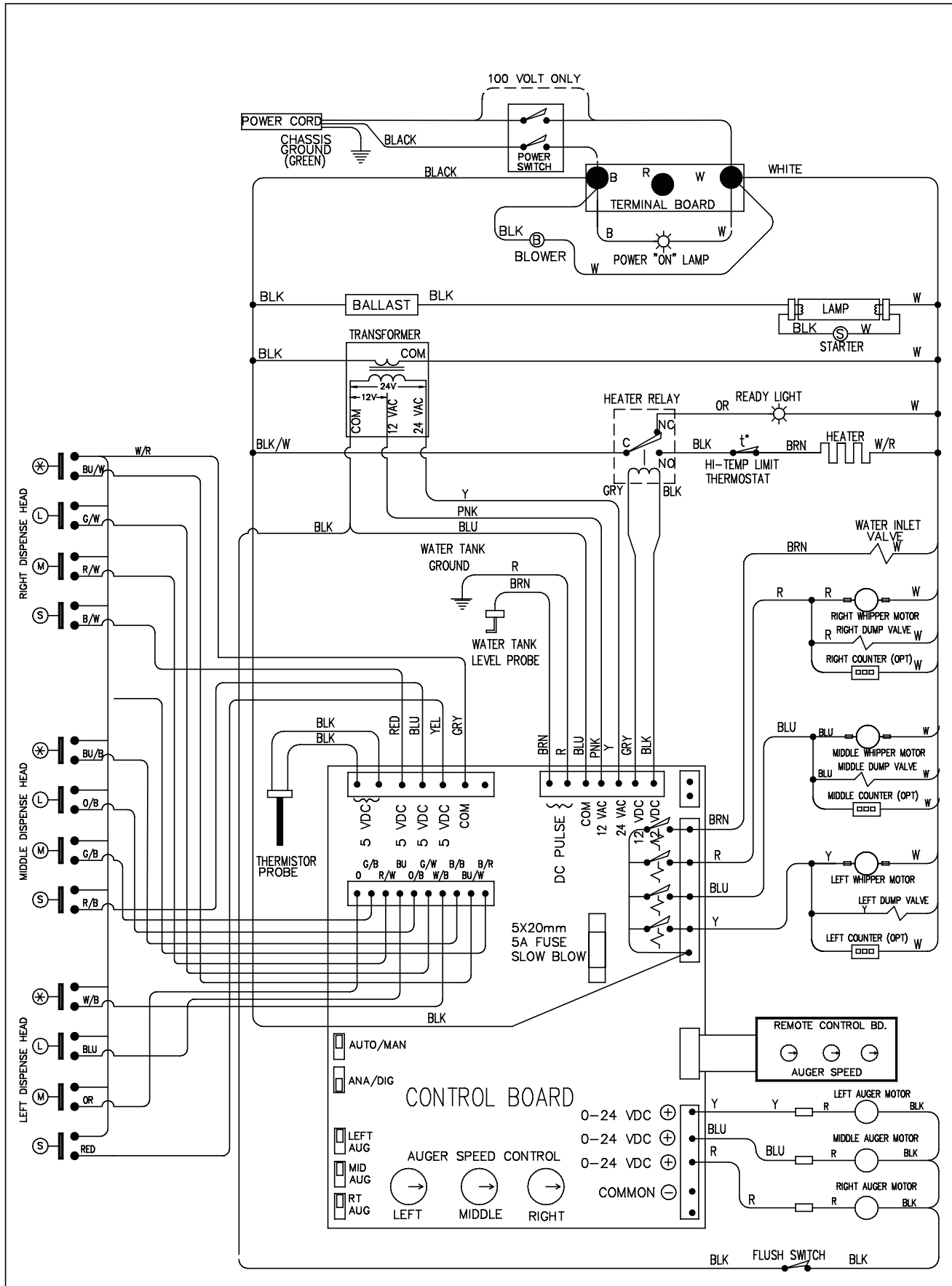

PIC3E or PIC3AE, 230/240VAC 50/60Hz Model Wiring with Remote Portion Control

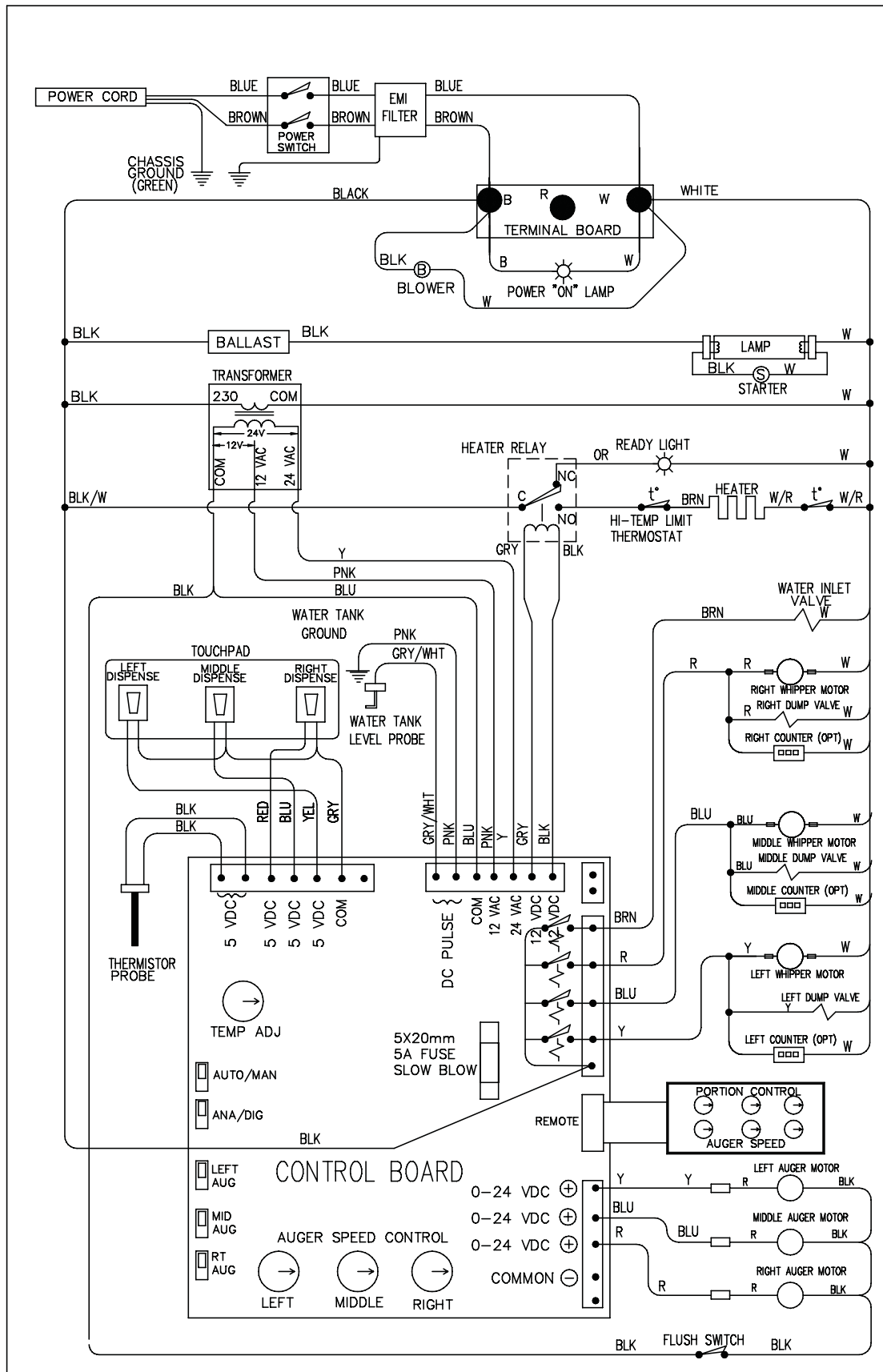

PIC 4 Wiring

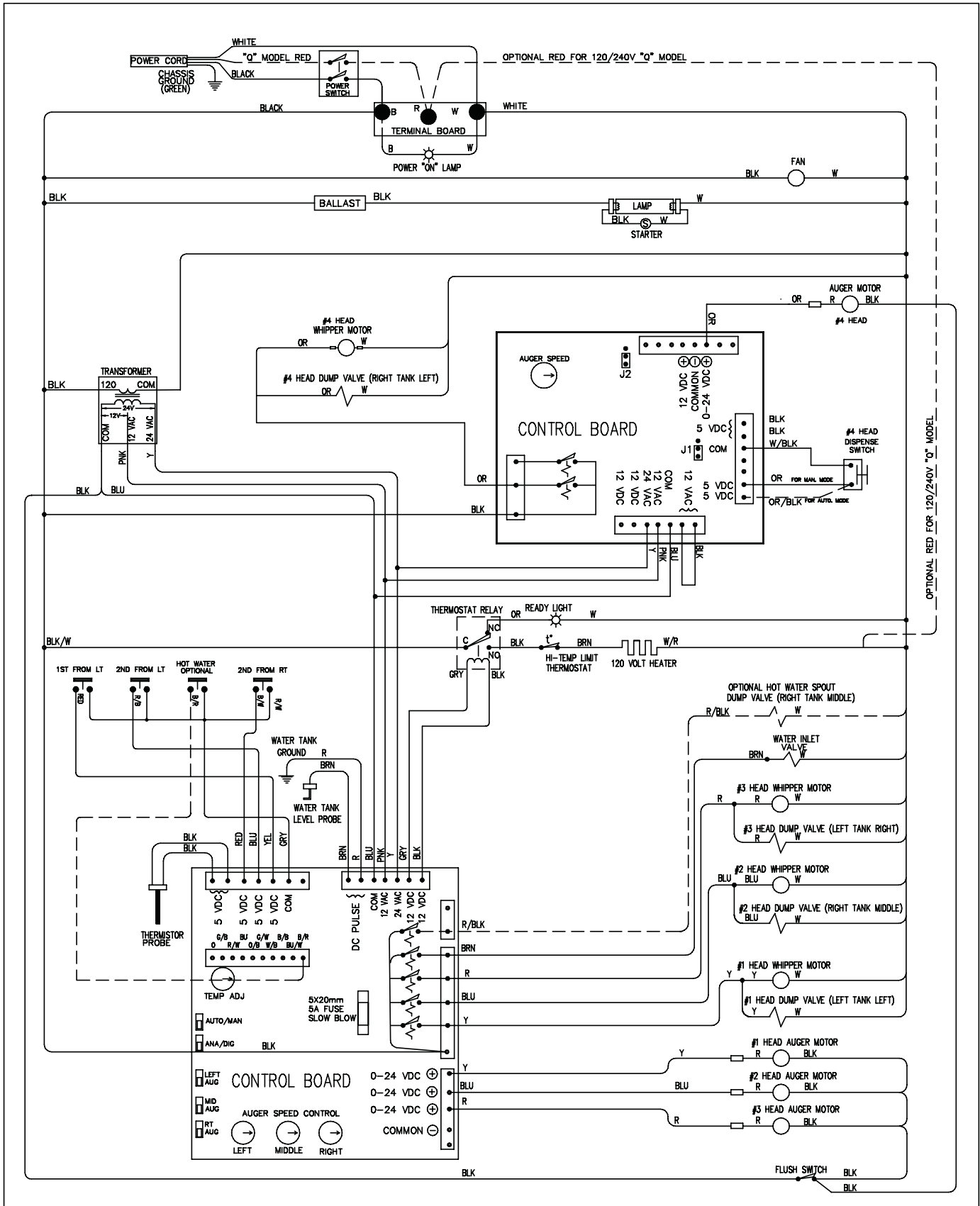

PIC43A 120V & PIC43AQ 120/240V Wiring

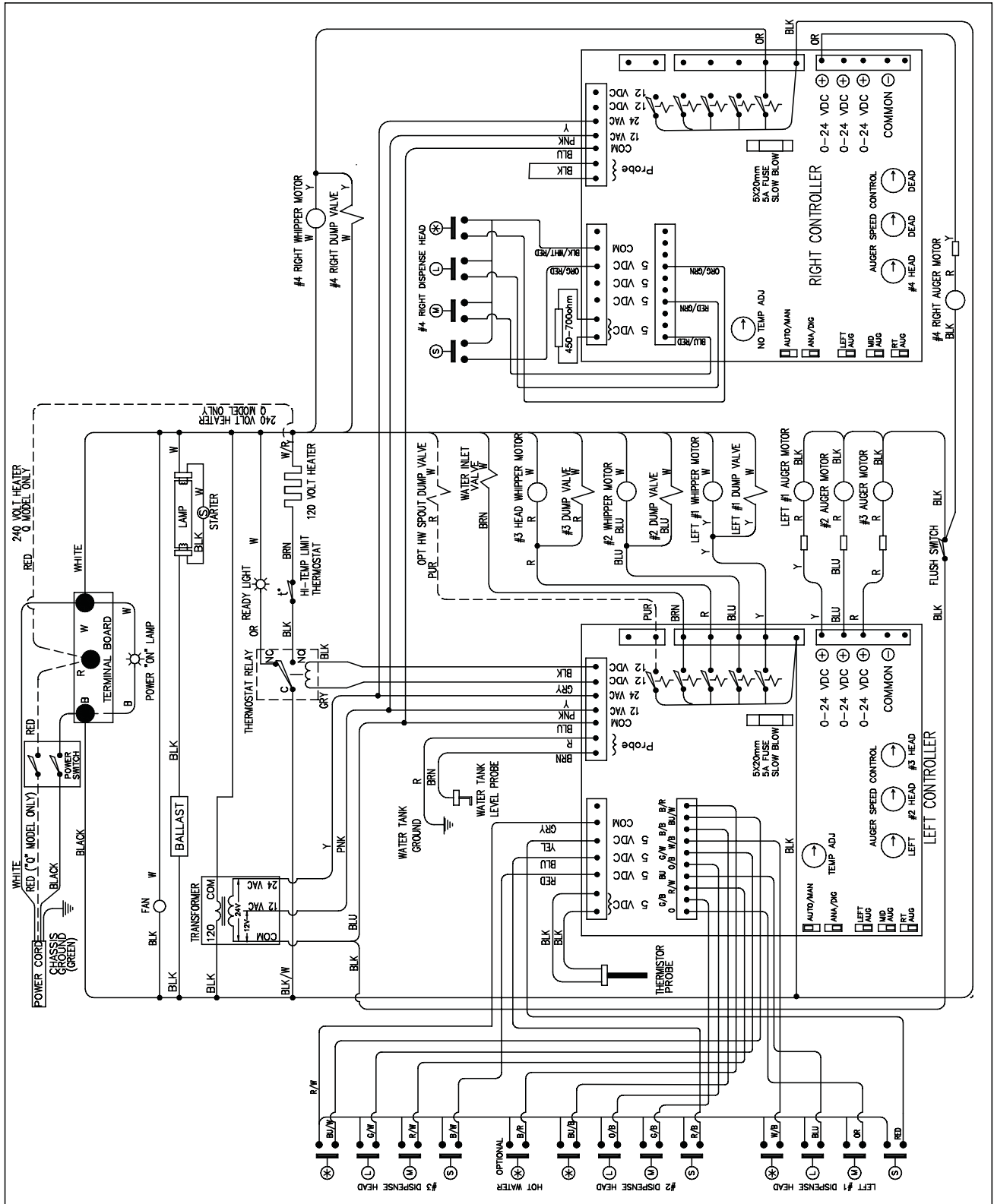

PIC43AZ and PIC43AWZ Model Wiring with 3-Port Touchpad

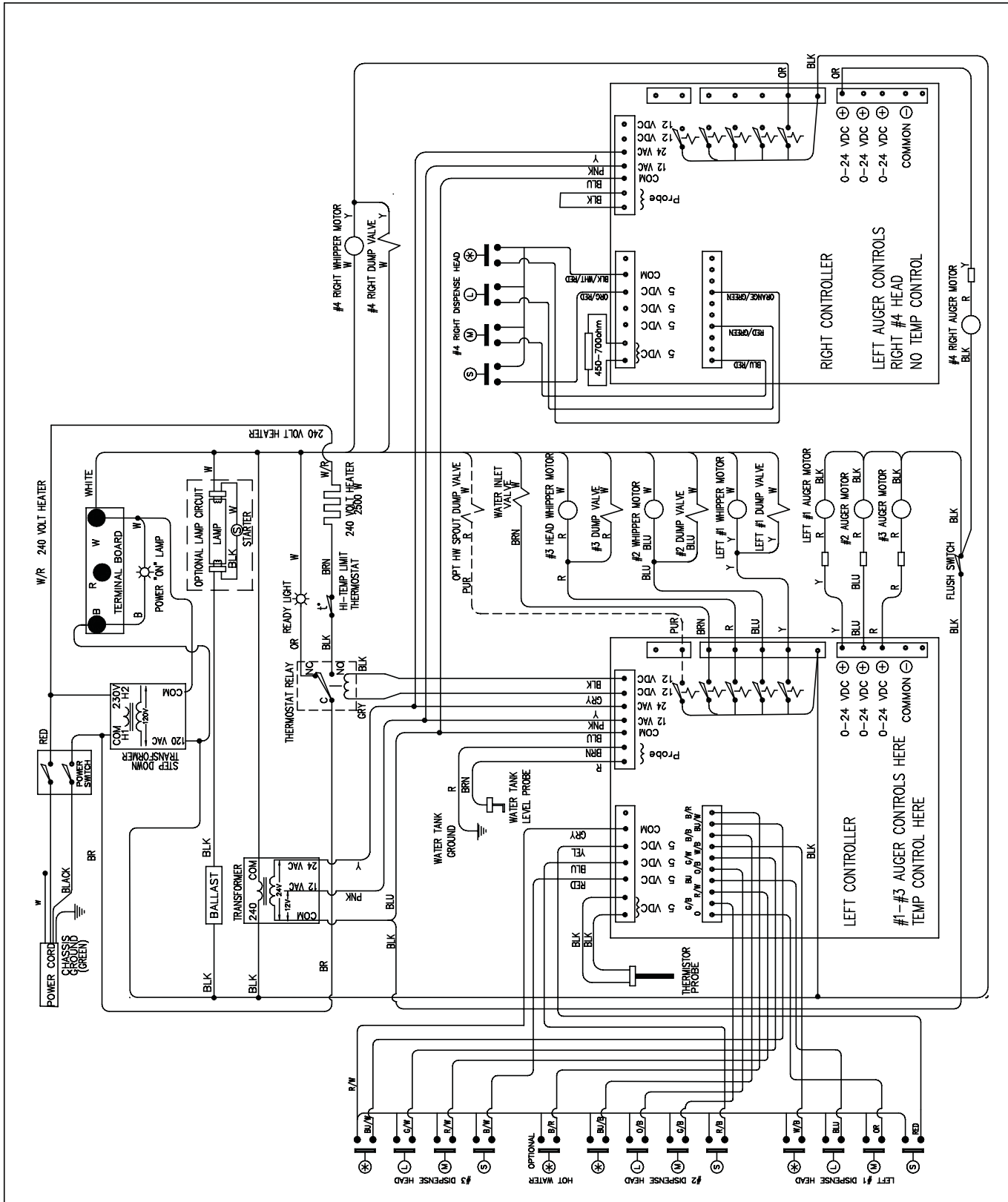

PIC4Z, PIC4AZ, PIC4WZ, PIC4AWZ 240V Model Wiring

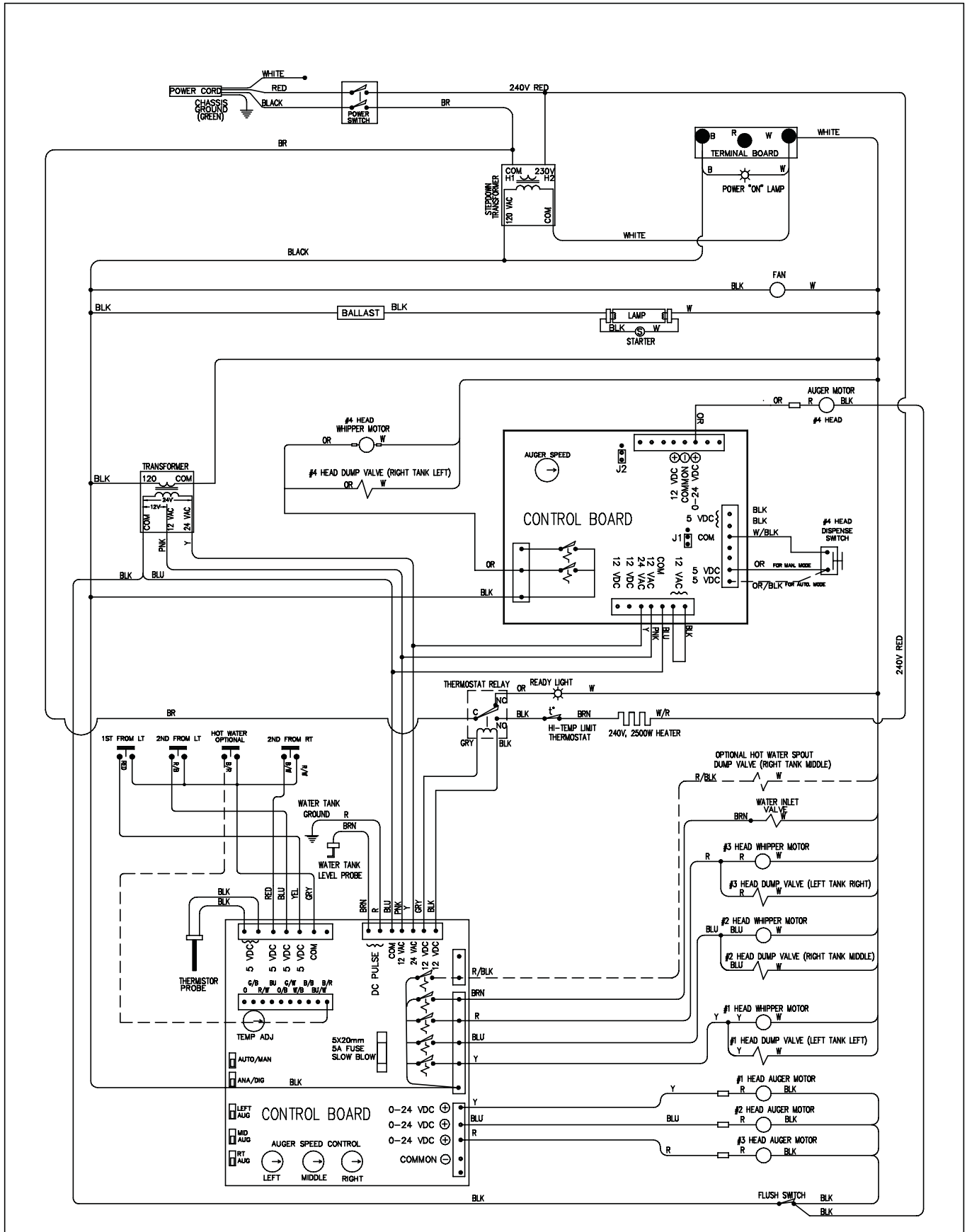

PIC 5/6 Wiring

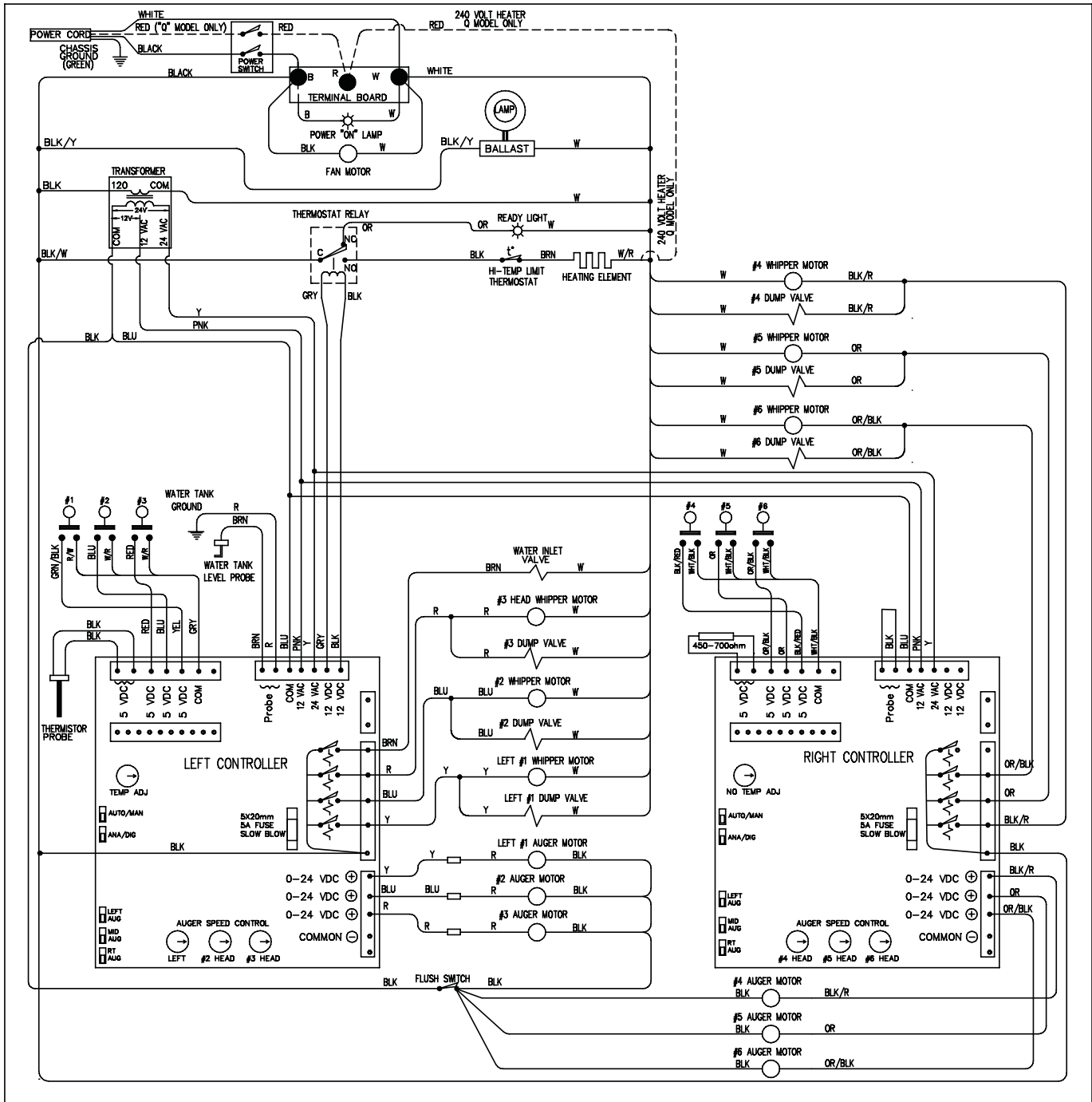



GRINDMASTER™

C O R P O R A T I O N

Grindmaster® Coffee Grinders and Brewers • PrecisionBrew™ Brewing Systems • Espresso® Espresso Machines
Crathco® Hot Beverage Dispensers • Crathco® Cold and Frozen Beverage Dispensers • AMW Coffee and Tea Systems
Tel (502) 425-4776 • Fax (502) 425-4664 • 1-800-695-4500 (USA & Canada only)
P.O. Box 35020 • Louisville, KY 40232 • USA