BUNN®

JDF-2S

Silver Series®



ILLUSTRATED PARTS CATALOG

Designs, materials, weights, specifications, and dimensions for equipment or replacement parts are subject to change without notice.

BUNN-O-MATIC CORPORATION

POST OFFICE BOX 3227

SPRINGFIELD, ILLINOIS 62708-3227

PHONE: (217) 529-6601 FAX: (217) 529-6644



BUNN-O-MATIC COMMERCIAL PRODUCT WARRANTY

Bunn-O-Matic Corp. ("BUNN") warrants equipment manufactured by it as follows:

- 1) All equipment other than as specified below: 2 years parts and 1 year labor.
- 2) Electronic circuit and/or control boards: parts and labor for 3 years.
- 3) Compressors on refrigeration equipment: 5 years parts and 1 year labor.
- 4) Grinding burrs on coffee grinding equipment to grind coffee to meet original factory screen sieve analysis: parts and labor for 3 years or 30,000 pounds of coffee, whichever comes first.

These warranty periods run from the date of installation BUNN warrants that the equipment manufactured by it will be commercially free of defects in material and workmanship existing at the time of manufacture and appearing within the applicable warranty period. This warranty does not apply to any equipment, component or part that was not manufactured by BUNN or that, in BUNN's judgment, has been affected by misuse, neglect, alteration, improper installation or operation, improper maintenance or repair, damage or casualty. This warranty is conditioned on the Buyer 1) giving BUNN prompt notice of any claim to be made under this warranty by telephone at (217) 529-6601 or by writing to Post Office Box 3227, Springfield, Illinois 62708-3227; 2) if requested by BUNN, shipping the defective equipment prepaid to an authorized BUNN service location; and 3) receiving prior authorization from BUNN that the defective equipment is under warranty.

THE FOREGOING WARRANTY IS EXCLUSIVE AND IS IN LIEU OF ANY OTHER WARRANTY, WRITTEN OR ORAL, EXPRESS OR IMPLIED, INCLUDING, BUT NOT LIMITED TO, ANY IMPLIED WARRANTY OF EITHER MERCHANTABILITY OR FITNESS FOR A PARTICULAR PURPOSE. The agents, dealers or employees of BUNN are not authorized to make modifications to this warranty or to make additional warranties that are binding on BUNN. Accordingly, statements by such individuals, whether oral or written, do not constitute warranties and should not be relied upon.

If BUNN determines in its sole discretion that the equipment does not conform to the warranty, BUNN, at its exclusive option while the equipment is under warranty, shall either 1) provide at no charge replacement parts and/or labor (during the applicable parts and labor warranty periods specified above) to repair the defective components, provided that this repair is done by a BUNN Authorized Service Representative; or 2) shall replace the equipment or refund the purchase price for the equipment.

THE BUYER'S REMEDY AGAINST BUNN FOR THE BREACH OF ANY OBLIGATION ARISING OUT OF THE SALE OF THIS EQUIPMENT, WHETHER DERIVED FROM WARRANTY OR OTHERWISE, SHALL BE LIMITED, AT BUNN'S SOLE OPTION AS SPECIFIED HEREIN, TO REPAIR, REPLACEMENT OR REFUND.

In no event shall BUNN be liable for any other damage or loss, including, but not limited to, lost profits, lost sales, loss of use of equipment, claims of Buyer's customers, cost of capital, cost of down time, cost of substitute equipment, facilities or services, or any other special, incidental or consequential damages.

AutoPOD, AXIOM, BrewLOGIC, BrewMETER, Brew Better Not Bitter, BrewWISE, BrewWIZARD, BUNN Espresso, BUNN Family Gourmet, BUNN Gourmet, BUNN Pour-O-Matic, BUNN, BUNN with the stylized red line, BUNNlink, Bunn-OMatic, Bunn-O-Matic, BUNNserve, BUNNSERVE with the stylized wrench design, Cool Froth, DBC, Dr. Brew stylized Dr. design, Dual, Easy Pour, EasyClear, EasyGuard, FlavorGuard, Gourmet Ice, Gourmet Juice, High Intensity, iMIX, Infusion Series, Intellisteam, My Café, PowerLogic, Quality Beverage Equipment Worldwide, Safety-Fresh, savemycoffee.com, Scale-Pro, Silver Series, Single, Smart Funnel, Smart Hopper, SmartWAVE, Soft Heat, SplashGuard, The Mark of Quality in Beverage Equipment Worldwide, ThermoFresh, 392, Beverage Bar Creator, Beverage Profit Calculator, BUNNSource, Coffee At Its Best, Digital Brewer Control, Nothing Brews Like a BUNN, Pouring Profits, Respect Earth, Respect Earth with the stylized leaf and coffee cherry design, Signature Series, Tea At Its Best, The Horizontal Red Line, Titan, Ultra are either trademarks or registered trademarks of Bunn-O-Matic Corporation.

TABLE OF CONTENTS

Main Frame & Covers.....	4
Upper Cabinet & Panels.....	6
Refrigeration Components.....	8
Compressor Components.....	10
Fan Assembly	12
Water Tank Assy.....	14
Circulation Pump & Lines.....	18
Product Coil & Lines	20
Dispense Platform Assy	22
Dispense Valve Assy.....	24
Plain Water Manifold	26
Door Assy - Unlited	28
Door Assy - Lited w/Mechanical Switches.....	30
Door Assy - Lited w/Membrane Switches.....	32
Electrical Components.....	34
Refillable Container Assy.....	36
Numerical Index	38

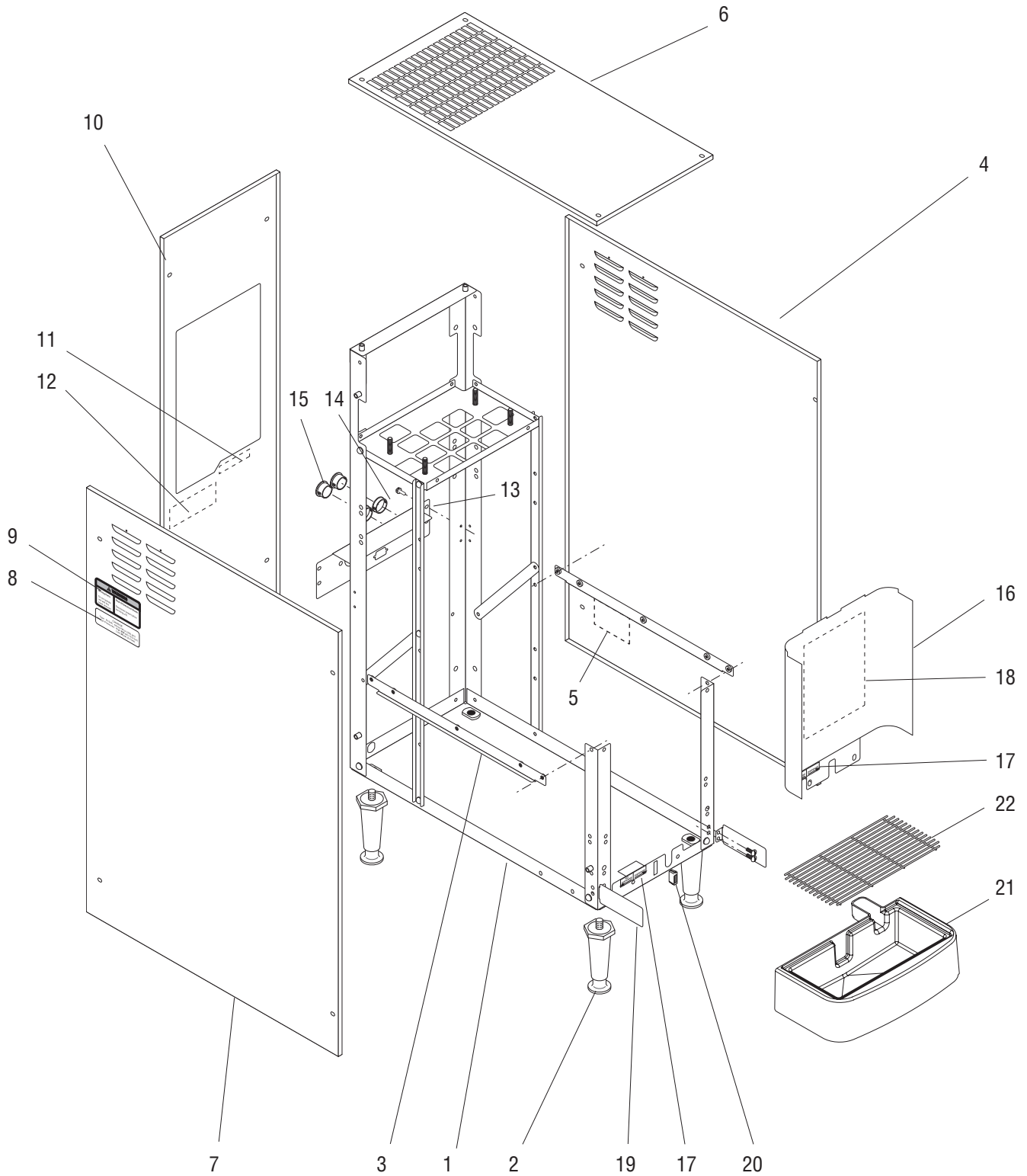

MAIN FRAME & COVERS

ITEM	PART NO.	QTY.	DESCRIPTION
1	38606.0000*	1	Base Frame Assy (Also order item 17)
	38606.0001*	1	Base Frame Assy (Also order item 17)(Models with Dual Dispense option)
2	26528.0000	4	Leg
	03996.0000	4	Pad, Non-skid
3	38654.0000*	1	Bracket, Side
	02308.0000	4	Screw, Pan Head #8-32 x .38"
4	38717.1001	1	Panel w/Decals, Right (Includes item 5)
	39491.1002	1	Panel w/Decals, Right (Includes item 5)(Models with Dual Dispense option)
	02331.0001	4	Screw, Truss Head, Blk #10-32 x .38"
	01512.0000	1	Lockwasher, Ext.-tooth #10
5	00986.7000	1	Decal, Warning - Electrical
6	38719.1001	1	Panel, Top
	02331.0001	4	Screw, Truss Head, Blk #10-32 x .38"
	01512.0000	1	Lockwasher, Ext.-tooth #10
7	38716.1001	1	Panel w/Decals, Left (Includes items 8 & 9)
	39491.1003	1	Panel w/Decals, Left (Includes items 8 & 9)(Models with Dual Dispense option)
	02331.0001	4	Screw, Truss Head, Blk #10-32 x .38"
	01512.0000	1	Lockwasher, Ext.-tooth #10
8	33461.0001	1	Decal, Refrigerant Charge
9	27442.7000	2	Decal, Warning - Moving Parts
10	38718.1003	1	Panel w/Decals, Rear (Includes items 11,12)(Models with Velcro mounted Air Filter)
	42478.1001	1	Panel w/Decals, Rear (Includes items 11, 12)(Models with Frame mounted Air Filter)
	02331.0001	4	Screw, Truss Head, Blk #10-32 x .38"
	01512.0000	1	Lockwasher, Ext.-tooth #10
11	33458.0001	1	Decal, Refrigeration ON - OFF
12	00656.0000	1	Decal, Comply To Plumbing Code
13	38615.0000*	1	Bracket
	38615.0001*	1	Bracket (Models with Dual Dispense option)
	02335.0001	4	Screw, Hex Crimptite #8 x .38"
14	27354.0000	2	Bushing
15	00668.0000	2	Plug
16	38661.0000	1	Panel, Splash (Also order items 17 & 18)
	02308.0000	2	Screw, Pan Head #8-32 x .38"
17	38950.0000	2	Decal, Dispense/No Dispense
18	38951.0000	1	Schematic, Electrical
19	38617.0000	2	Bracket
	02308.0000	4	Screw, Pan Head #8-32 x .38"
20	21436.0000	1	Catch, Magnetic
21	38765.1000	1	Drip Tray Assy (Includes Strike Plate and item 22)
22	26801.0000	1	Grate, Drip Tray

* Indicates the part number listed is for reference only. See DESCRIPTION for possible service replacement.

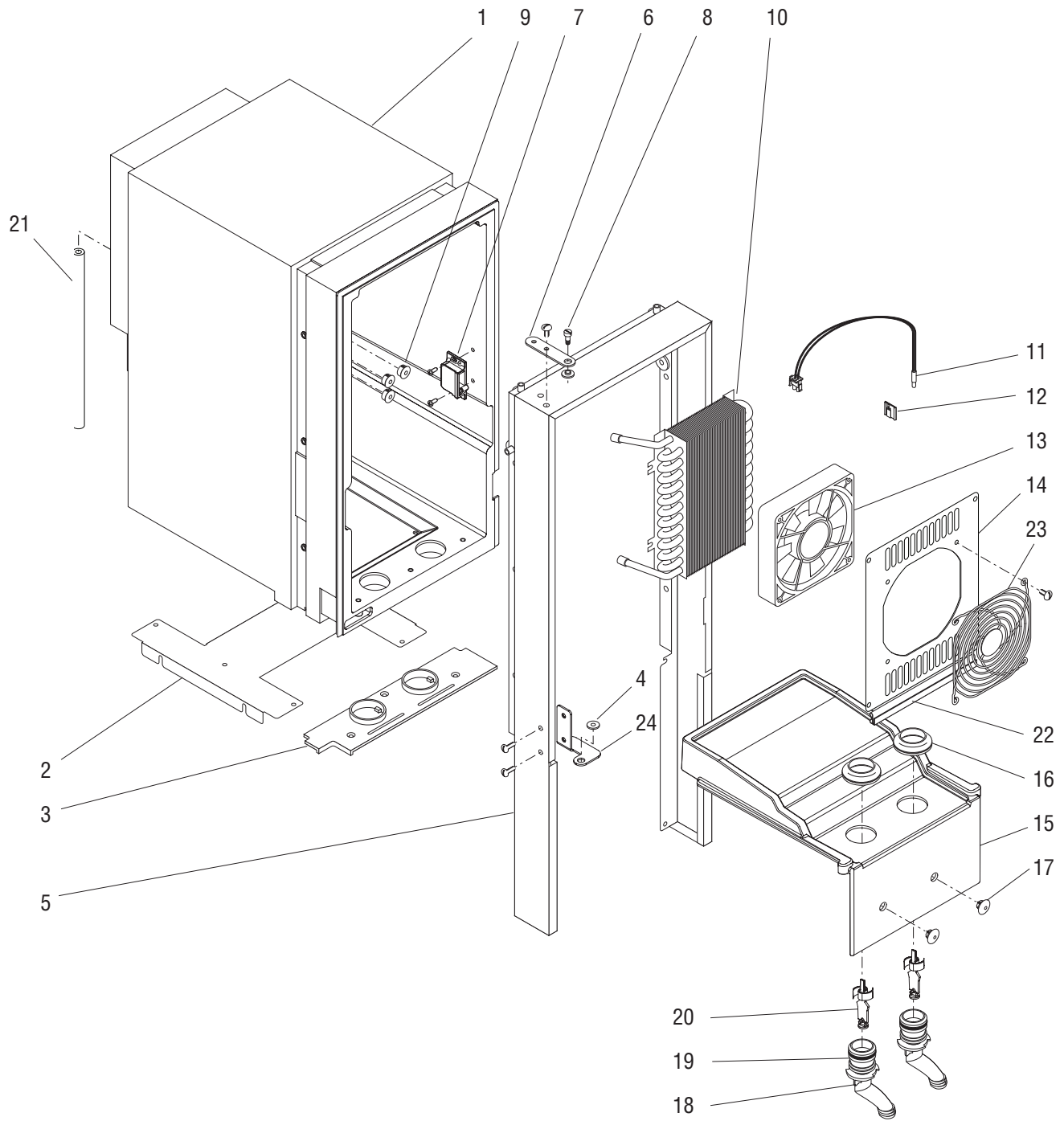

UPPER CABINET & PANELS

ITEM	PART NO.	QTY.	DESCRIPTION
1	38857.0000* 24544.0000	1 6	Cabinet (Not serviced) Screw, Pan Head #8-18
2	34738.0001* 02308.0000	1 4	Plate, Cabinet Mounting Screw, Pan Head #8-32 x .38"
3	34784.0000 01359.0000	1 3	Plate, Bottom Closure Screw, Flat Head #8-32 x .38"
4	34362.0002	1	Bushing, Hinge
5	34790.0001 34790.0002 24544.0000 02308.0000	1 1 6 4	Wrap (Early Models) Wrap (Late Models with bolt on door hinge) Screw, Pan Head #8-1 Screw, Pan Head #8-32 x .38"
6	34785.0001* 02331.0001	1 2	Bracket, Hinge Screw, Truss Head, Blk #10-32 x .38"
7	34666.0001 01388.0000	1 2	Catch, Door Latch Screw, Truss Head #6 x .75"
8	34741.0000	1	Screw, Shoulder
9	00669.0002	3	Plug
10	34419.0001 24544.0000	1 4	Coil, Water Screw, Pan Head #8-18
11	27246.0000	1	Sensor Assy, Temperature
12	33669.0000	1	Clip, Adhesive Back
13	33297.0000 38616.0000	1 2	Fan Assy. Screw, Hex Head #10-24
14	34421.0001 24544.0000	1 4	Cover, Fan Screw, Pan Head #8-18
15	34422.0003	1	Shelf, Product
16	32461.0000	2	Gasket, Drip
17	27394.0000	2	Plug
18	35930.0000 40103.1000 40103.1001	2 2 2	Nozzle Nozzle, Quick Stop, White (Optional)(Includes item 19) Nozzle, Quick Stop, Black (Optional)(Includes item 19)
19	32848.0000	2	O-ring (Also order item 25)
20	35108.1000	2	Mixer, Spiral (Also order item 25)
21	11707.0044*	1	Tube, Silicone .25"ID x 9.0" (Order item 26)
22	39086.0000*	1	Seal, Fan Cover (Late Models)
23	34010.0001 38616.0000	1 2	Guard, Fan Screw, Hex Head #10-24
24	41385.0000 02308.0000	1 2	Bracket (Late Models with bolt on door hinge) Screw, Pan Head #8-32 x .38"
25	M2550.0001	-	Lubrifilm 1.0oz (Use when assembling items 19 & 20)
26	11707.1000	-	Tube, Silicone .25"ID x 12.0" (Use as required)
27	40103.1002 40103.1003	- -	Nozzle Kit, Quick Stop, White (Set of 2) Nozzle Kit, Quick Stop, Black (Set of 2)

* Indicates the part number listed is for reference only. See DESCRIPTION for possible service replacement.

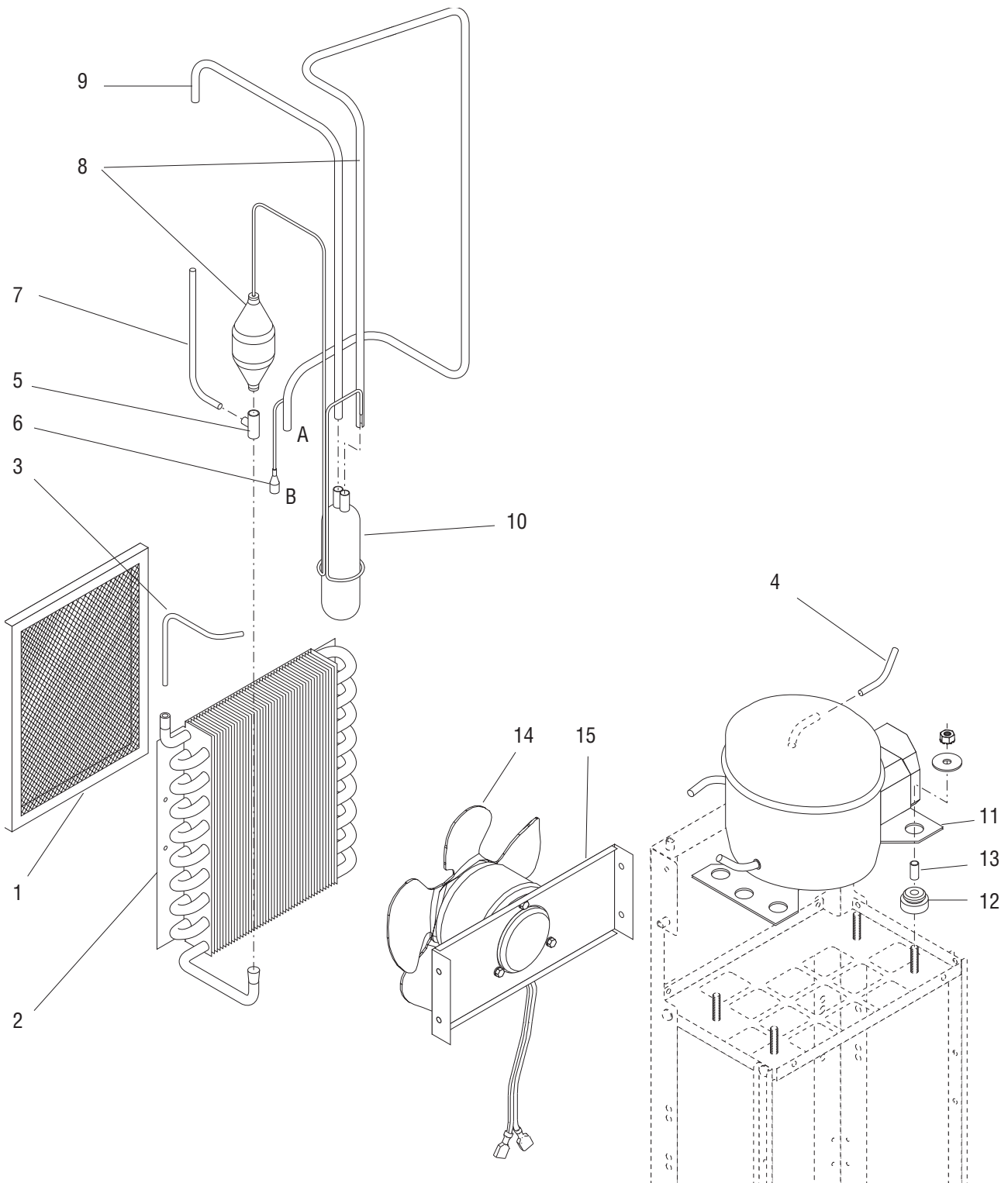

P3615

NOTE: Letters appearing within this illustration correspond to matching connections in other illustrations.

REFRIGERATION COMPONENTS

ITEM	PART NO.	QTY.	DESCRIPTION
1	35164.1001	1	Air Filter
2	29951.0002	1	Condenser
	02335.0001	4	Screw, Crimptite #8 x .38"
3	38921.0001	1	Tube (Requires brazing to install)(120V)
	39227.0001	1	Tube (Requires brazing to install)(230V)
4	38934.0001	1	Tube (Requires brazing to install)
5	00396.0002	1	Tee (Requires brazing to install)
6	35178.0000	1	Adapter (Requires brazing to install)
7	38937.0001	1	Tube (Requires brazing to install)
8	35175.1002	1	Filter Dryer Assy (Requires brazing to install)
9	38922.0001	1	Tube (Requires brazing to install)
10	32776.0000	1	Accumulator
11	-----	1	Compressor (See COMPRESSOR COMPONENTS)
	34529.0000*	4	Washer
	00901.0000	4	Nut .25"-20
12	-----	4	Grommet
13	-----	4	Sleeve
			} Order item 16
14	-----	1	Fan Assy (See FAN ASSEMBLY)
	27243.0000	3	Screw #8-36 x .437"
15	34418.0001*	1	Bracket
	02308.0000	4	Screw, Pan Head #8-32 x .38"
16	28567.0000	1	Mounting Kit (Includes four each of items 12 & 13)
17	M2546.1000	-	Tape, Tube Insulating (Use as required)
18	M2336.1000	-	Insulation, Tube 25/50 - 0.25"ID x .19" wall x 6.0 Ft (Use as required)

* Indicates the part number listed is for reference only. See DESCRIPTION for possible service replacement.

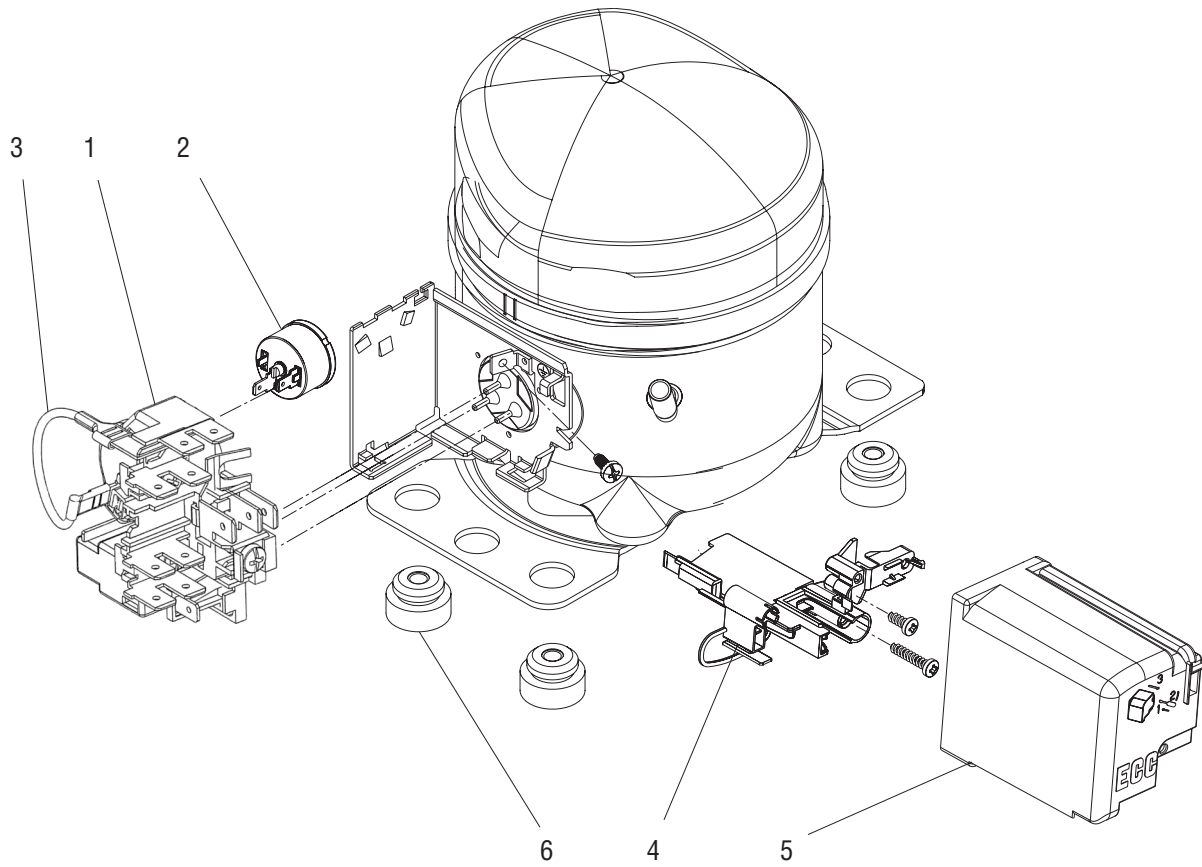

P4040.30

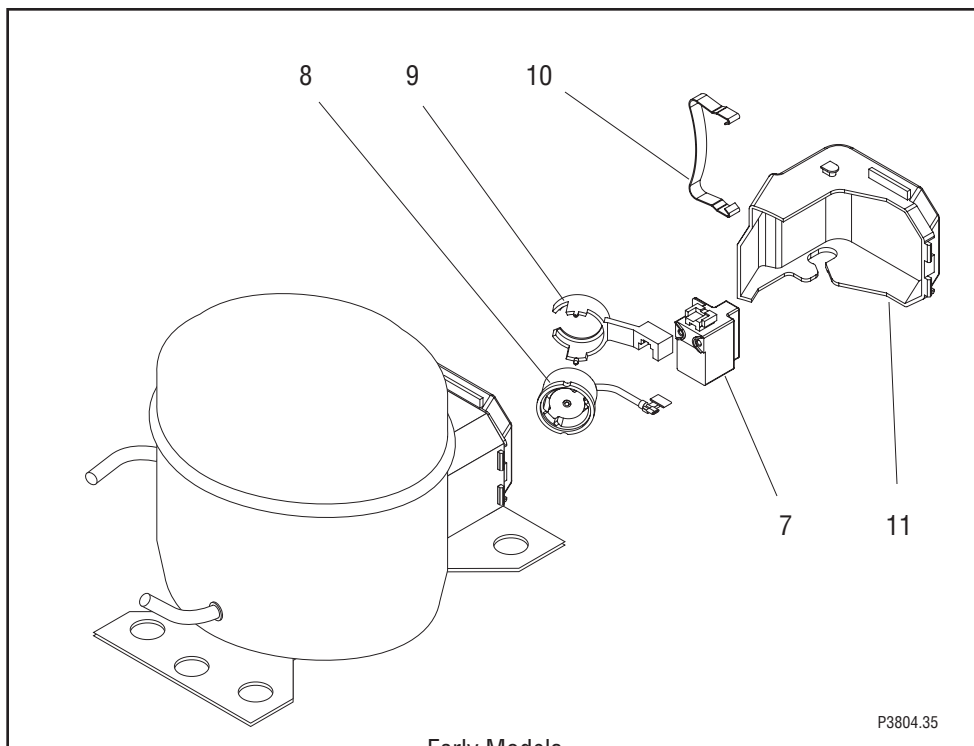

Early Models

P3804.35

COMPRESSOR COMPONENTS

ITEM	PART NO.	QTY.	DESCRIPTION
-	-----	1	Compressor (Early Models. Order new Compressor)
	33522.1002	1	Compressor 120V (Includes items 1 - 6)
	33522.1003	1	Compressor 230V (Includes items 1 - 6)
1	39912.0002	1	Relay, Compressor 120V
	39912.0003	1	Relay, Compressor 230V
2	39908.0002	1	Overload Protector 120V
	39908.0003	1	Overload Protector 230V
3	41398.0000	1	Cable
4	41397.0000	1	Strain Relief
5	39907.0000	1	Cover
6	41396.0000	1	Mounting Kit (Includes 4 Grommets and Sleeves)
7	38897.0000	1	Relay, Compressor 120V
	38897.0001	1	Relay, Compressor 230V
8	38917.0000	1	Overload Protector
9	38916.0000	1	Retainer
10	38918.0000	1	Clip
11	38896.0000	1	Cover

} Early Model Compressors

* Indicates the part number listed is for reference only. See DESCRIPTION for possible service replacement.

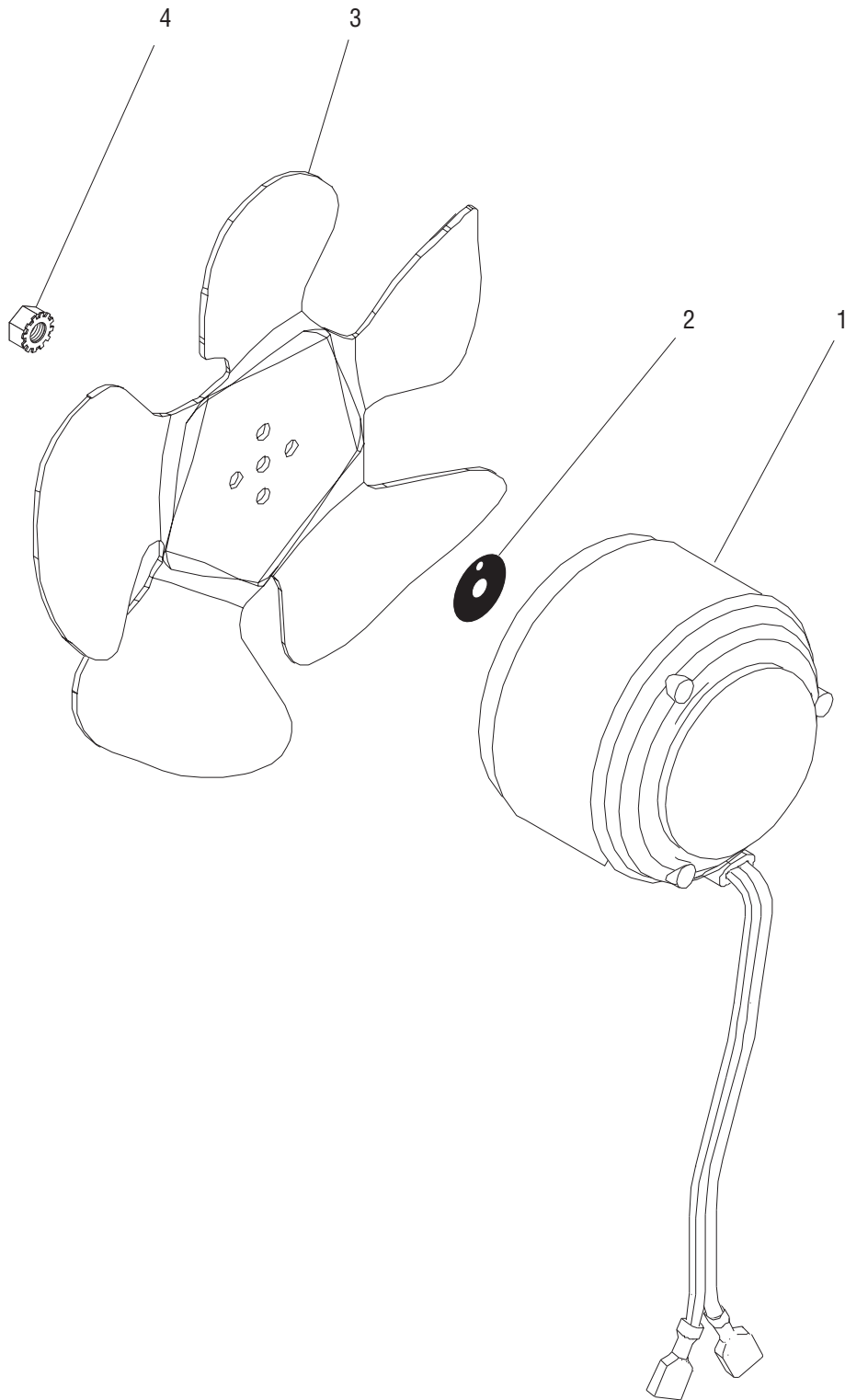

FAN ASSEMBLY

ITEM	PART NO.	QTY.	DESCRIPTION
-	32204.1001	1	Fan Assy 120V (Includes items 1-4)
	32204.1002	1	Fan Assy 230V (Includes items 1-4)
1	33603.0000	1	Motor Assy 120V
	33603.0001	1	Motor Assy 230V
2	33602.0000	1	Blade, Fan
3	27258.0000	1	Silencer
4	23700.0000	1	Nut .25"-20

* Indicates the part number listed is for reference only. See DESCRIPTION for possible service replacement.

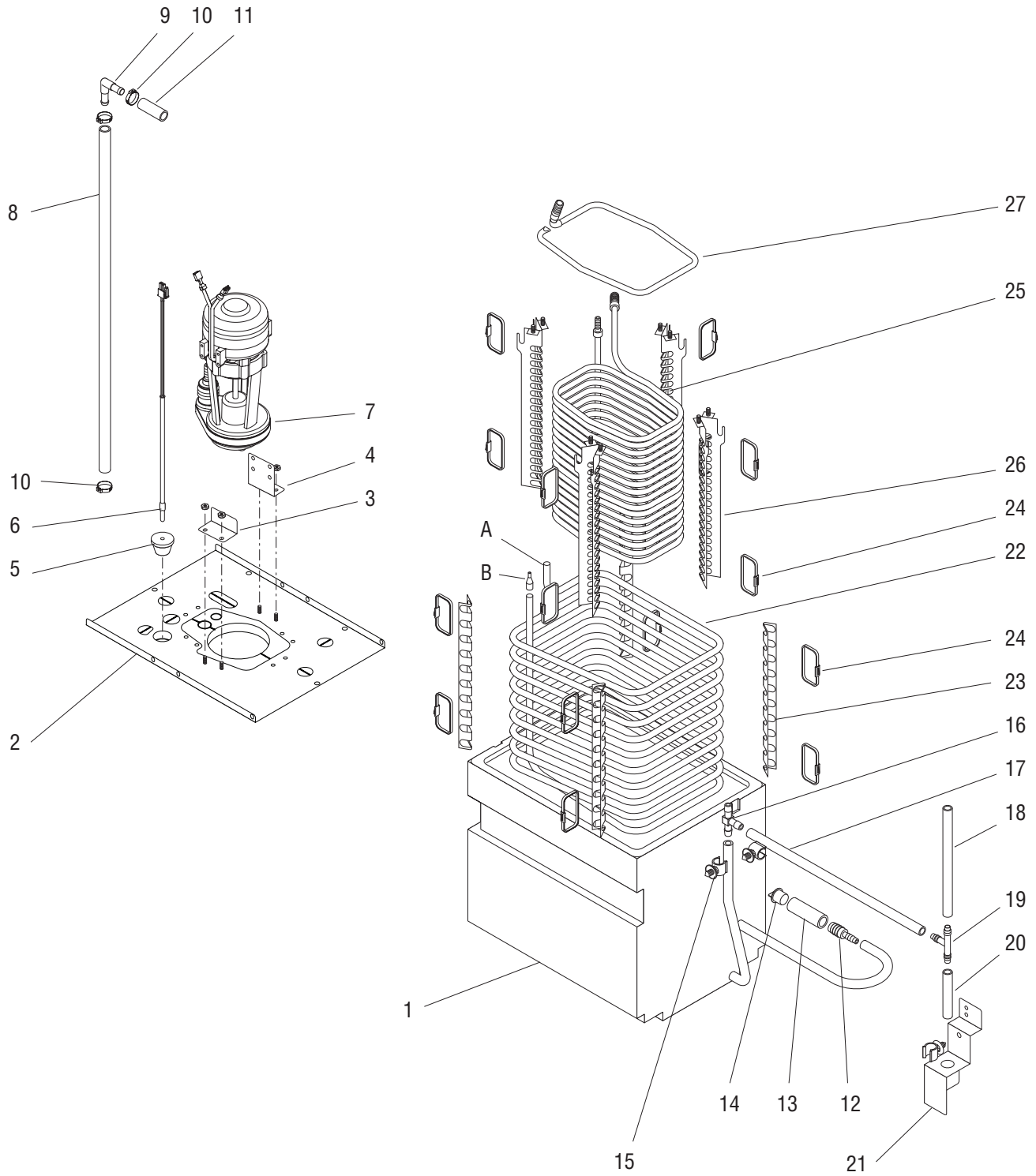

NOTE: Letters appearing within this illustration correspond to matching connections in other illustrations.

P3616

WATER TANK ASSY

ITEM	PART NO.	QTY.	DESCRIPTION
1	35165.0003*	1	Tank Assy
	24544.0000	6	Screw, Pan Head #8-18
2	35272.0002*	1	Lid Assy
	24544.0000	6	Screw, Pan Head #8-18
3	38833.0001	1	Bracket
	00973.0001	2	Nut, Keps #6-32
4	38833.0000	1	Bracket
	00973.0001	2	Nut, Keps #6-32
5	33801.0001	1	Grommet
6	28891.1000	1	Probe, Temperature & Dry Plug
7	38827.0000	1	Pump Assy 120V
	38827.0001	1	Pump Assy 230V
	27243.0000	4	Screw #8-36 x .437"
8	34325.0013*	1	Hose, Flex .38" ID x .625" OD x 20.0" (Order item 30)
9	37850.0000	1	Elbow .38" Barb
10	21275.0003	3	Clamp .57" - .70"
11	34325.0004*	1	Hose, Flex .38" ID x .625" OD x 1.50" (Order item 30)
12	38924.0000	1	Reducer .50 to .25" Barb
13	32591.0014*	1	Hose, Flex .38" ID x .625" OD x 3.0" (Order item 32)
14	38925.0000	1	Plug
15	27410.0000	3	Clip, Tube Mounting
16	33153.0000	1	Tee .25" Barb
17	11707.0016*	1	Tube, Silicone .25" ID x 8.0" (Order item 31)
18	11707.0043*	1	Tube, Silicone .25" ID x 6.25" (Order item 31)
19	38605.0000	1	Tee .25" Barb
20	11707.0009*	1	Tube, Silicone .25" ID x 2.6" (Order item 31)
21	38662.0000*	1	Bracket
	02308.0000	2	Screw, Pan Head #8-32 x .38"
22	33519.0001	1	Evaporator Coil
23	33533.0000*	4	Spacer
24	36329.0002	20	Cable Tie
25	38828.0000*	1	Product Coil
26	34416.0000	4	Spacer

(Continued)

* Indicates the part number listed is for reference only. See DESCRIPTION for possible service replacement.

(Continued)

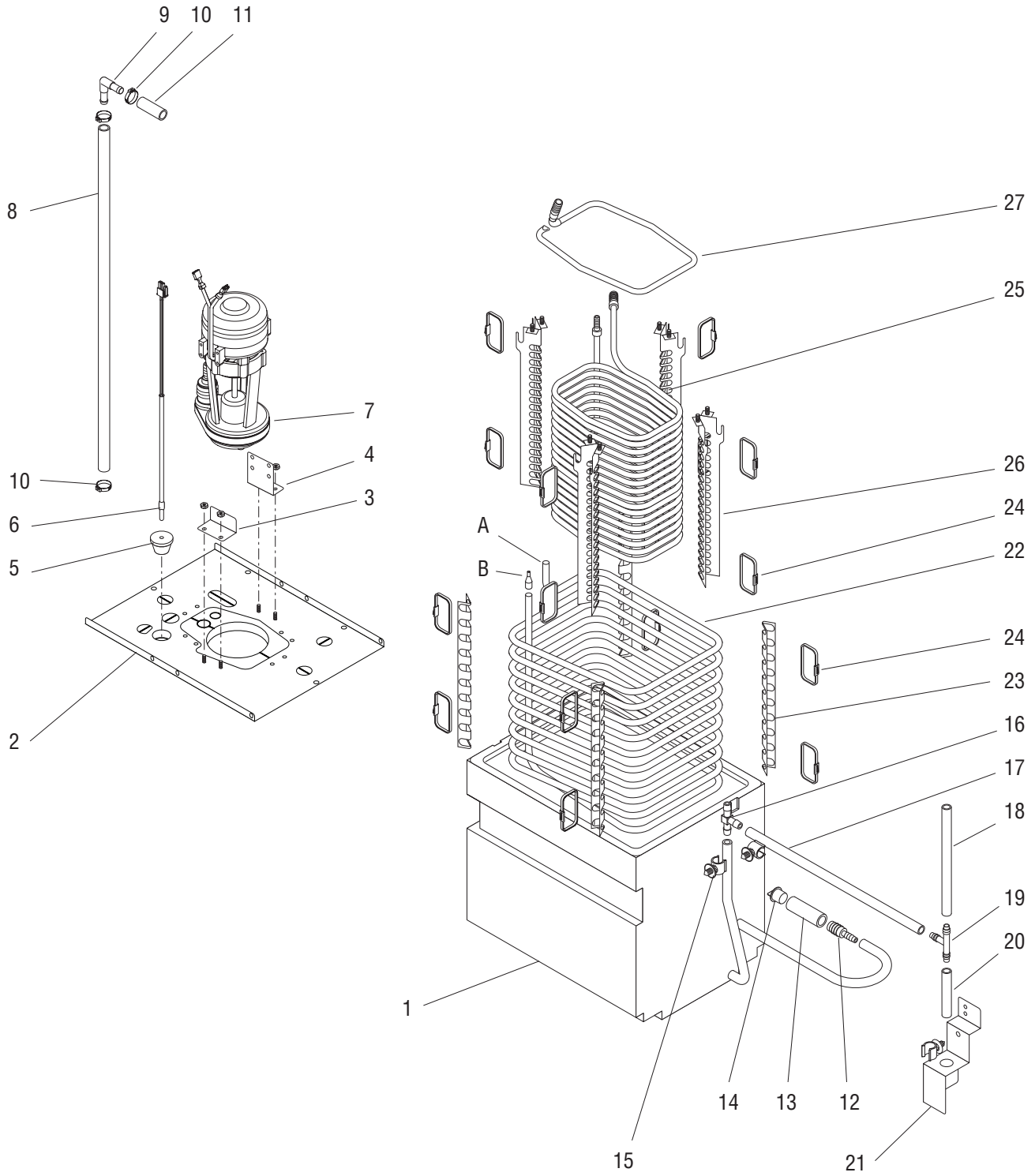

NOTE: Letters appearing within this illustration correspond to matching connections in other illustrations.

P3616

WATER TANK ASSY

ITEM	PART NO.	QTY.	DESCRIPTION
27	38829.0000	1	Manifold, Return Water
28	M2337.1000	-	Insulation, Tube 25/50 .50" ID x 72.0" (Cut to required length)
29	M2336.1000	-	Insulation, Tube 25/50 .38" ID x 72.0" (Cut to required length)
30	34325.1000	-	Hose, Flex .38" ID x .625" OD x 12.0" (Cut to required length)
	34325.1001	-	Hose, Flex .38" ID x .625" OD x 36.0" (Cut to required length)
	34325.1002	-	Hose, Flex .38" ID x .625" OD x 120.0" (Cut to required length)
31	11707.1000	-	Hose, Silicone .25" ID x .625" OD x 12.0" (Cut to required length)
	11707.1001	-	Hose, Silicone .25" ID x .625" OD x 36.0" (Cut to required length)
	11707.1002	-	Hose, Silicone .25" ID x .625" OD x 120.0" (Cut to required length)
32	32591.1001	-	Hose, Silicone .50" ID x .625" OD x 12.0" (Cut to required length)
	32591.1002	-	Hose, Silicone .50" ID x .625" OD x 36.0" (Cut to required length)

* Indicates the part number listed is for reference only. See DESCRIPTION for possible service replacement.

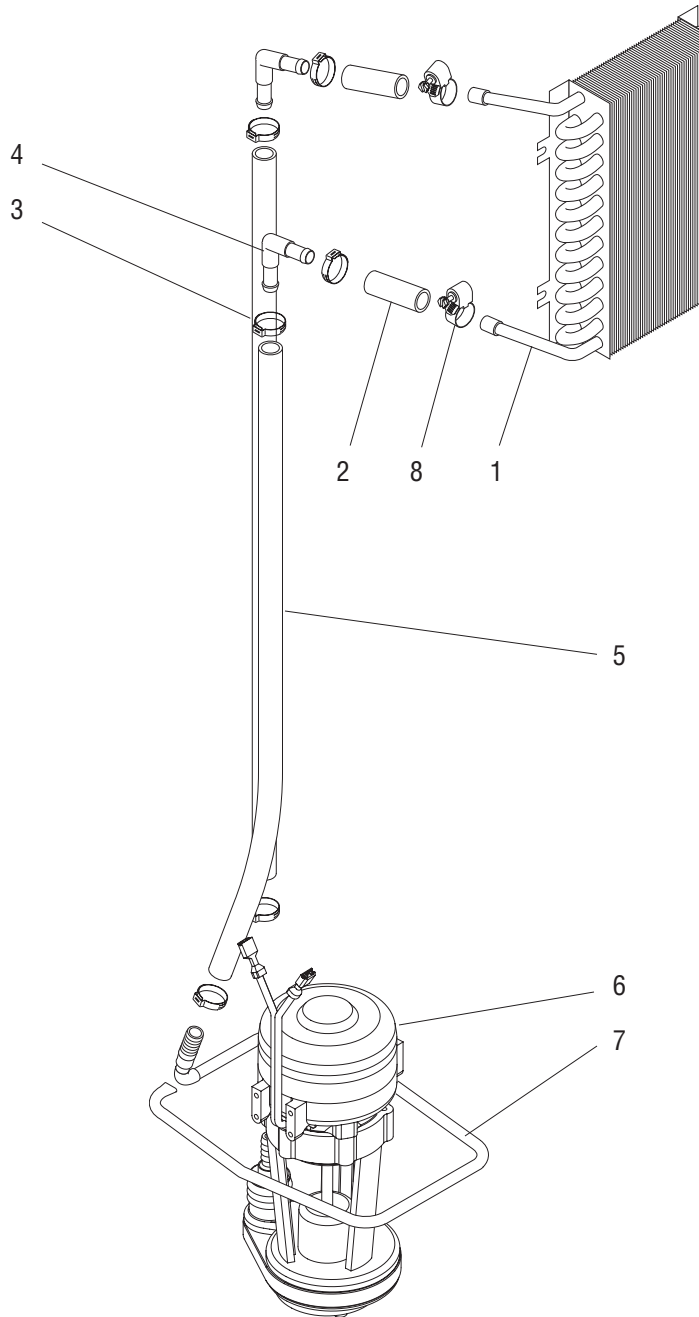

CIRCULATION PUMP & LINES

ITEM	PART NO.	QTY.	DESCRIPTION
1	-----	1	Coil, Upper Cabinet (See UPPER CABINET & PANELS)
2	34325.0004*	1	Tube, Silicone .38" ID x 1.5" (Order item 10)
3	21275.0003	4	Clamp .57" - .70"
4	37850.0000	1	Elbow .38" Barb
5	34325.0010*	1	Tube, Silicone .38" ID x 17.0" (Order item 10)
6	-----	1	Pump, Circulation (See WATER TANK ASSEMBLY)
7	-----	1	Manifold, Return Water (See WATER TANK ASSEMBLY)
8	29421.0000	2	Clamp, Hose Worm Drive .625/.75"
9	M2336.1000	-	Insulation, Tube 25/50 .38" ID x 72.0" (Cut to required length)
10	34325.1000	-	Tube, Silicone .38" ID x 12.0" (Cut to required length)
	34325.1001	-	Tube, Silicone .38" ID x 36.0" (Cut to required length)
	34325.1002	-	Tube, Silicone .38" ID x 120.0" (Cut to required length)

* Indicates the part number listed is for reference only. See DESCRIPTION for possible service replacement.

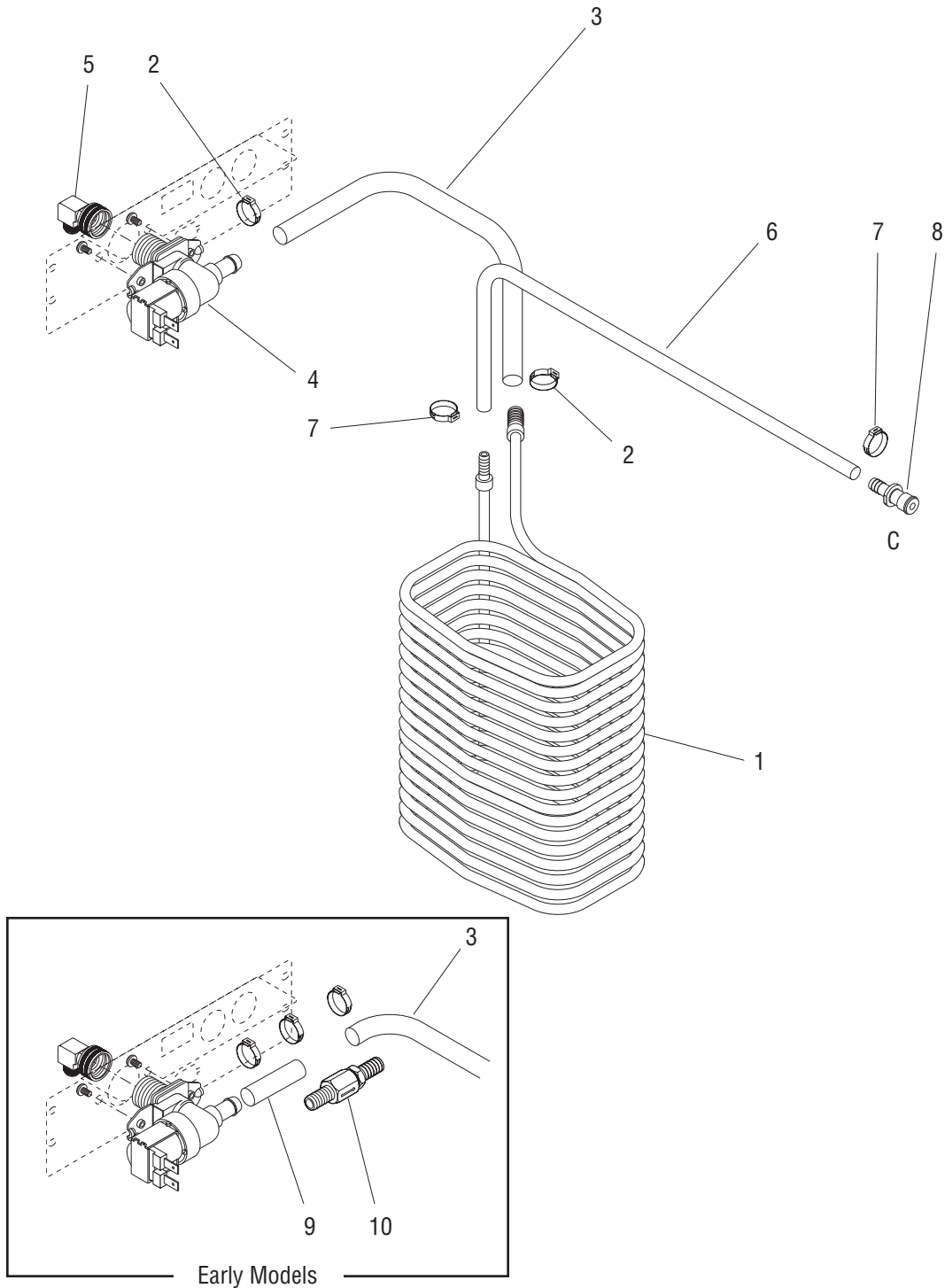

NOTE: Letters appearing within this illustration correspond to matching connections in other illustrations.

PRODUCT COIL & LINES

ITEM	PART NO.	QTY.	DESCRIPTION
1	-----	1	Product Coil (See WATER TANK ASSEMBLY)
2	21275.0003	2	Clamp .57" - .70" (Two additional used on 230V)
3	34325.0029*	1	Hose, Flex .38" ID x 8.75" (Order item 11)(120V)
	34325.0032*	1	Hose, Flex .38" ID x 5.25" (Order item 11)(230V)
4	36233.0005	1	Valve, Water Inlet 120V
	36233.0006	1	Valve, Water Inlet 230V
	32283.0000	2	Screw, Pan Head M4 x 6mm
5	37297.0001	1	Fitting, Elbow .38" FI x .75" Fine Hose (Includes Gasket)
	41640.0000	1	Gasket
6	38129.0008*	1	Hose, Braided .25" ID x 15.75" (Order item 12)
7	21275.0006	2	Clamp .41" - .50"
8	34460.0000	1	Coupling, Quick Disconnect, Male
9	34325.0004*	1	Hose, Flex .38" ID x 1.50" (Order item 11)(230V)
10	40071.0001	1	Check Valve (230V)
11	34325.1000	-	Hose, Flex .38" ID x 12.0" (Cut to required length)
	34325.1001	-	Hose, Flex .38" ID x 36.0" (Cut to required length)
	34325.1002	-	Hose, Flex .38" ID x 120.0" (Cut to required length)
12	38129.1000	1	Hose, Braided .25" ID x 12.0" (Cut to required length)
	38129.1001	1	Hose, Braided .25" ID x 36.0" (Cut to required length)
	38129.1002	1	Hose, Braided .25" ID x 120.0" (Cut to required length)
13	M2336.1000	-	Insulation, Tube 25/50 .38" ID x 72.0" (Cut to required length)

* Indicates the part number listed is for reference only. See DESCRIPTION for possible service replacement.

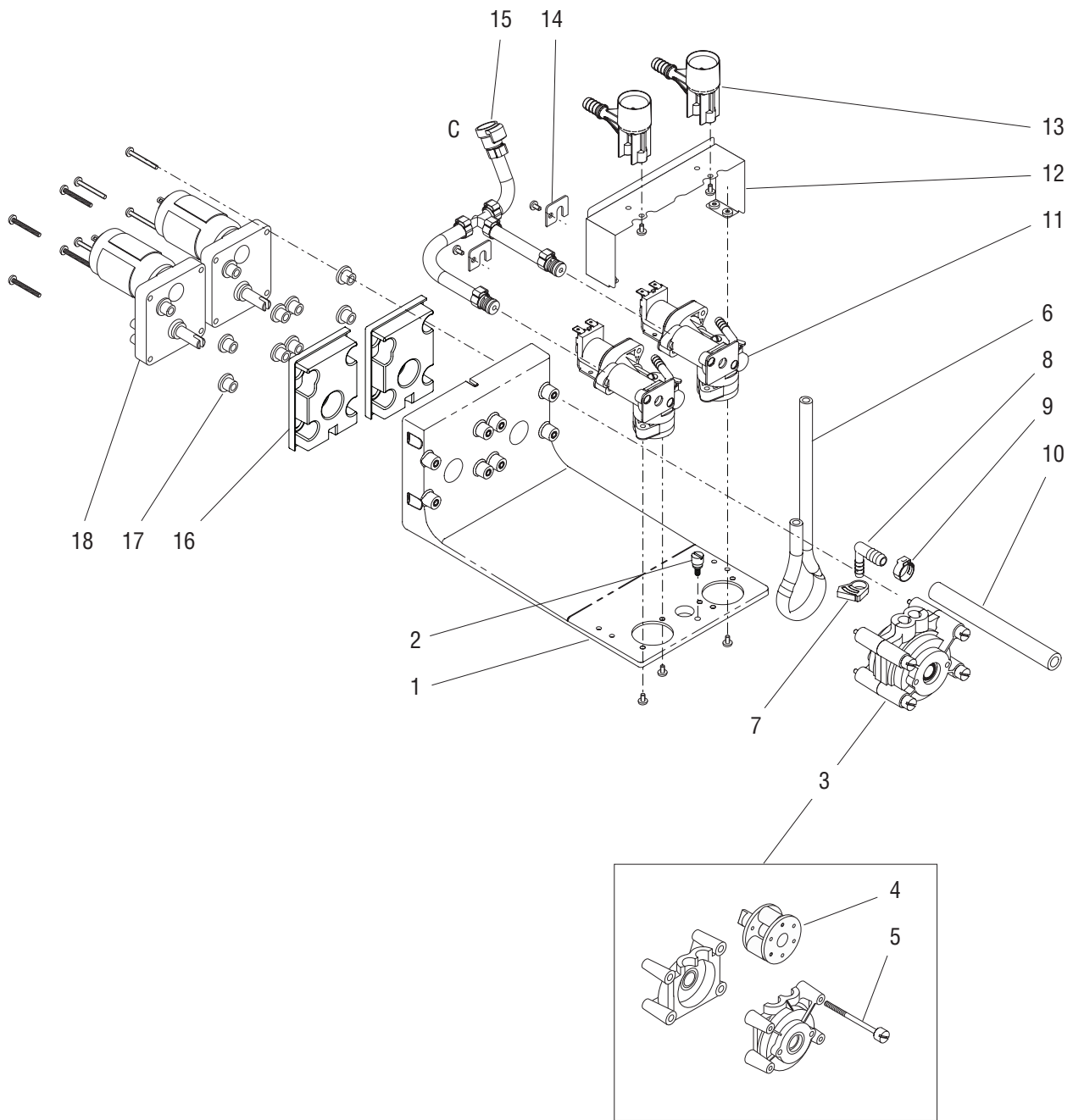

NOTE: Letters appearing within this illustration correspond to matching connections in other illustrations.

DISPENSE PLATFORM ASSEMBLY

ITEM	PART NO.	QTY.	DESCRIPTION
-	38474.1000	1	Platform Assy (Includes items 1 - 19)
1	38121.0001	1	Platform
2	38104.0000	1	Thumbscrew
3	28759.0000	2	Pump Assy (Includes items 4 & 5)
4	28794.0000	2	Rotor
5	01370.0001	8	Screw, Pan Head #8-32 x 2.45"
6	28755.1011	2	Tube, Norprene .25" ID x 17.0" lg
7	32732.0000	2	Clamp .39"/.48"
8	32656.0000	2	Fitting, Elbow .25" Barb x .38" Barb
9	21275.0003	2	Clamp .57"/.70"
10	34325.0032*	2	Hose, Flex .38" ID x 5.25" lg (Order item 20)
11	38018.1000	2	Dispense Valve (See DISPENSE VALVE)
	01308.0000	4	Screw, Truss Head #6-32 x 25"
12	38660.0001	1	Bracket
	01308.0000	4	Screw, Truss Head #6-32 x 25"
13	38120.0001	2	Fitting, Bottle Adapter
	01308.0000	4	Screw, Truss Head #6-32 x 25"
14	37786.0000	2	Plate
	01308.0000	2	Screw, Truss Head #6-32 x 25"
15	-----	1	Manifold, Plain Water (See PLAIN WATER MANIFOLD)
16	33781.0000	2	Gasket
17	32957.0000	8	Bushing, Rubber
18	32613.1003	2	Motor Assy
	01322.0001	4	Screw #8-32 x 1.25"

The following items are not illustrated

19	38873.0000	1	Harness, Dispense Platform
20	34325.1000	-	Hose, Flex .375" ID x 12.0" (Use as required)
	34325.1001	-	Hose, Flex .375" ID x 36.0" (Use as required)
	34325.1002	-	Hose, Flex .375" ID x 120.0" (Use as required)
21	39690.0000	-	Pump Tube (Includes items 6,7,8,9 & 10)

* Indicates the part number listed is for reference only. See DESCRIPTION for possible service replacement.

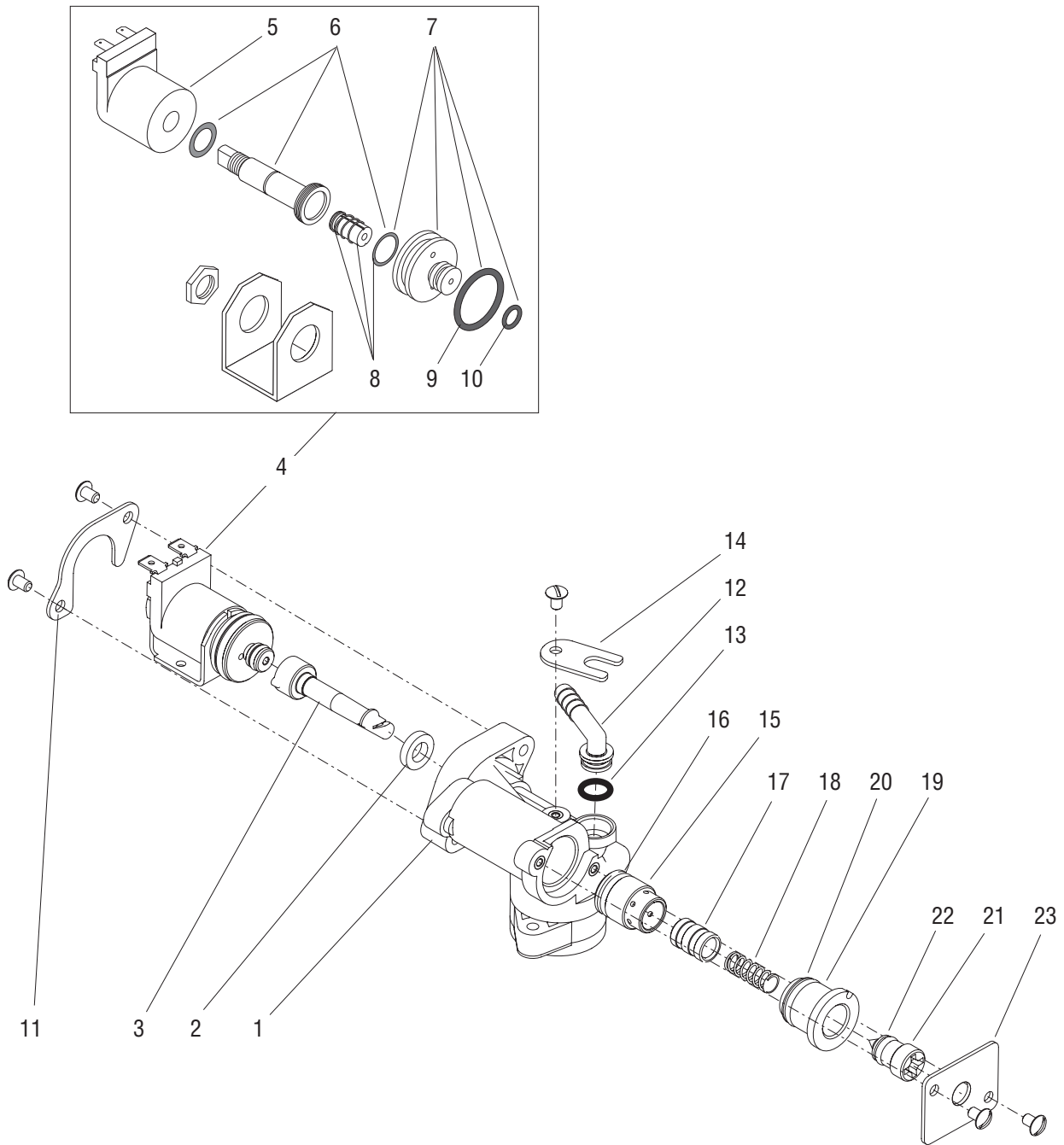

DISPENSE VALVE ASSEMBLY

ITEM	PART NO.	QTY.	DESCRIPTION
-	38018.1000	1	Dispense Valve Assy (Includes items 1 - 24)
1	37801.0001	1	Body
2	37990.0000	1	Seal
3	37843.0000	1	Nozzle, Water
4	32252.0000	1	Valve, Solenoid (Includes items 5 - 10)
5	33554.0000	1	Solenoid Valve Coil
6	28481.0000	1	Guide Kit (Includes Guide, Washer and O-ring)
7	33585.0000	1	Solenoid Valve Base Kit (Includes O-ring and items 6 & 7)
8	01111.0002	1	Solenoid Valve Repair Kit (Includes Plunger, Spring and O-ring)
9	33580.0000	1	O-ring
10	33553.0000	1	O-ring
11	37987.0000	1	Bracket
	01308.0000	2	Screw #6-32 x .25"
12	32463.0000	1	Fitting, Elbow
13	32849.0001	1	O-ring (Also use item 24)
14	37853.0000	1	Clamp
	01308.0000	1	Screw #6-32 x .25"
15	32603.0000	1	Sleeve
16	32852.0000	1	O-ring (Also use item 24)
17	32602.0000	1	Piston
18	32853.0001	1	Spring, Flow Control
19	32624.0000	1	Bonnet, Adjuster
20	33725.0000	1	O-ring (Also use item 24)
21	32623.0000	1	Adjuster, Position
22	32851.0000	1	O-ring (Also use item 24)
23	37977.0000	1	Bracket, Water Adjustment
	01308.0000	2	Screw #6-32 x .25"
24	M2568.1000	-	Grease, USDA H-1 (Use when assembling items 13,16,20 & 22)

* Indicates the part number listed is for reference only. See DESCRIPTION for possible service replacement.

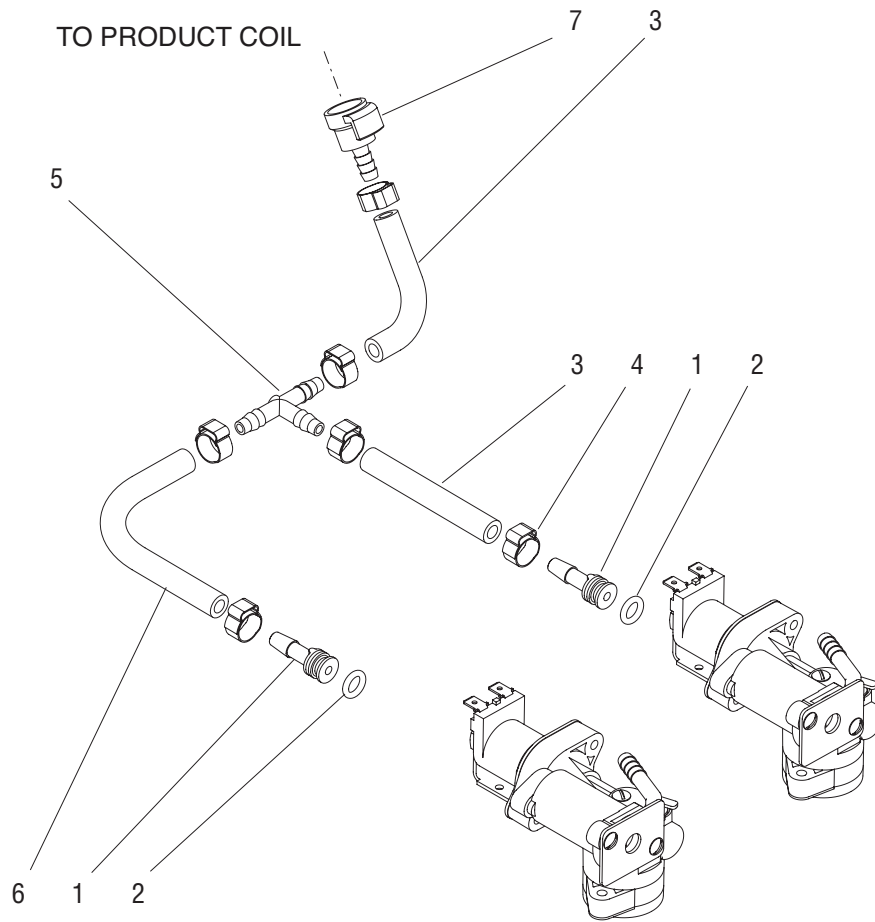

PLAIN WATER MANIFOLD

ITEM	PART NO.	QTY.	DESCRIPTION
1	32631.0000	2	Fitting, Straight
2	32849.0001	2	O-ring
3	38129.0012*	2	Hose, Braided .25" ID x 3.0" (Order item 8)
4	21275.0006	6	Clamp .40 - .50"
5	38605.0000	1	Tee .25" Barb
6	38129.0013*	1	Hose, Braided .25" ID x 5.25" (Order item 8)
7	34461.0000	1	Coupling, Quick Disconnect, Female
8	38129.1000	1	Hose, Braided .25" ID x 12.0" (Cut to required length)
	38129.1001	1	Hose, Braided .25" ID x 36.0" (Cut to required length)
	38129.1002	1	Hose, Braided .25" ID x 120.0" (Cut to required length)

* Indicates the part number listed is for reference only. See DESCRIPTION for possible service replacement.

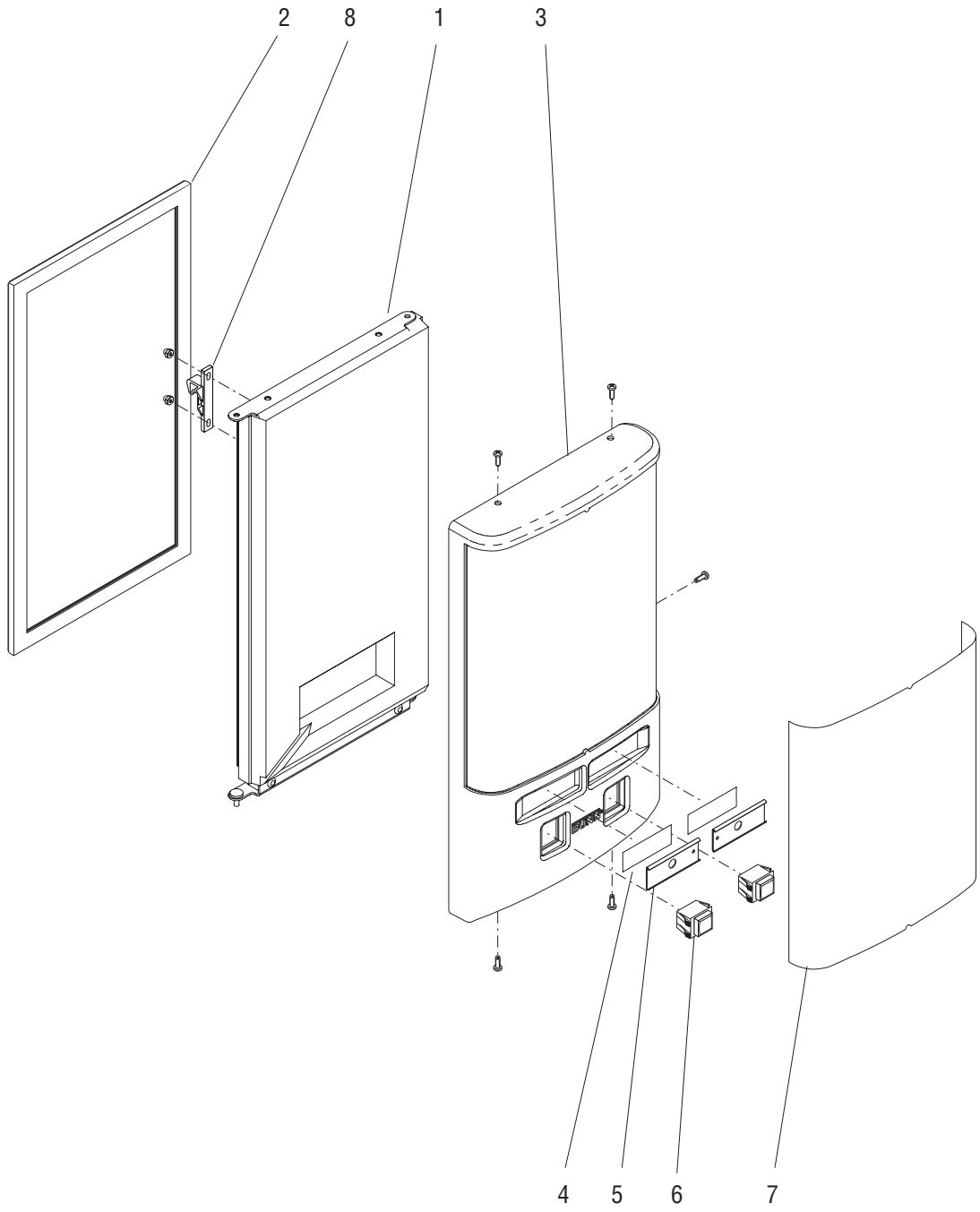

DOOR ASSEMBLY - UNLITED

ITEM	PART NO.	QTY.	DESCRIPTION
1	38485.0000	1	Door, Inner (Includes item 2)
2	38568.0000	1	Gasket, Door
3	38476.0000*	1	Cover, Door Front
	02331.0001	5	Screw, Truss Head, Blk #10-32 x .375"
4	32819.0001	2	Strip, Adhesive
5	37018.0001	2	Flavor Label Holder
6	41719.0000	2	Switch, Dispense
7	38560.0000	1	Decal, Door Wrap (BUNN Juice)
	38560.0001	1	Decal, Door Wrap (BUNN Iced Coffee)
8	34667.0000	1	Keeper, Door Latch
	02319.0000	2	Nut, Acorn
The following items are not illustrated			
9	38871.0000	1	Wiring Harness, Switches
10	32861.0000	-	Decals, Flavor (BUNN Juice)
	32861.0001	-	Decals, Flavor (BUNN Iced Coffee)

* Indicates the part number listed is for reference only. See DESCRIPTION for possible service replacement.

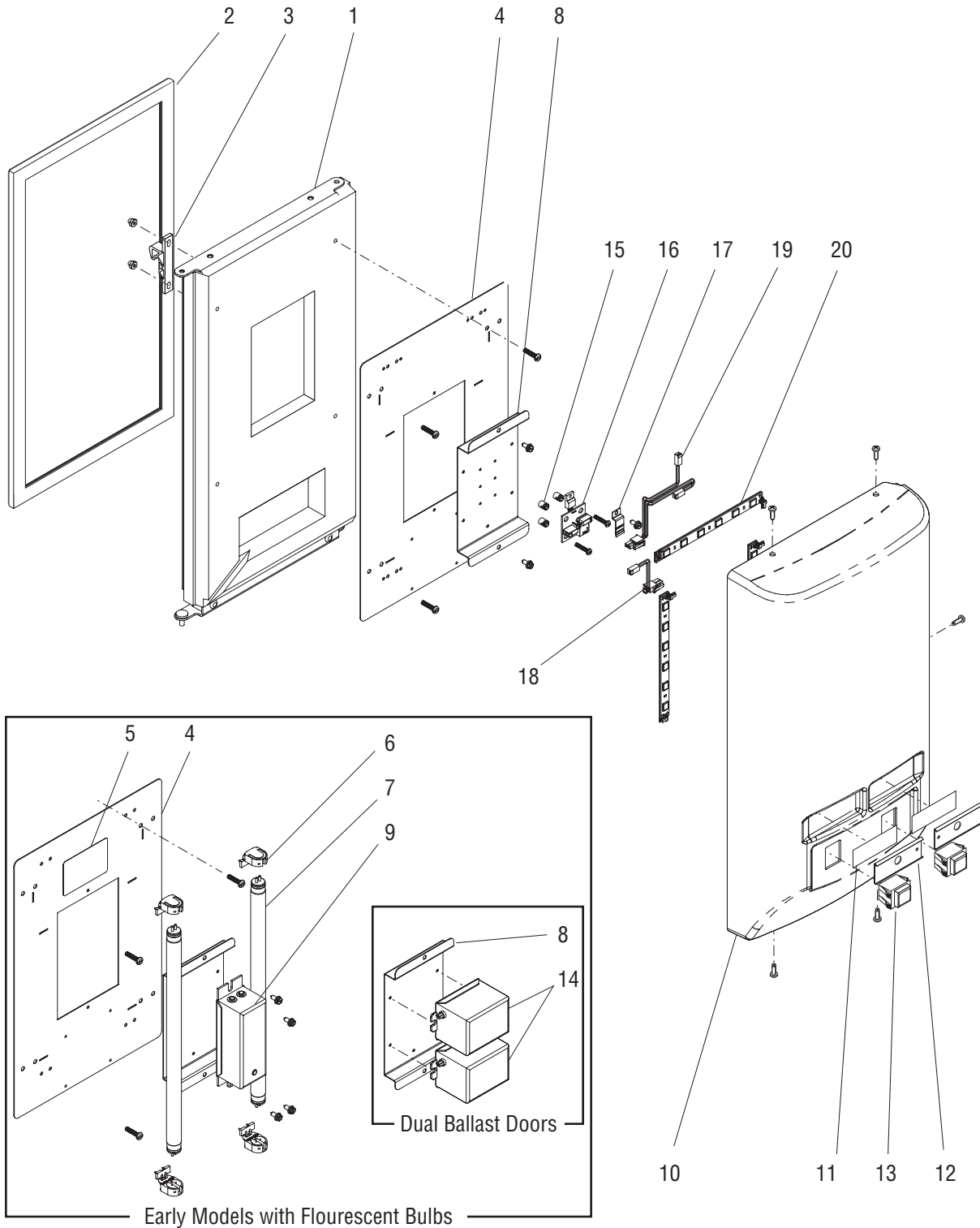

DOOR ASSEMBLY - LITED w/MECHANICAL SWITCHES

ITEM	PART NO.	QTY.	DESCRIPTION
1	38485.0000	1	Door, Inner (Includes item 2)
2	38568.0000	1	Gasket, Door
3	34667.0000	1	Keeper, Door Latch
	02319.0000	2	Nut, Acorn
4	39721.0001	1	Panel, Light
	01370.0000	4	Screw, Pan Head #8-32 x .75"
5	40117.0000	1	Decal, Bulb Replacement (Early Models)
6	27543.0001	4	Lamp Holder (Early Models)
7	26239.0000	2	Lamp, Flourescent (Early Models)
8	40159.0001	1	Bracket
	02335.0001	2	Screw, Hex Crimptite #8 x .38"
9	40307.1000	1	Ballast (Single Ballast Doors)
	02335.0001	2	Screw, Hex Crimptite #8 x .38"
10	39699.0000	1	Cover, Door Front (Juice Display)
	39699.0001	1	Cover, Door Front (Iced Coffee Display)
	02331.0001	5	Screw, Truss Head, Blk #10-32 x .375"
11	32819.0001	2	Strip, Adhesive
12	37018.0001	2	Flavor Label Holder
13	41719.0000	2	Switch, Dispense
14	40307.0001	2	Ballast (Dual Ballast Doors)(Early Models)
	02335.0001	4	Screw, Hex Crimptite #8 x .38"
15	29081.0005	3	Spacer
16	41727.0000	1	Circuit Board
	14002.6300	3	Screw
17	41244.0000	1	Clip, Transducer
18	42609.0000	1	Wiring Harness
19	42609.0001	1	Wiring Harness
20	42593.0000	3	LED

The following items are not illustrated

21	38871.0000	1	Wiring Harness, Switches
22	32861.0000	-	Decals, Flavor (BUNN Juice)
	32861.0001	-	Decals, Flavor (BUNN Iced Coffee)
23	40469.0000	1	Wiring Harness, Ballast (Dual Ballast Doors)(Early Models)
24	21001.0731	4	Lead (For Each Lampholder)(Early Models)

* Indicates the part number listed is for reference only. See DESCRIPTION for possible service replacement.

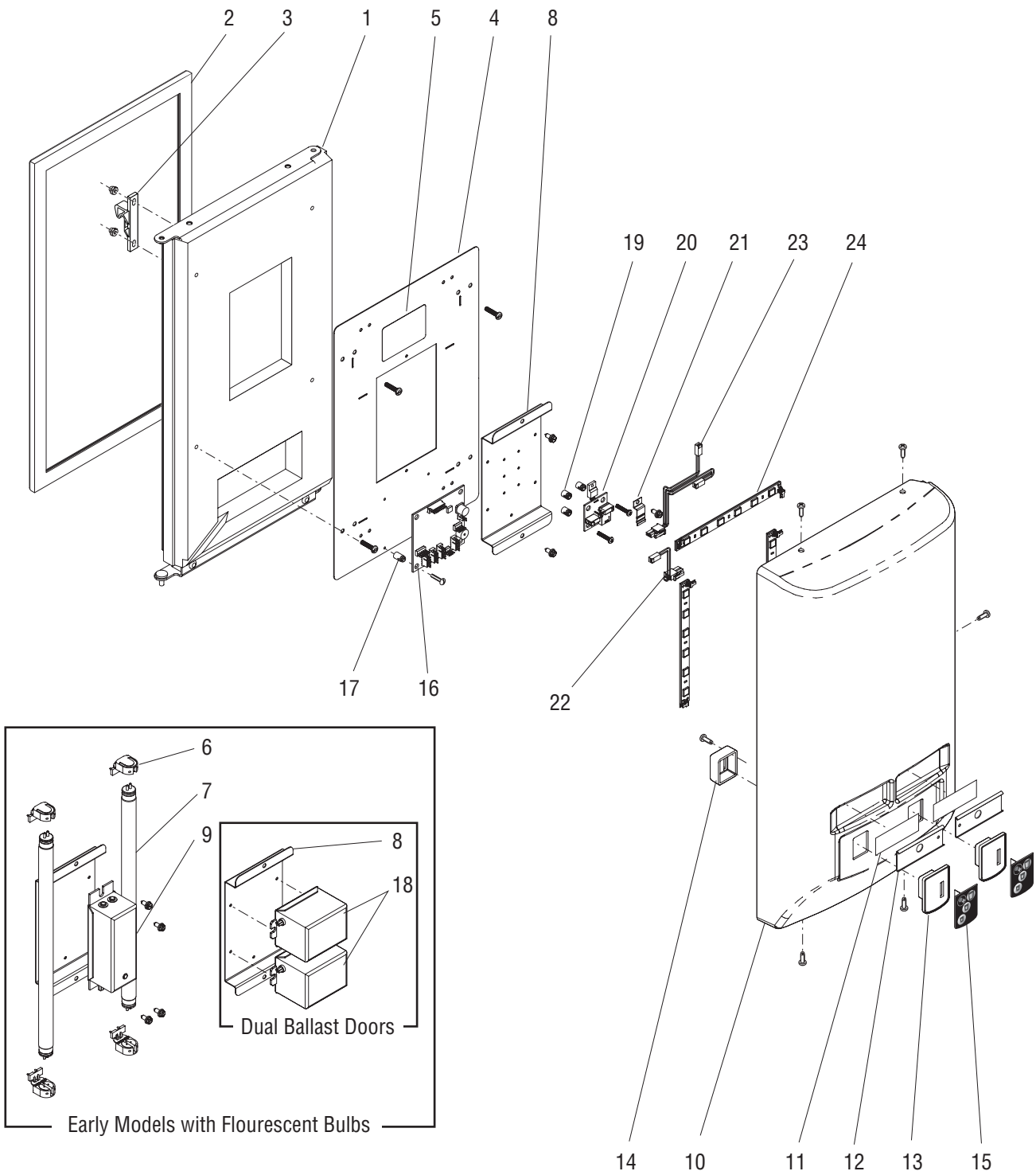

DOOR ASSEMBLY - LITED w/MEMBRANE SWITCHES

ITEM	PART NO.	QTY.	DESCRIPTION
1	38485.0000	1	Door, Inner (Includes item 2)
2	38568.0000	1	Gasket, Door
3	34667.0000 02319.0000	1 2	Keeper, Door Latch Nut, Acorn
4	39721.0001 01370.0000	1 4	Panel, Light Screw, Pan Head #8-32 x .75"
5	40117.0000	1	Decal, Bulb Replacement (Early Models)
6	27543.0001	4	Lamp Holder (Early Models)
7	26239.0000	2	Lamp, Flourescent (Early Models)
8	40159.0001 02335.0001	1 2	Bracket Screw, Hex Crimptite #8 x .38"
9	40307.1000 02335.0001	1 2	Ballast (Single Ballast Doors) Screw, Hex Crimptite #8 x .38"
10	39699.0000 39699.0001 02331.0001	1 1 5	Cover, Door Front (Juice Display) Cover, Door Front (Iced Coffee Display) Screw, Truss Head, Blk #10-32 x .375"
11	32819.0001	2	Strip, Adhesive
12	37018.0001	2	Flavor Label Holder
13	40382.0000	2	Bezel, Switch
14	40381.0000 01360.0001	2 4	Retainer, Bezel Screw, Pan Head #6 x .60"
15	40606.0000 40607.0000	2 2	Membrane Switch (Portion Control Models) Membrane Switch (Push Button Models)
16	40875.0000 14002.6300	1 4	Circuit Board, Portion Control Screw, Pan Head #6-20 x .75"
17	29081.0000	4	Spacer, Circuit Board
18	40307.0001 02335.0001	2 4	Ballast (Dual Ballast Doors)(Early Models) Screw, Hex Crimptite #8 x .38"
19	29081.0005	3	Spacer
20	41727.0000 14002.6300	1 3	Circuit Board Screw
21	41244.0000	1	Clip, Transducer
22	42609.0000	1	Wiring Harness
23	42609.0001	1	Wiring Harness
24	42593.0000	3	LED

The following items are not illustrated

25	41202.0000 41202.0001	1 1	Wiring Harness, Door (Early Models w/ Flourescent Bulbs) Wiring Harness, Door (Late Models w/ LED Lights)
26	32861.0000 32861.0001	- -	Decals, Flavor (BUNN Juice) Decals, Flavor (BUNN Iced Coffee)
27	40469.0000	1	Wiring Harness, Ballast (Dual Ballast Doors) (Early Models)
28	21001.0731	4	Lead (For Each Lampholder) (Early Models)

* Indicates the part number listed is for reference only. See DESCRIPTION for possible service replacement.

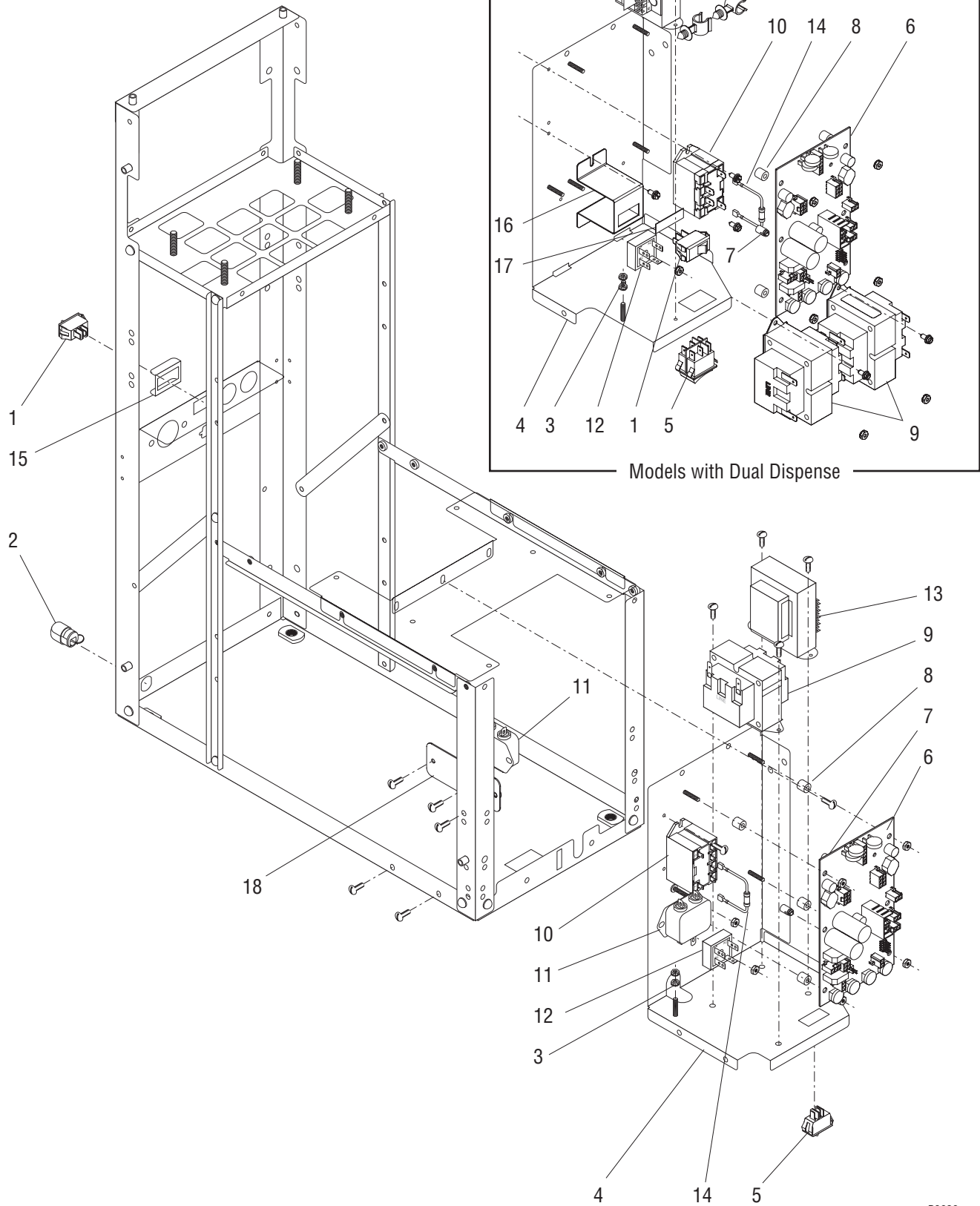

ELECTRICAL COMPONENTS

ITEM	PART NO.	QTY.	DESCRIPTION
1	04786.0002	1	Switch, Compressor ON/OFF
2	00707.0000	1	Bushing, Strain Relief
3	00970.0000	2	Nut, Harness Grounding
4	39797.0000*	1	Enclosure (Standard)
	39797.0001*	1	Enclosure (Models with Dual Dispense)
	02308.0000	4	Screw, Pan Head #8-32 x .38"
5	39720.0000	1	Switch, Dispense Deck ON/OFF
6	40177.1001	1	Circuit Board 120V (Standard)
	40177.1000	1	Circuit Board 120V (Models with Dual Dispense)
	40083.1000	1	Circuit Board 230V
	00973.0000	4	Nut, Keps #6-32
7	29081.0000	2	Spacer
8	01533.0000	4	Spacer
9	39305.0000	1	Transformer 120V (One additional used with Dual Dispense)
	39417.0001	1	Transformer 230V
	02335.0001	2	Screw, Crimptite #8 x .38"
10	37711.0000	1	Relay 120V
	37711.0001	1	Relay 230V
	02335.0001	2	Screw, Crimptite #8 x .38"
11	29446.0000	1	EMI Filter 230V
	02335.0001	2	Screw, Crimptite #8 x .38"
12	22126.0000	1	Rectifier (Lited Doors)
	00973.0000	1	Nut, Keps #6-32
13	28860.0000	1	Transformer 120V (Models w/ Lited Door)
	28860.0001	1	Transformer 230V (Models w/ Lited Door)
	02335.0001	2	Screw, Crimptite #8 x .38"
14	40770.0000	1	Resistor 230V
15	40773.0001	1	Switch Guard (Early Models)
16	41503.0000	1	Bracket, Switch (Models with Dual Dispense)
	02335.0001	1	Screw, Crimptite #8 x .38"
	00973.0000	2	Nut, Keps #6-32
17	41509.0000	1	Decal, Compressor Switch (Models with Dual Dispense)
18	41411.0000	1	Bracket, EMI Filter (Models with Dual Dispense)
	02335.0001	1	Screw, Crimptite #8 x .38"
	02328.0003	2	Screw, Pan Head #6-32 x .312"
	00973.0000	2	Nut, Keps #6-32

The following items are not illustrated

18	20630.0013	1	Power Cord 120V
	27728.0009	1	Power Cord 230V
19	38870.0000	1	Wiring Harness, Transformer to Circuit Bd. (One additional used with Dual Dispense)
20	40118.0000	1	Wiring Harness, Transformer to Circuit Board (Lited Doors)
21	38869.0001	1	Wiring Harness, Main 120V (Models with rear mounted refrigeration switch)
	38869.0001	1	Wiring Harness, Main 120V (Models with front mounted refrigeration switch)
22	38873.0000	1	Wiring Harness, Platform
23	38872.0001	1	Wiring Harness, Unlited Door
	40044.0002	1	Wiring Harness, Lited Door (Models with Flourescent Bulbs)
	40044.0003	1	Wiring Harness, Lited Door (Models with LED Lighting)
24	39198.0000	1	Wiring Harness, EMI Filter 230V
25	41436.0000	1	Wiring Harness, Transformer Jumper (Models with Dual Dispense)
26	41203.0000	1	Wiring Harness, Dispense Disable Switch (Models with Portion Control)

* Indicates the part number listed is for reference only. See DESCRIPTION for possible service replacement.

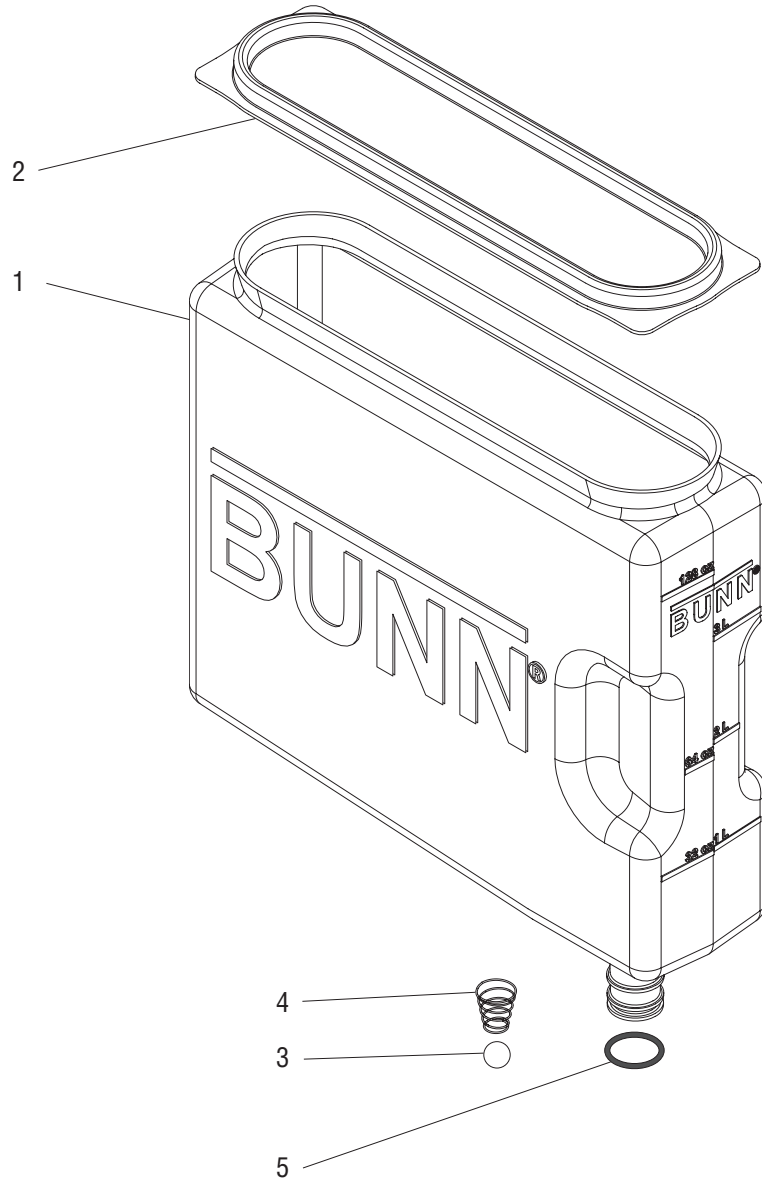

REFILLABLE CONTAINER ASSEMBLY

ITEM	PART NO.	QTY.	DESCRIPTION
-	39302.0000	1	Container Assy (Includes items 1-5)
1	39301.0000*	1	Container
2	39299.0000	1	Lid
3	00598.0002	1	Ball (Early Models)
4	32877.0000	1	Spring (Early Models)
5	34261.0000	1	O-ring

* Indicates the part number listed is for reference only. See DESCRIPTION for possible service replacement.

NUMERICAL INDEX

PART NO.	PAGE NO.	PART NO.	PAGE NO.	PART NO.	PAGE NO.	PART NO.	PAGE NO.
00396.0002.....	9	28755.1011.....	23	34010.0001.....	7	38129.1002.....	21,27
00598.0002.....	37	28759.0000.....	23	34261.0000.....	37	38474.1000.....	23
00656.0000.....	5	28794.0000.....	23	34325.0004.....	15,19,21	38476.0000.....	29
00668.0000.....	5	28860.0000.....	35	34325.0010.....	19	38485.0000.....	29,31,33
00669.0002.....	7	28860.0001.....	35	34325.0013.....	15	38560.0000.....	29
00707.0000.....	35	28891.1000.....	15	34325.0029.....	21	38560.0001.....	29
00901.0000.....	9	29081.0000.....	33,35	34325.0032.....	21,23	38568.0000.....	29,31,33
00970.0000.....	35	29081.0005.....	31,33	34325.1000.....	17,19,21,23	38605.0000.....	15,27
00973.0000.....	35	29421.0000.....	19	34325.1001.....	17,19,21,23	38606.0000.....	5
00973.0001.....	15	29446.0000.....	35	34325.1002.....	17,19,21,23	38606.0001.....	5
00986.7000.....	5	29951.0002.....	9	34362.0002.....	7	38615.0000.....	5
01111.0002.....	25	32204.1001.....	13	34416.0000.....	15	38615.00001.....	5
01308.0000.....	23,25	32204.1002.....	13	34418.0001.....	9	38616.0000.....	7
01322.0001.....	23	32252.0000.....	25	34419.0001.....	7	38617.0000.....	5
01359.0000.....	7	32283.0000.....	21	34421.0001.....	7	38654.0000.....	5
01360.0001.....	33	32461.0000.....	7	34422.0003.....	7	38660.0001.....	23
01370.0000.....	31,33	32463.0000.....	25	34460.0000.....	21	38661.0000.....	5
01370.0001.....	23	32591.0014.....	15	34461.0000.....	27	38662.0000.....	15
01388.0000.....	7	32591.1001.....	17	34529.0000.....	9	38716.1001.....	5
01512.0000.....	5	32591.1002.....	17	34666.0001.....	7	38717.1001.....	5
01533.0000.....	35	32602.0000.....	25	34667.0000.....	29,31,33	38718.1003.....	5
02308.0000.....	5,7,9,15,35	32603.0000.....	25	34738.0001.....	7	38719.1001.....	5
02319.0000.....	29,31,33	32613.1003.....	23	34741.0000.....	7	38765.1000.....	5
02328.0003.....	35	32623.0000.....	25	34784.0000.....	7	38827.0000.....	15
02331.0001.....	5,7,29,31,33	32624.0000.....	25	34785.0001.....	7	38827.0001.....	15
02335.0001.....	5,9,31,33,35	32631.0000.....	27	34790.0001.....	7	38828.0000.....	15
03996.0000.....	5	32656.0000.....	23	34790.0002.....	7	38829.0000.....	17
04786.0002.....	35	32732.0000.....	23	35108.1000.....	7	38833.0000.....	15
11707.0009.....	15	32776.0000.....	9	35164.1001.....	9	38833.0001.....	15
11707.0016.....	15	32819.0001.....	29,31,33	35165.0003.....	15	38857.0000.....	7
11707.0043.....	15	32848.0000.....	7	35175.1002.....	9	38869.0001.....	35
11707.0044.....	7	32849.0001.....	25,27	35178.0000.....	9	38869.0002.....	35
11707.1000.....	7,17	32851.0000.....	25	35272.0002.....	15	38870.0000.....	35
11707.1001.....	17	32852.0000.....	25	35930.0000.....	7	38871.0000.....	29,31
11707.1002.....	17	32853.0001.....	25	36233.0005.....	21	38872.0001.....	35
14002.6300.....	31,33	32861.0000.....	29,31,33	36233.0006.....	21	38873.0000.....	23,35
20630.0013.....	35	32861.0001.....	29,31,33	36329.0002.....	15	38896.0000.....	11
21001.0731.....	31,33	32877.0000.....	37	37018.0001.....	29,31,33	38897.0000.....	11
21275.0003.....	15,19,21,23	32957.0000.....	23	37297.0001.....	21	38897.0001.....	11
21275.0006.....	21,27	33153.0000.....	15	37711.0000.....	35	38916.0000.....	11
21436.0000.....	5	33297.0000.....	7	37711.0001.....	35	38917.0000.....	11
22126.0000.....	35	33458.0001.....	5	37786.0000.....	23	38918.0000.....	11
23700.0000.....	13	33461.0001.....	5	37801.0001.....	25	38921.0001.....	9
24544.0000.....	7,15	33519.0001.....	15	37843.0000.....	25	38922.0001.....	9
26239.0000.....	31,33	33522.1002.....	11	37850.0000.....	15,19	38924.0000.....	15
26528.0000.....	5	33522.1003.....	11	37853.0000.....	25	38925.0000.....	15
26801.0000.....	5	33533.0000.....	15	37977.0000.....	25	38934.0001.....	9
27243.0000.....	9,15	33553.0000.....	25	37987.0000.....	25	38937.0001.....	9
27246.0000.....	7	33554.0000.....	25	37990.0000.....	25	38950.0000.....	5
27258.0000.....	13	33580.0000.....	25	38018.1000.....	23,25	38951.0000.....	5
27354.0000.....	5	33585.0000.....	25	38104.0000.....	23	39086.0000.....	7
27394.0000.....	7	33602.0000.....	13	38120.0001.....	23	39198.0000.....	35
27410.0000.....	15	33603.0000.....	13	38121.0001.....	23	39227.0001.....	9
27442.7000.....	5	33603.0001.....	13	38129.0008.....	21	39299.0000.....	37
27543.0001.....	31,33	33669.0000.....	7	38129.0012.....	27	39301.0000.....	37
27728.0009.....	35	33725.0000.....	25	38129.0013.....	27	39302.0000.....	37
28481.0000.....	25	33781.0000.....	23	38129.1000.....	21,27	39305.0000.....	35
28567.0000.....	9	33801.0001.....	15	38129.1001.....	21,27	39417.0001.....	35

NUMERICAL INDEX

PART NO.	PAGE NO.	PART NO.	PAGE NO.	PART NO.	PAGE NO.	PART NO.	PAGE NO.
39491.1002.....	5	M2337.1000	17				
39491.1003.....	5	M2546.1000	9				
39690.0000.....	23	M2550.0001	7				
39699.0000.....	31,33	M2568.1000	25				
39699.0001.....	31,33						
39720.0000.....	35						
39721.0001.....	31,33						
39797.0000.....	35						
39797.0001.....	35						
39907.0000.....	11						
39908.0002.....	11						
39908.0003.....	11						
39912.0002.....	11						
39912.0003.....	11						
40044.0002.....	35						
40044.0003.....	35						
40071.0001.....	21						
40083.1000.....	35						
40117.0000.....	31,33						
40118.0000.....	35						
40159.0001.....	31,33						
40177.1000.....	35						
40177.1001.....	35						
40307.0001.....	31,33						
40307.1000.....	31,33						
40381.0000.....	33						
40382.0000.....	33						
40469.0000.....	31,33						
40606.0000.....	33						
40607.0000.....	33						
40620.0000.....	7						
40770.0000.....	35						
40773.0001.....	35						
40875.0000.....	33						
41103.1000.....	7						
41103.1001.....	7						
41103.1002.....	7						
41103.1003.....	7						
41202.0000.....	33						
41202.0001.....	33						
41203.0000.....	35						
41244.0000.....	31,33						
41385.0000.....	7						
41396.0000.....	11						
41397.0000.....	11						
41398.0000.....	11						
41411.0000.....	35						
41436.0000.....	35						
41503.0000.....	35						
41509.0000.....	35						
41640.0000.....	21						
41719.0000.....	29,31						
41727.0000.....	31,33						
42478.1001.....	5						
42593.0000.....	31,33						
42609.0000.....	31,33						
42609.0001.....	31,33						
M2336.1000	9,17,19,21						