

# **BUNN**®

## **G9-2 HD G9-2T HD G9-2 HD-S**

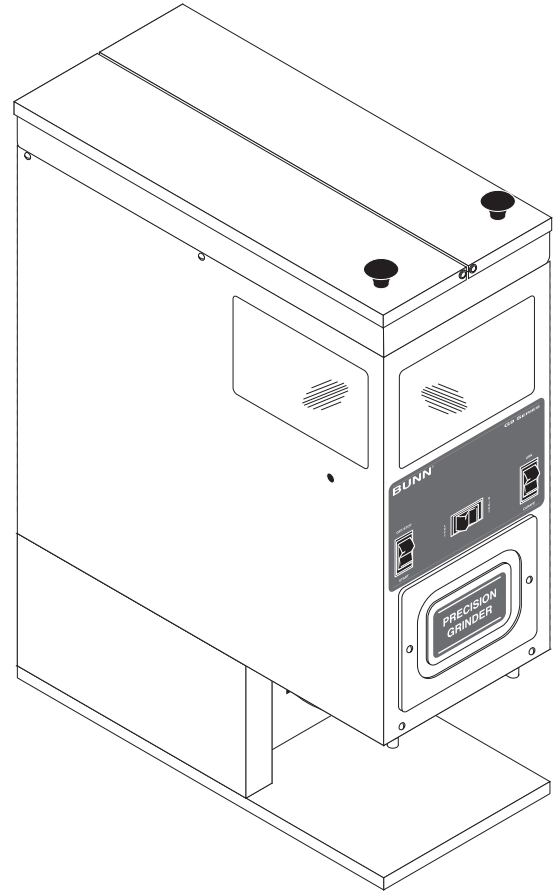
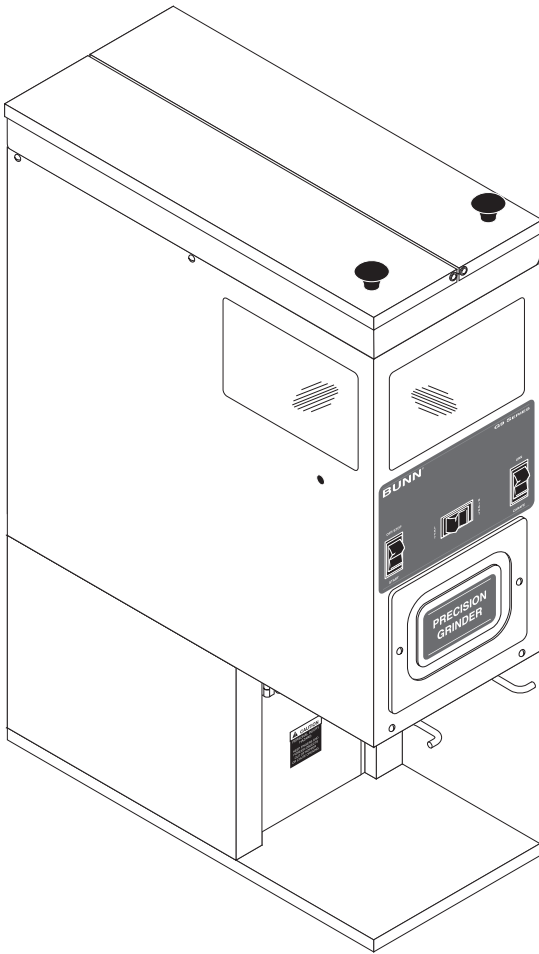

## **OPERATING & SERVICE MANUAL**

**BUNN-O-MATIC CORPORATION**

POST OFFICE BOX 3227

SPRINGFIELD, ILLINOIS 62708-3227

PHONE: (217) 529-6601 FAX: (217) 529-6644

To obtain the Illustrated Parts Catalog, visit the Bunn-O-Matic website, at [www.bunn.com](http://www.bunn.com). This is absolutely FREE, and the quickest way to obtain the catalog. Contact Bunn-O-Matic Corporation at 1-800-286-6070 to obtain a paper copy of the required Illustrated Parts Catalog mailed via U.S. Postal Service.

# CONTENTS

Introduction.....	2
Warranty.....	2
User Notices.....	3
Electrical Requirements.....	4
Operating Controls.....	4
Initial Set-Up.....	4
Cleaning.....	5
Coffee Grinding.....	5
Adjustments.....	6
Troubleshooting.....	7
Service.....	10
Wiring Diagram.....	22

## INTRODUCTION

This equipment will store up-to six pounds of whole bean coffee in each of two hoppers and grind it to a preset grind and amount into an awaiting funnel and filter from most commercial drip coffee brewers. The equipment is only for indoor use on a sturdy counter or shelf. Adequate space must be available above the grinder to raise the lids when adding beans. Use only with whole bean coffee.

The grind is preset at the factory to **drip** specifications as set forth by the United States Department of Commerce and adopted by the Coffee Brewing Center of the Pan American Coffee Bureau. Adjustments may be made to alter both the amount and grind from the factory setting.

## BUNN-O-MATIC COMMERCIAL PRODUCT WARRANTY

Bunn-O-Matic Corp. (“BUNN”) warrants equipment manufactured by it as follows:

- 1) All equipment other than as specified below: 2 years parts and 1 year labor.
- 2) Electronic circuit and/or control boards: parts and labor for 3 years.
- 3) Compressors on refrigeration equipment: 5 years parts and 1 year labor.
- 4) Grinding burrs on coffee grinding equipment to grind coffee to meet original factory screen sieve analysis: parts and labor for 3 years or 30,000 pounds of coffee, whichever comes first.

These warranty periods run from the date of installation BUNN warrants that the equipment manufactured by it will be commercially free of defects in material and workmanship existing at the time of manufacture and appearing within the applicable warranty period. This warranty does not apply to any equipment, component or part that was not manufactured by BUNN or that, in BUNN’s judgment, has been affected by misuse, neglect, alteration, improper installation or operation, improper maintenance or repair, damage or casualty. This warranty is conditioned on the Buyer 1) giving BUNN prompt notice of any claim to be made under this warranty by telephone at (217) 529-6601 or by writing to Post Office Box 3227, Springfield, Illinois 62708-3227; 2) if requested by BUNN, shipping the defective equipment prepaid to an authorized BUNN service location; and 3) receiving prior authorization from BUNN that the defective equipment is under warranty.

**THE FOREGOING WARRANTY IS EXCLUSIVE AND IS IN LIEU OF ANY OTHER WARRANTY, WRITTEN OR ORAL, EXPRESS OR IMPLIED, INCLUDING, BUT NOT LIMITED TO, ANY IMPLIED WARRANTY OF EITHER MERCHANTABILITY OR FITNESS FOR A PARTICULAR PURPOSE.** The agents, dealers or employees of BUNN are not authorized to make modifications to this warranty or to make additional warranties that are binding on BUNN. Accordingly, statements by such individuals, whether oral or written, do not constitute warranties and should not be relied upon.

If BUNN determines in its sole discretion that the equipment does not conform to the warranty, BUNN, at its exclusive option while the equipment is under warranty, shall either 1) provide at no charge replacement parts and/or labor (during the applicable parts and labor warranty periods specified above) to repair the defective components, provided that this repair is done by a BUNN Authorized Service Representative; or 2) shall replace the equipment or refund the purchase price for the equipment.

**THE BUYER’S REMEDY AGAINST BUNN FOR THE BREACH OF ANY OBLIGATION ARISING OUT OF THE SALE OF THIS EQUIPMENT, WHETHER DERIVED FROM WARRANTY OR OTHERWISE, SHALL BE LIMITED, AT BUNN’S SOLE OPTION AS SPECIFIED HEREIN, TO REPAIR, REPLACEMENT OR REFUND.**

In no event shall BUNN be liable for any other damage or loss, including, but not limited to, lost profits, lost sales, loss of use of equipment, claims of Buyer’s customers, cost of capital, cost of down time, cost of substitute equipment, facilities or services, or any other special, incidental or consequential damages.

# USER NOTICES

Carefully read and follow all notices on the grinder and in this manual. They were written for your protection. All notices on the grinder are to be kept in good condition. Replace any unreadable or damaged labels.

**⚠ WARNING**

To reduce the risk of electric shock, do not remove or open cover. No user-serviceable parts inside. Authorized service personnel only. Disconnect power before servicing.

#37881.0000

**⚠ CAUTION**

PERSONAL INJURY HAZARD.

KEEP FINGERS AND FOREIGN OBJECTS OUT OF HOPPER OR CHUTE OPENING.

#05876.0000

**⚠ WARNING**

- ◆ Use only on a properly protected circuit capable of the rated load.
- ◆ Electrically ground the chassis.
- ◆ Follow national/local electrical codes.
- ◆ Do not use near combustibles.

An extension cord, when used, must be shorter than 20 feet if 16-gage 3-conductor wire, or shorter than 10 feet if 18-gage 3-conductor wire.

**FAILURE TO COMPLY RISKS EQUIPMENT DAMAGE, FIRE, OR SHOCK HAZARD**

READ THE ENTIRE OPERATING MANUAL INCLUDING THE LIMIT OF WARRANTY AND LIABILITY BEFORE BUYING OR USING THIS PRODUCT

20545-0000D 01/04 © 1990 Bunn-O-Matic Corporation

#20545.0000

**DISPENSE TIME (Seconds)**

Readout will be displayed for 5 minutes. Timer can only be adjusted while readout is displayed.

**WARNING HAZARDOUS VOLTAGE**

UNPLUG GRINDER BEFORE REMOVING!

#05942.0000

**DISPENSE TIME (SECONDS)**

**WARNING HAZARDOUS VOLTAGE**

UNPLUG GRINDER BEFORE REMOVING

#25763.0000

## ELECTRICAL REQUIREMENTS

This grinder has an attached cordset and requires 2-wire, grounded service rated 120 volts ac, 15 amp, single phase, 60 Hz for 120V models and 230 volts ac, 10 amp single phase, 50 Hz for 230V models..

## OPERATING CONTROLS

### Off/On/Start Switch

**OFF** - (upper position) Switching to this position stops all operation of the grinder.

**ON** - (middle position) The switch will return to this position after a grind cycle has begun and will remain in this position after grinding has ceased.

**START** - (lower, momentary position) Pressing the switch initiates a timed grind cycle.

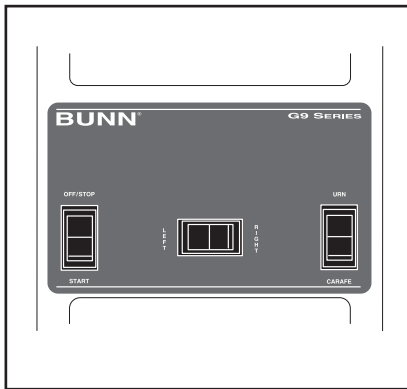

P633

### Hopper Selector Switch

**Left** - Switching to this position allows beans to be dispensed from the left hopper.

**Right** - Switching to this position allows beans to be dispensed from the right hopper.

### Batch Selector Switch (Optional)

**Urn** - Switching to this position allows the correct amount of beans to be dispensed when grinding a large batch.

**CARAFE** - Switching to this position allows the correct amount of beans to be dispensed when grinding a small batch.

## Dispense Timer

The dispense timer controls the amount of beans that will leave the hopper in a grind cycle. The timer can be adjusted to dispense a different amount from each hopper. The scale is from 0.4 to 150.0 seconds. Refer to the Adjustments section for timer setting chart (page 7).

## INITIAL SET-UP

1. Open the top lid. Clear all foreign objects and shipping material from the hopper compartment and the entrance to the grind chamber.
2. Remove the lower front inspection panel.
3. Plug-in the grinder.
4. Select either the right or left hopper with the selector switch. Do not press the start switch.
5. If grinder has an analog timer, proceed to step 6. If grinder has a digital timer, momentarily press the center (DISPLAY) button on the dispense timer panel. The readout will indicate the present timer setting in seconds and will remain displayed for five minutes.
6. Adjust the timer setting to obtain the desired amount of coffee for the selected hopper.
7. Repeat steps 4 thru 6 for the other hopper.
8. Fill the hopper compartments with whole bean coffee. (Capacity 6 pounds each). The grinder is now ready for use.

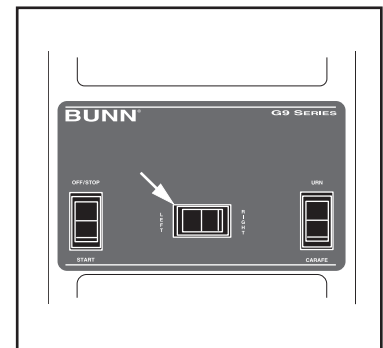

P596

## CLEANING

The use of a damp cloth rinsed in any mild, non-abrasive, liquid detergent is recommended for cleaning all surfaces on Bunn-O-Matic equipment. Care should be taken not to scratch the hopper or windows with any abrasive material. Regular cleaning will keep your grinder looking new for years.

## COFFEE GRINDING

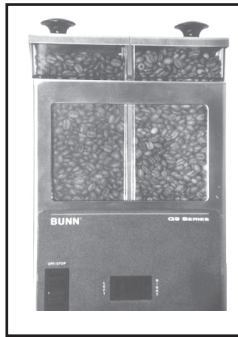

P597

STEP 1



P598

STEP 2

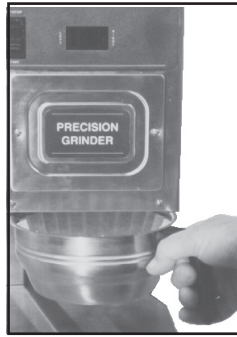

P599

STEP 3

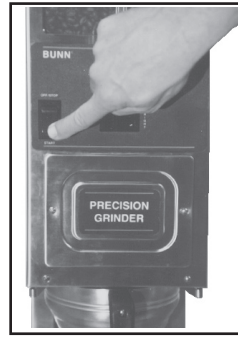

P600

STEP 4



P601

STEPS 5 & 6

1. Visually inspect the selected hopper for an ample supply of whole bean coffee.
2. Place a paper filter into the brew funnel. The filter must not be folded-over or tilted to one side.
3. Insert the funnel into the funnel rails and push until it stops.
4. Momentarily press the start switch. The grinding action will stop automatically after the preset amount of ground coffee is dispensed into the funnel.
5. Remove the funnel from the grinder and level the bed of grounds by gently shaking.
6. The loaded funnel is now ready for use in any commercial drip coffee brewer according to the manufacturer's instructions.

## ADJUSTMENTS

The grind can be set from very fine to very coarse. The amount may be adjusted for use in most commercial coffee brewers. The following procedures should be used to make adjustments. A change in the burr adjustment will also change the amount dispensed. Any adjustment of the burrs should be followed by an adjustment of the timer.

### Burr Adjustment

1. Unplug the grinder and empty all beans from the hoppers.
2. Plug-in the grinder, momentarily press the off/on/start switch to the "START" (lower) position (with either hopper selected) and release, run a few grind cycles until all of the coffee in the grind chamber is used-up.
3. Remove the upper front inspection panel.
4. Early Models only, loosen the burr adjustment screw from its locked position.
5. Early Models only, hand loosen the adjustment locking nut around the screw approximately one turn.
6. Press the off/on/start switch to the "START" (lower) position and release, slowly turn the adjusting screw in a clockwise direction until a metallic whine is heard due to the rubbing of the grinding burrs. (It may be necessary to start more than one grind cycle to obtain this sound.)
7. Make a mark with a pen on the decal to note the position of the arrow on the grind adjustment screw.
8. The following settings approximately correspond to the CBC recognized grinds. All are referenced from the arrow position noted in #7.

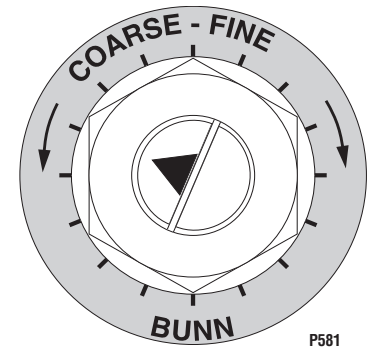

P581

Early Models

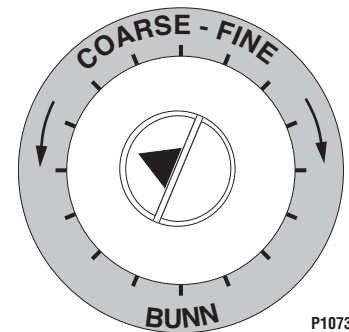

P1073

Late Models

**FINE GRIND:** Rotate the adjusting screw 7 hash marks in a counterclockwise direction.

**DRIP GRIND:** Rotate the adjusting screw 8 hash marks in a counterclockwise direction.

**REGULAR (COARSE) GRIND:** Rotate the adjusting screw 12 hash marks in a counterclockwise direction.

9. Early Models only, hold the adjusting screw in its set position with a screwdriver while tightening the lock nut to a snug position by hand. Slightly loosen the adjusting screw and retighten it to its prior position. The lock nut should now be tight against the burr housing front cover.

### Timer Adjustment

1. Unplug the grinder and remove the lower front inspection panel.
2. Determine the grind setting. (The factory setting is **drip**, to determine other settings, refer to the previous section.)

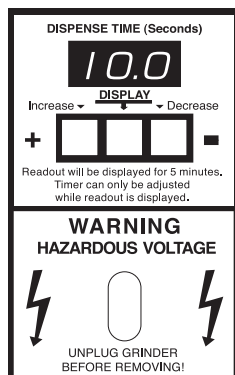

DIGITAL TIMER

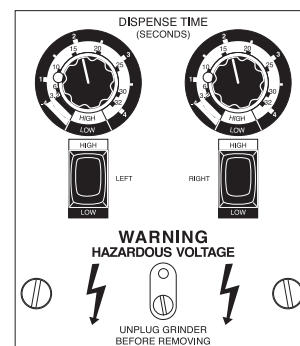

ANALOG TIMER

P595

## ADJUSTMENTS (cont.)

- Use the table on the next page to find approximate timer setting for the grind and amount of coffee desired.
- Plug-in the grinder. Select either the right or left hopper with the selector switch. Do not press the start switch.
- If grinder has an analog timer, proceed to step 6. If grinder has a digital timer, momentarily press the center (DISPLAY) button on the dispense timer panel. The readout will indicate the present timer setting in seconds and will remain displayed for five minutes.
- Adjust the timer setting to obtain the desired amount of coffee for the selected hopper.
- Verify the setting by weighing a few samples. Use the following table as an approximate guide only.
- Repeat steps 4 thru 7 for the other hopper.

### APPROXIMATE TIMER SETTINGS IN SECONDS

Weight (ounces)	Fine (7*)	Drip (8*)	Regular (12*)
1.5	0.5	0.5	0.5
1.75	0.7	0.6	0.6
2.0	1.0	0.8	0.8
2.25	1.4	1.4	1.2
2.5	1.9	1.8	1.6
2.75	2.4	2.2	2.0
3.0	2.9	2.7	2.5
3.25	3.3	3.1	2.9
4.0	4.8	4.4	4.0
6.0	8.6	7.9	7.5
8.0	12.0	11.5	10.9
10.0	15.7	15.1	14.1
12.0	19.6	18.5	17.5
14.0	23.5	22.0	20.9
16.0	27.0	25.3	24.3

\*Hash mark settings. Refer to *Adjustment-Burr* section.

## TROUBLESHOOTING

A troubleshooting guide is provided to suggest probable causes and remedies for the most likely problems encountered. If the problem remains after exhausting the troubleshooting steps, contact the Bunn-O-Matic Technical Service Department.

- Inspection, testing, and repair of electrical equipment should be performed only by qualified service personnel.
- All electronic components have ac voltage and dc voltage potential on their terminals. Shorting of terminals or the application of external voltages may result in board failure.
- Intermittent operation of electronic circuit boards is unlikely. Board failure will normally be permanent. If an intermittent condition is encountered, the cause will likely be a switch contact or a loose connection at a terminal or crimp.
- Make certain that all electrical connections are tight and isolated.

## WARNING

- Exercise extreme caution when servicing electrical equipment.
- Turn power OFF when servicing, except when electrical tests are specified.
- Follow recommended service procedures.
- Replace all protective shields or safety notices.

## TROUBLESHOOTING (cont.)

<b>Problem</b>	<b>Probable Cause</b>	<b>Remedy</b>
Grinder will not start.	1. No power or incorrect voltage	(A) Plug-in the grinder.  (B) Check the voltage at the wall outlet with a voltmeter. It must be 120 volts ac for 120V models and 230 volts ac for 230V models.
	2. Off/On/Start switch	(A) Momentarily press the Off/On/Start switch to the "START" (lower) position.  (B) Refer to <i>Service</i> - Off/On/Start switch for testing procedures. See page 11.
	3. Timer	Refer to <i>Service</i> - Timer for testing procedures. See page 17.
	4. Relay	Refer to <i>Service</i> - Relay for testing procedures. See page 14.
	5. Motor overload protector	Remove the cover plate located on the right side of the housing. Press the red "Reset" button. Listen carefully for a "click". This resets the motor protection circuit and indicates that an overload may have been encountered by the motor. (An overload can occur when something other than coffee is inserted into the hopper for grinding.) Refer to <i>Service</i> Motor for disassembly procedures. See page 12.
	6. Motor	Refer to <i>Service</i> - Motor for testing procedures. See page 12.
Grinder will not shut off.	1. Off/On/Start switch	(A) Place the switch in the "OFF/STOP" position.  (B) Refer to <i>Service</i> - Off/On/Start Switch for testing procedures. See page 11.
	2. Timer	Refer to <i>Service</i> - Timer for testing procedures. See page 17.
	3. Relay	Refer to <i>Service</i> - Relay for testing procedures. See page 14.



## TROUBLESHOOTING (cont.)

<b>Problem</b>	<b>Probable Cause</b>	<b>Remedy</b>
Grinder starts, but will not dispense from either hopper.	1. Hoppers	Begin each grind cycle by visually inspecting the hoppers for ample supplies of whole bean coffee.
	2. Bottoms of hoppers	Foreign materials must not block the openings at the bottom of the hoppers.
	3. Off/On/Start switch	Refer to <i>Service</i> - Off/On/Start switch for testing procedures. See page 11.
	4. Slide plates	(A) Check to see that the slide plates move freely to allow beans to travel into the grind chamber.
		(B) Refer to <i>Service</i> -Slide Plates for testing procedures. See page 15.
	5. Solenoids	Refer to <i>Service</i> - Solenoids for testing procedures. See page 16.
	6. Shear plate	Refer to <i>Service</i> - Grind Chamber for replacement procedures. See page 13.
7. Solenoid Limit Thermostat	Refer to <i>Service</i> - Solenoids for testing procedures. See page 16.	
Timer will not display or displays incorrectly.	1. Digital Timer	(A) Unplug the grinder. Wait a few seconds and plug it in again.
		(B) Refer to <i>Service</i> - Timer for testing procedures. See page 17.
Incorrect amount of coffee.	1. Timer adjustment	Refer to the <i>Adjustments</i> section. See page 6.
	2. Snubber	Refer to <i>Service</i> - Snubber for replacement procedures. See page 16.
Incorrect coffee grind dispensed.	1. Burr adjustment	Refer to the <i>Adjustments</i> section. See page 6.

## SERVICE

This section provides procedures for testing and replacing various major components used in this grinder should service become necessary. Refer to *Troubleshooting* for assistance in determining the cause of any problem.

**WARNING** - Inspection, testing, and repair of electrical equipment should be performed only by qualified service personnel. The grinder should be unplugged when servicing, except when electrical tests are required and the test procedure specifically states to plug-in the grinder.

### Component Access

**WARNING** - Unplug the grinder before the removal of any panel or the replacement of any component.

All components are accessible by the removal of the upper and lower front inspection panels, hopper assembly, and rear panel.

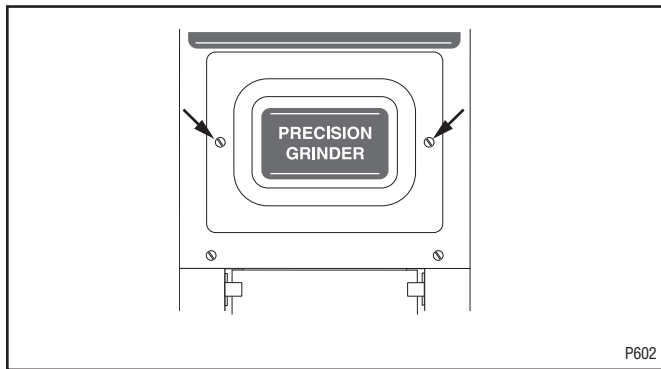

The upper front inspection panel is attached with two 6-32 slotted head screws.

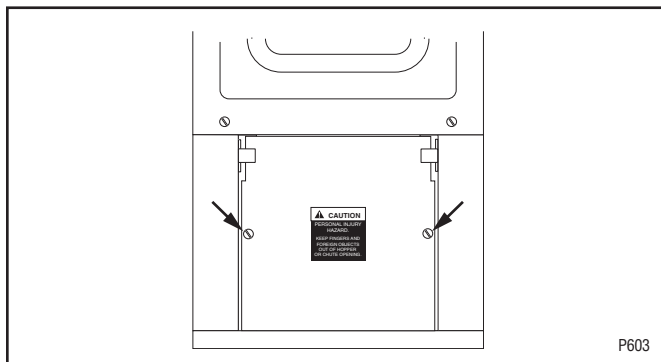

The lower front inspection panel is attached with two 6-32 slotted head screws.

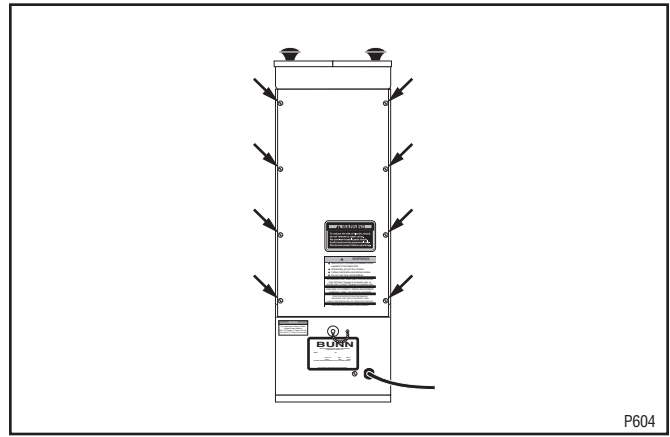

The rear panel is attached with eight 8-32 slotted head screws.

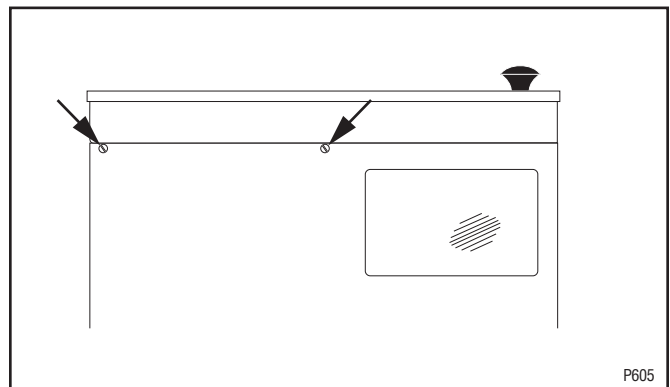

The hopper assembly is attached with four 6-32 slotted head screws with locking nuts located on the sides of the housing near the center and rear. Removal of the hopper will also require disconnection of the solenoid wires from the grinder wiring harness.

### Contents

Off/On/Start Switch .....	11
Motor .....	12
Relay .....	14
Slide Plates .....	15
Snubber .....	16
Solenoids .....	16
Timer .....	17
Hopper Selector Switch .....	20
Batch Selector Switch .....	21

## SERVICE (cont.)

### Off/On/Start Switch

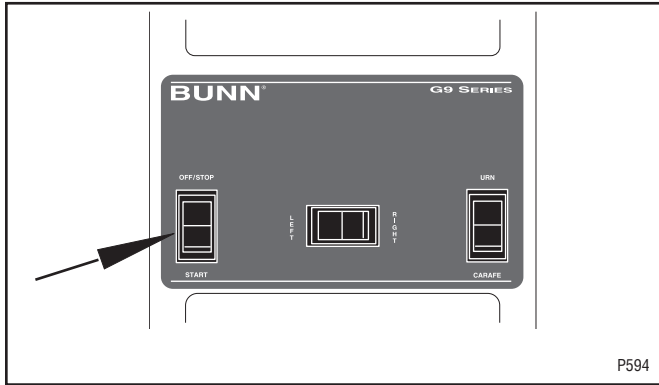

#### Location:

The Off/On/Start switch is located to the left side on the front of the housing above the upper front inspection panel.

#### Test Procedure:

1. Unplug the grinder.
2. Remove the black wire from the switch.
3. Check for continuity across the black wire from the Off/On/Start switch and the left blade of the cordset connector (see illustration below).

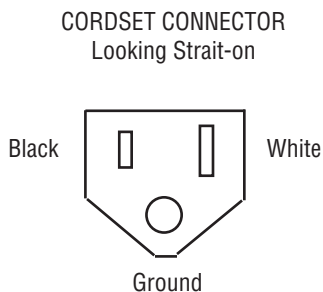

If continuity is present as described, proceed to #4.  
If continuity is not present as described, refer to the *Wiring Diagrams* and check the grinder wiring harness.

4. Remove the remaining wires from the switch.
5. Check for continuity across the left terminals when the switch is placed in both the “ON” (center) and “START” (lower) positions. Continuity must not be present in the “OFF” position.

If continuity is present as described, proceed to #6.  
If continuity is not present as described, replace the switch.

6. Check for continuity across the right terminals when the switch is placed in the “START” (lower) position only. Continuity must not be present in the “OFF” position.

If continuity is present as described, the Off/On/Start switch is operating properly.

If continuity is not present as described, replace the switch.

#### Removal and Replacement:

1. Remove all wires from the switch terminals.
2. Compress the clips inside the front wrapper and gently push the switch through the opening.
3. Push the new switch into the opening and spread the clips to retain the switch in the hood.
4. Refer to the following illustration when reconnecting the wires.

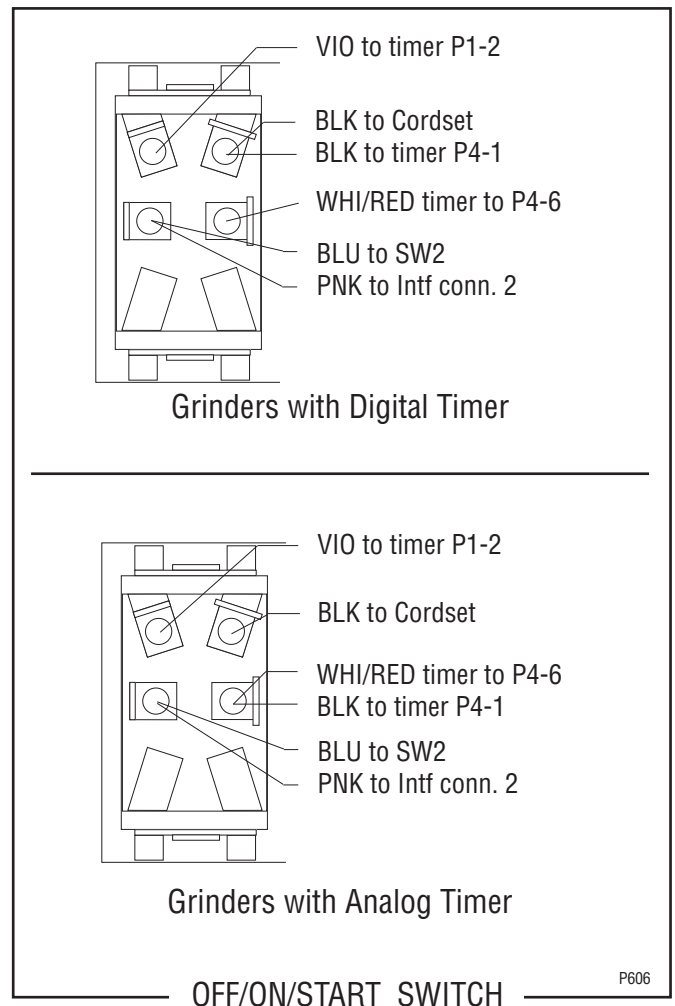

## SERVICE (cont.)

### Motor

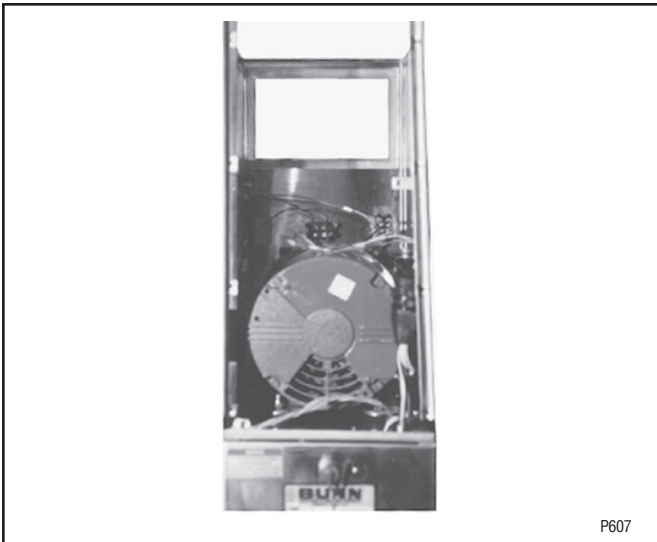

#### Location:

The motor is located in the upper wrapper.

#### Test Procedure:

1. Remove the cover plate located on the right side of the housing. Press the red “Reset” button visible through the opening. Listen carefully for a “click”. This resets the motor protection circuit and may indicate that something other than coffee was inserted into the hopper for grinding.

If the grinder remains unable to start, proceed to #2. If the grinder stops operating shortly after starting, refer to the removal and replacement steps to gain access to the grind chamber. Remove any foreign materials that may be found.

2. Unplug the grinder.
3. Remove the electrical access panel at the rear of the motor.
4. Connect a voltmeter across terminals L1 & L2 of the motor. Plug-in the grinder. Momentarily press the Off/On/Start switch to the “START” (lower) position and release. The indication must be 120 volts ac for 120V models and 230 volts ac for 230V models.
5. Unplug the grinder

If voltage is present as described and the grinder remains unable to start, replace the motor.

If voltage is not present as described, refer to the *Wiring Diagrams*, and check the grinder wiring harness.

#### Removal and Replacement - MOTOR

1. Remove all wires from the solenoids and lift the hopper assy out of the grinder housing.
2. Remove all wires from all switches, motor, and motor mounting plate.
3. The entire wiring harness must be fed into the bottom of the grinder housing through the hole in the motor mounting plate.
4. Remove both 6-32 screws beneath the upper front inspection panel.
5. Remove the six 10-32, slotted, hex head screws on top of the motor mounting plate.
6. Slowly slide the assembly out the rear of the grinder housing. The mounting plate may have to be raised to gain clearance for the motor hardware and wiring harness bushing.
7. Remove the four 5/16”-18 bolts and nuts to separate the motor from the mounting plate.
8. Mount the new motor and tighten the four bolts and nuts. They should be tightened approximately one full turn past snug.
9. Slide the motor mounting plate into the rear of the grinder housing.
10. Feed the wiring harness into the top of the housing through the hole in the motor plate.
11. Reinstall the six 10-32 hex head screws through the motor plate and the two 6-32 slotted head screws through the housing.
12. Reattach the green wire to the 10-32 stud on the motor mounting plate.
13. Refer to the *Off/On/Start Switch, Hopper Selector Switch and Batch Selector Switch* sections when reconnecting the switch wires.
14. Refer to the *Solenoid* section when reconnecting the solenoid wires.
15. Refer to the following illustration when reconnecting the wires.

## SERVICE (cont.)

### Motor (cont.)

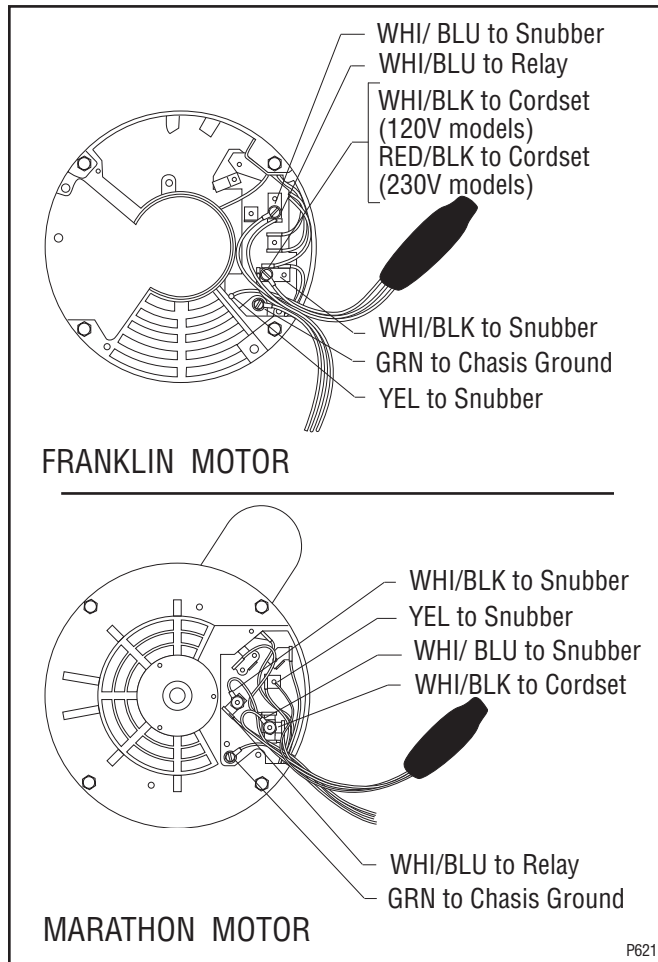

### Removal and Replacement - GRIND CHAMBER

1. Remove the two 1/4"-20 screws holding the front cover to the burr housing. Carefully remove the burr housing front cover. Inspect the adjusting screw to see if the thrust plug is worn.  
**Replace if excessively worn or damaged.**
2. Carefully remove the rotor cup, shear plate, and burr rotor from the grinder. Inspect the shear plate and burrs for wear.  
**Replace if excessively worn or damaged.**
3. Remove and inspect the stationary burr for wear.  
**Replace if excessively worn or damaged.**
4. Inspect the grind chamber and remove any foreign materials. The burrs will not properly seat in the chamber if any material or coffee particles remain.
5. Reinstall the stationary burr, burr rotor, shear plate, rotor cup, and dial plate to the burr housing.
6. Refer to the *Adjustments* section to vary the grind dispensed.

## SERVICE (cont.)

### Relay

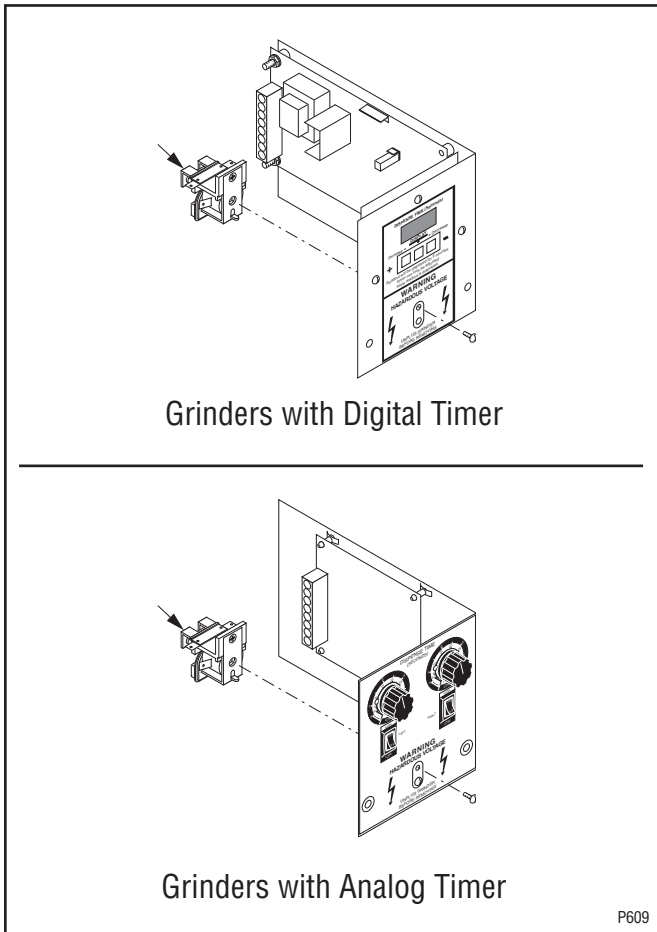

#### Location:

The relay is located on the timer bracket in the grinder base. The bracket can be removed by loosening the two 8-32 slotted head screws beneath the timer dial.

#### Test Procedure:

1. Unplug the grinder.
2. Connect a voltmeter across the red/black and white/green wires of the relay coil. Plug-in the grinder. Momentarily press the Off/On/Start switch to "START" (lower) position and release. The indication must be 120 volts ac for 120V models and 230 volts ac for 230V models for the approximate setting on the timer.
3. Unplug the grinder.

If voltage is present as described, reconnect the red/black and white/green wires to the relay coil, and proceed to #4.

If voltage is not present as described, refer to the *Wiring Diagrams* and check the grinder wiring harness.

4. Remove the white/red and white/blue wires from the relay contacts.
5. Check for continuity across the relay contacts when the Off/On/Start switch is pressed to the "START" (lower) position and released. Plug-in the grinder. Continuity must be present for the approximate setting on the timer.
6. Unplug the grinder.

If continuity is present as described, reconnect the white/red and white/blue wires, the relay is operating properly.

If continuity is not present as described, replace the relay.

#### Removal and Replacement

1. Remove all wires from the relay terminals.
2. Remove the 6-32 screw fastening the relay to the timer bracket.
3. Mount the new relay to the timer bracket and tighten the screw.
4. Refer to the following illustration when reconnecting the wires.

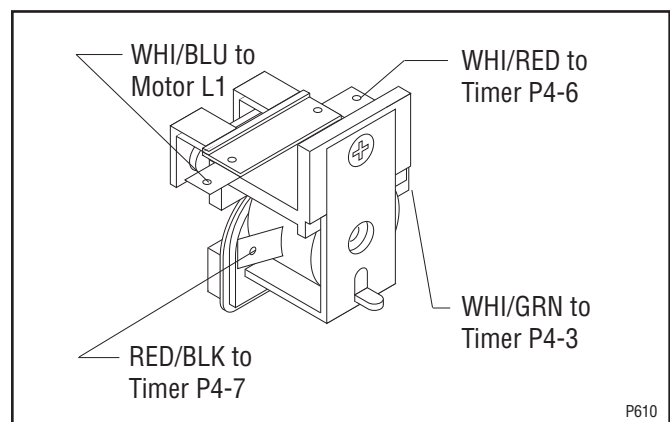

## SERVICE (cont.)

### Slide Plates

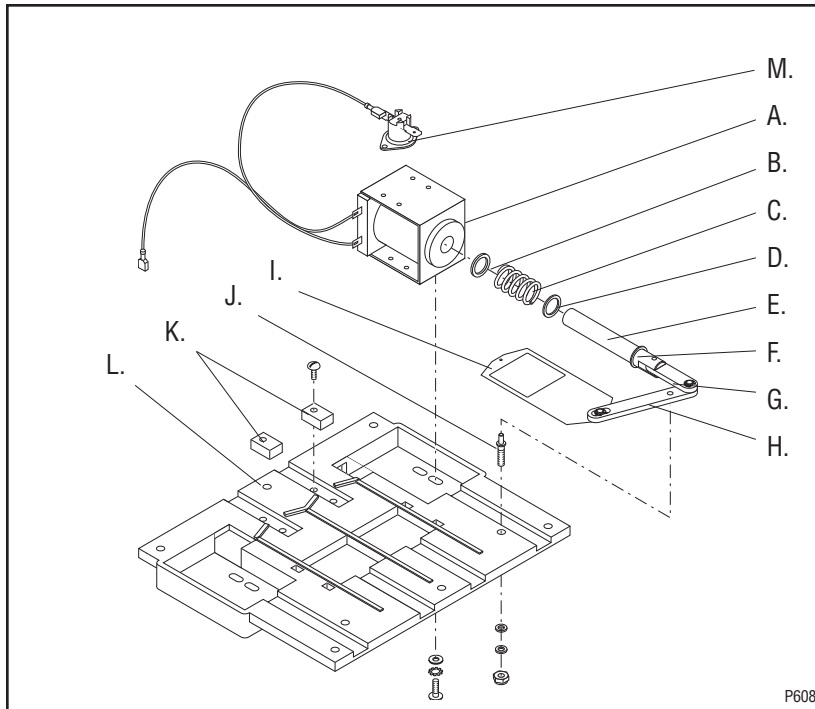

- A. Solenoid Coil
- B. Fiber Washer
- C. Spring
- D. Spring Retaining Washer
- E. Solenoid Plunger
- F. Snap Ring
- G. Short Link
- H. Long Link
- I. Slide Plate
- J. Pivot Pin
- K. Stop Block
- L. Solenoid Mounting Plate
- M. Solenoid Limit Thermostat

#### Location:

The slide plates are located on the solenoid mounting plate immediately beneath the hopper openings.

**The slide plates must always remain flat for proper operation.**

#### Test Procedure:

With the solenoid mounting plate attached to the hopper, push the solenoid plunger into the coil. The slide plate must move freely in the assembly and snap closed when the plunger is released. Repeat for the other slide plate.

If the slide plates move as described, they are operating correctly.

If the slide plates do not move as described, the problem may be in any one or more of the linkage pieces, springs, slide plates, and/or the solenoid mounting plate. Disassemble the solenoid mounting plate assembly and inspect all components for free movement.

**Replace if excessively worn or damaged.**

#### Removal and Replacement:

1. Remove the hopper from the grinder.
2. Remove six slotted head screws holding the solenoid mounting panel to the hopper.
3. The slide plate with attached linkage can be lifted off the pivot pin and removed with the solenoid plunger.
4. Refer to the illustration above when reassembling the components.
5. **Inspect the slide plates after reassembly. They must move freely.**

## SERVICE (cont.)

### Snubber

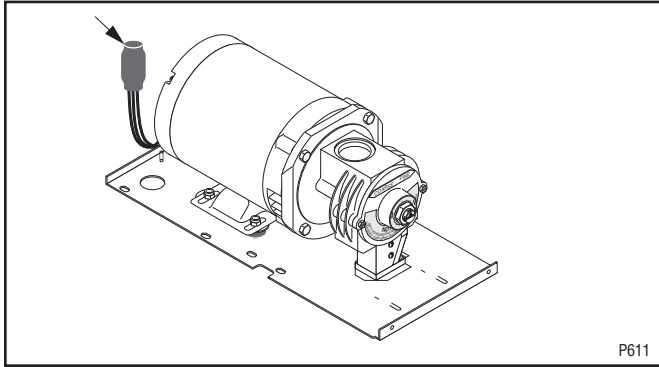

#### Location:

The snubber is located at the back of the motor attached to the right side of the wiring harness.

#### Removal and Replacement:

1. Remove snubber wires from the motor terminals.
2. Cut the ties holding snubber to the wiring harness.
3. Refer to the following illustration when reconnecting the wires.
4. Fasten snubber to the wiring harness using new ties.

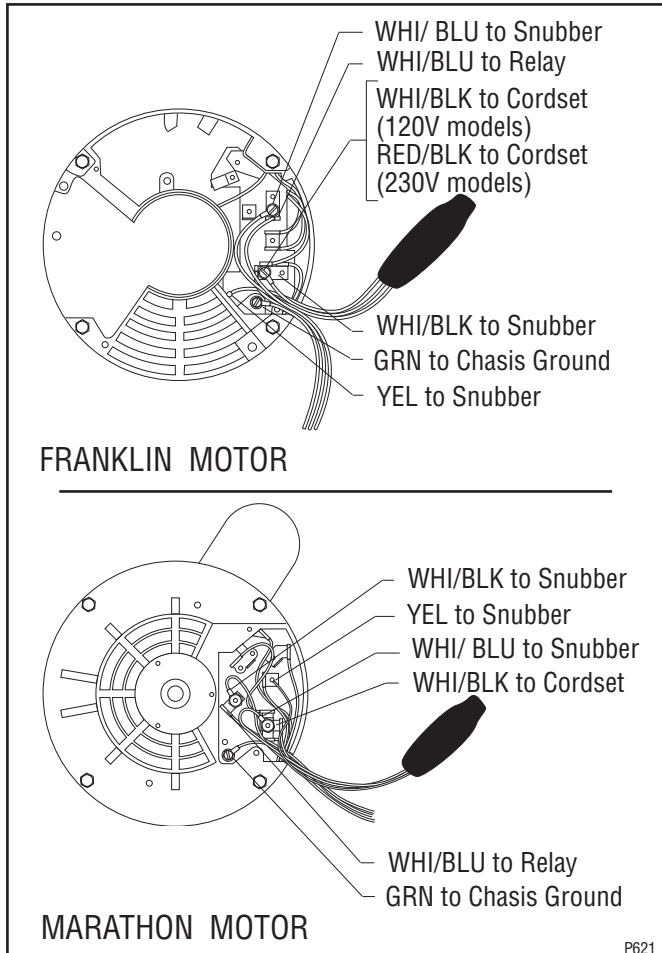

## Solenoids

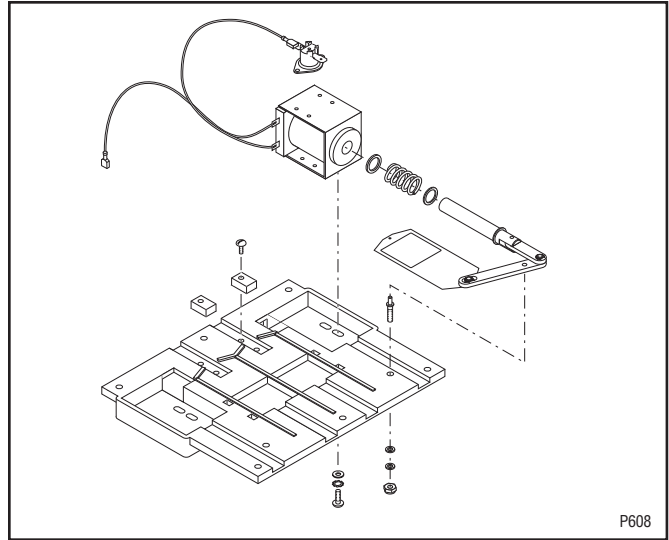

#### Location:

The solenoids are located on the mounting plate immediately beneath the hoppers.

#### Test Procedure:

1. Unplug the grinder.
2. Connect a voltmeter across the left or right solenoid coil terminals. Plug-in the grinder. Momentarily press the Off/On/Start switch to "START" (lower) position and release (hopper selector switch must be corresponding to the suspect solenoid). The indication must be 120 volts ac for 120V models and 230 volts ac for 230V models.
3. Unplug the grinder.

If voltage is present as described, proceed to #4. If voltage is not present as described, refer to the *Wiring Diagram* and check the grinder wiring harness.

4. Separate the connectors on the white/brown wires of the solenoids from the connectors on the grinder wiring harness (RED/BLK) and the limit thermostat.
5. Check for continuity across the white/brown wires on the suspect solenoid coil.



## SERVICE (cont.)

### Solenoid(s) (cont.)

If continuity is present as described, reconnect the white/brown wires to the grinder wiring harness, and proceed to #6.

If continuity is not present as described, replace the solenoid.

6. Check for continuity across the terminals of the limit thermostat.

If continuity is present as described, reconnect the wires, and proceed to #7.

If continuity is not present as described, replace the limit thermostat.

7. Check the solenoid for coil action when the control switch is momentarily pressed to the "START" (lower) position and released. Plug-in the grinder. Listen carefully in the vicinity of the solenoid for a "clicking" sound as the coil magnet attracts and after a period of time, repels the plunger.
8. Unplug the grinder.

If the sound is heard as described and the plunger remains unable to move or move freely, refer to the slide plate section.

If the sound is not heard as described, replace the solenoid.

#### Removal and Replacement:

1. Remove the hopper assy from the grinder.
2. Remove the four 8-32 slotted-head screws holding the solenoid coil to the solenoid panel.
3. Feed the white/brown wires through the hole in the solenoid mounting plate and loosely install the new solenoid coil.
4. Look through the collector on the bottom of the assy and adjust the slide plate travel distance when installing the solenoid coil.
5. Push the solenoid plunger into the solenoid coil with your hand while moving the coil forward or backward in its mounting holes.
6. Securely tighten the mounting screws when the slide plate appears to have no metal showing in the front or back of the hopper hole.
7. Refer to the following illustration when reconnecting the wires.

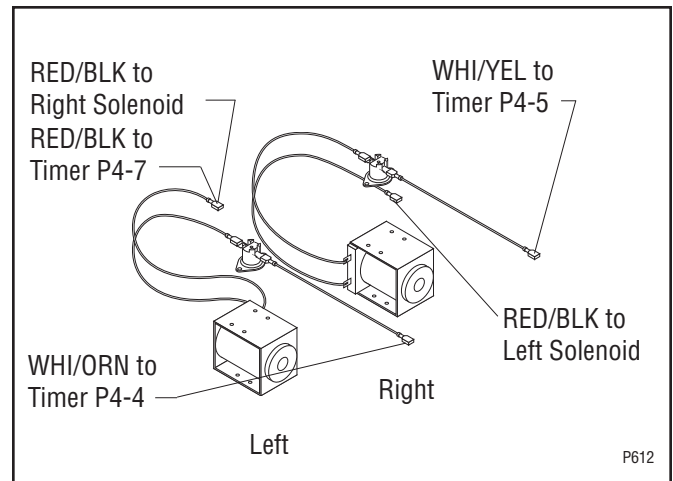

### Timer

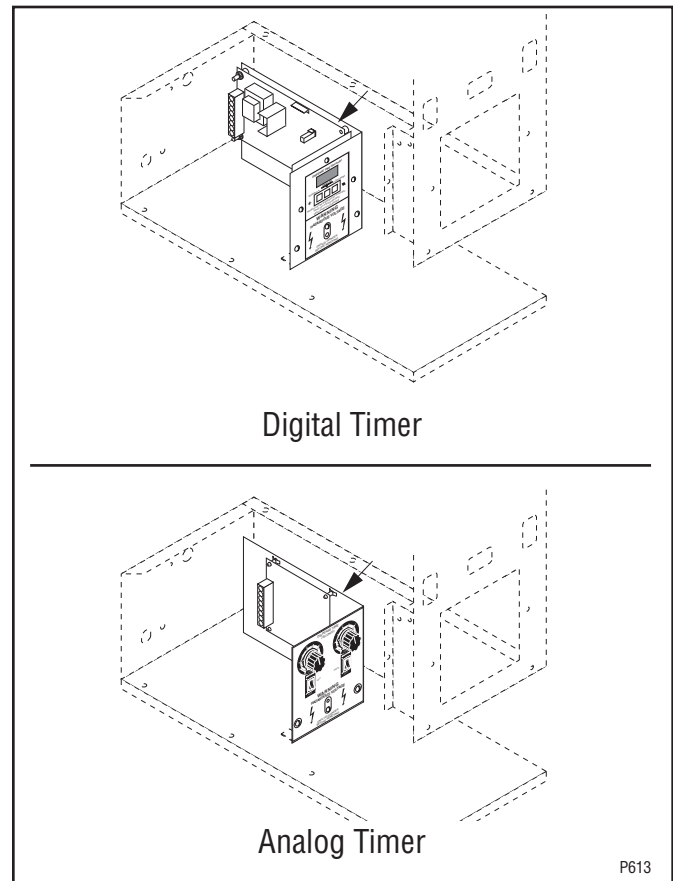

#### Location:

The timer is located in the grinder base.

#### Test Procedure:

1. Unplug the grinder.
2. Connect a voltmeter across contacts 1 & 2 of the larger connector (P4) on the timer board. Plug-in the grinder. The indication must be 120 volts ac for 120V models and 230 volts ac for 230V models.
3. Unplug the grinder.

## SERVICE (cont.)

### Timer (cont.)

4. Connect a voltmeter across contacts 2 & 6 of the larger connector (P4) on the timer board. Plug-in the grinder. When the control switch is in any position except "OFF" (center), the indication must be 120 volts ac for 120V models and 230 volts ac for 230V models.
5. Unplug the grinder.

If voltage is present as described, proceed to #6.

If voltage is not present as described, refer to the *Wiring Diagram* and check the grinder wiring harness.

6. Connect a voltmeter across contacts 3 & 7 of the larger connector (P4) on the timer board. Plug-in the grinder. Momentarily press the Off/On/Start switch to "START" (lower) position and release. The indication must be 120 volts ac for 120V models and 230 volts ac for 230V models.
7. Unplug the grinder.

If voltage is present as described, proceed to #8.

If voltage is not present as described, replace the timer.

8. Connect a voltmeter across contacts 4 & 7 of the larger connector (P4) on the timer board. Plug-in the grinder. Place the hopper selector switch to the left position. Momentarily press the Off/On/Start switch to the "START" (lower) position and release. The indication must be 120 volts ac for 120V models and 230 volts ac for 230V models and should remain for the approximate timer setting.
9. Unplug the grinder.

If voltage is present as described, proceed to #10.

If voltage is not present as described, replace the timer.

10. Connect a voltmeter across contacts 5 & 7 of the larger connector (P4) on the timer board. Plug-in the grinder. Place the hopper selector switch to the right position. Momentarily press the Off/On/Start switch to the "START" (lower) position and release. The indication must be 120 volts ac for 120V models and 230 volts ac for 230V models and should remain for the approximate timer setting.

11. Unplug the grinder.

If voltage is present as described, the timer is operating properly.

If voltage is not present as described, replace the timer.

### Removal and Replacement:

1. Separate the grinder wiring harness connectors from the timer circuit board.
2. Remove the relay from the timer bracket.
3. Attach the relay to the new timer bracket.
4. Refer to the following illustration when reattaching the connectors.
5. Refer to the *Adjustments* section to reset the volume dispensed.

# SERVICE (cont.)

## Timer (cont.)

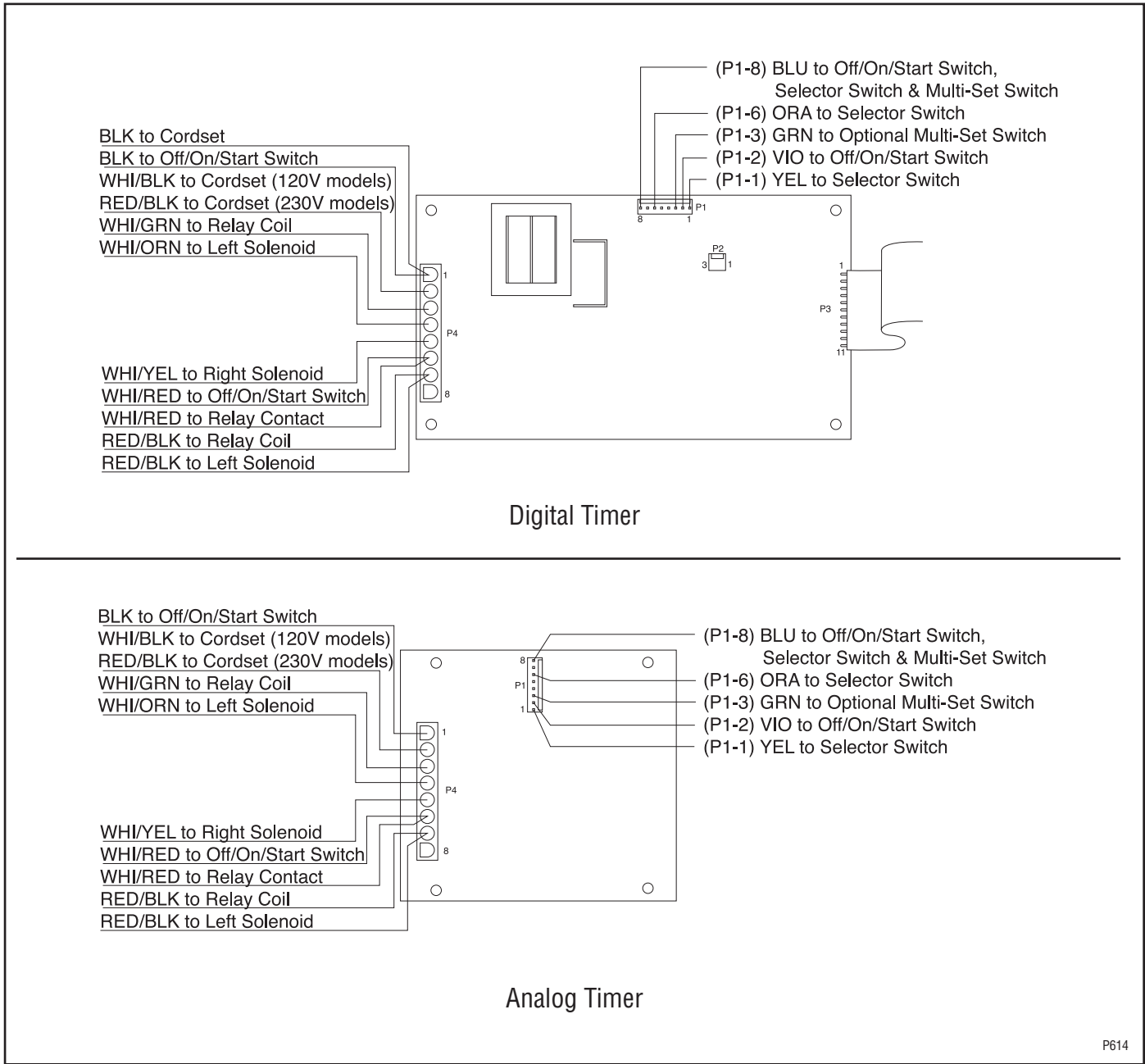

## SERVICE (cont.)

### Hopper Selector Switch

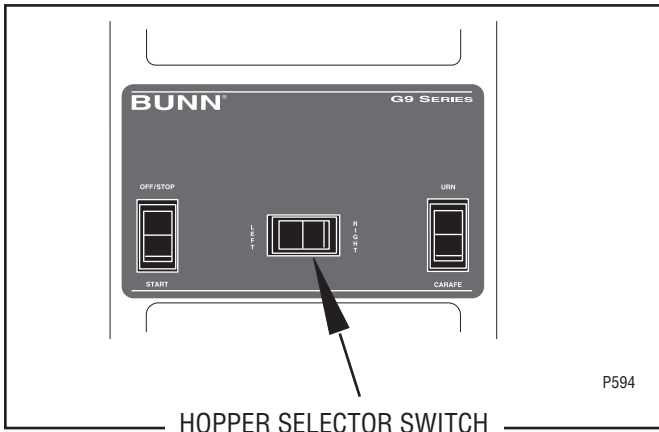

#### Location:

The hopper selector switch is located in the center on the front of the hopper housing.

#### Test Procedure:

1. Disconnect the grinder from the power source.
2. Remove all wires from the switch terminals.
3. Place the selector switch in the left position.
4. Check for continuity across the center and right terminals on the rear of the switch.
5. Continuity must not be present across the center and left terminals on the rear of the switch.
6. Check the bottom row, then the top row of terminals.

If continuity is present as described proceed to #7.  
If Continuity is not present as described replace the switch.

7. Place the selector switch in the right position.
8. Check for continuity across the center and left terminals on the rear of the switch.
9. Continuity must not be present across the center and right terminals on the rear of the switch.
10. Check the bottom row, then the top row.

If continuity is present as described, reconnect the wires, the switch is operating properly.  
If continuity is not present as described, replace the switch.

#### Removal and Replacement:

1. Remove all wires from the switch terminals.
2. Compress the clips inside the front of the housing and gently push the switch through the opening.
3. Push the new switch into the opening and spread the clips to retain the switch in the housing.
4. Refer to Fig. below when reconnecting the wires.

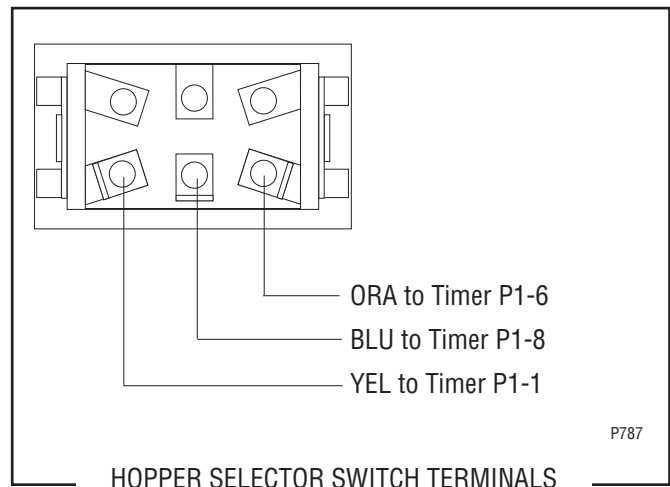

## SERVICE (cont.)

### Batch Selector Switch (Models w/Multi-Set option)

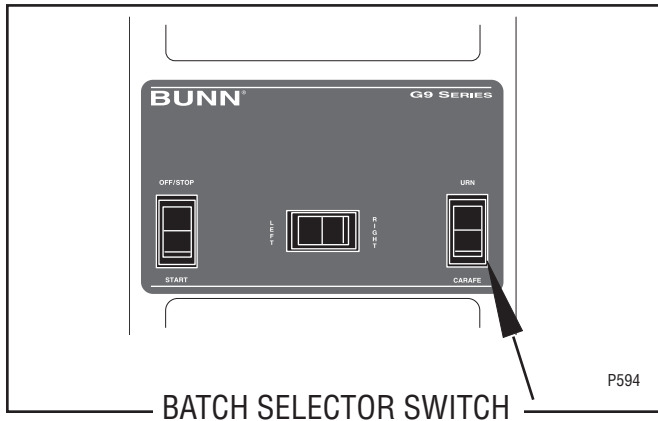

#### Location:

The Batch Selector Switch is located in the lower right front of the hopper housing.

#### Test Procedure:

1. Disconnect grinder from the power supply.
2. Remove all wires from the switch terminals.
3. Check that the switch is installed properly.
4. Place the selector switch in the left position.
5. Check for continuity across the terminals on the rear of the switch.

If continuity is present as described proceed to #6.  
If continuity is not present as described, replace the switch.

6. Place the selector switch in the right position.
7. Check for continuity across the terminals on the rear of the switch. Continuity should not be present across terminals in the right position.

If continuity is not present as described, reconnect the wires, the switch is operating properly.  
If continuity is present replace the switch.

#### Removal and Replacement:

1. Remove all wires from the switch terminals.
2. Compress the clips inside the front of the housing and gently push the switch through the opening.
3. Push the new switch into the opening and spread the clips to retain the switch in the housing.
4. Refer to Fig. below when reconnecting the wires.

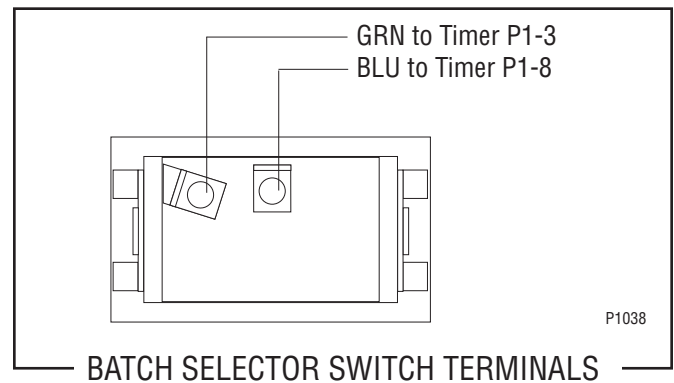

# WIRING DIAGRAM

## SCHEMATIC WIRING DIAGRAM G9-2 HD (DIGITAL TIMER)

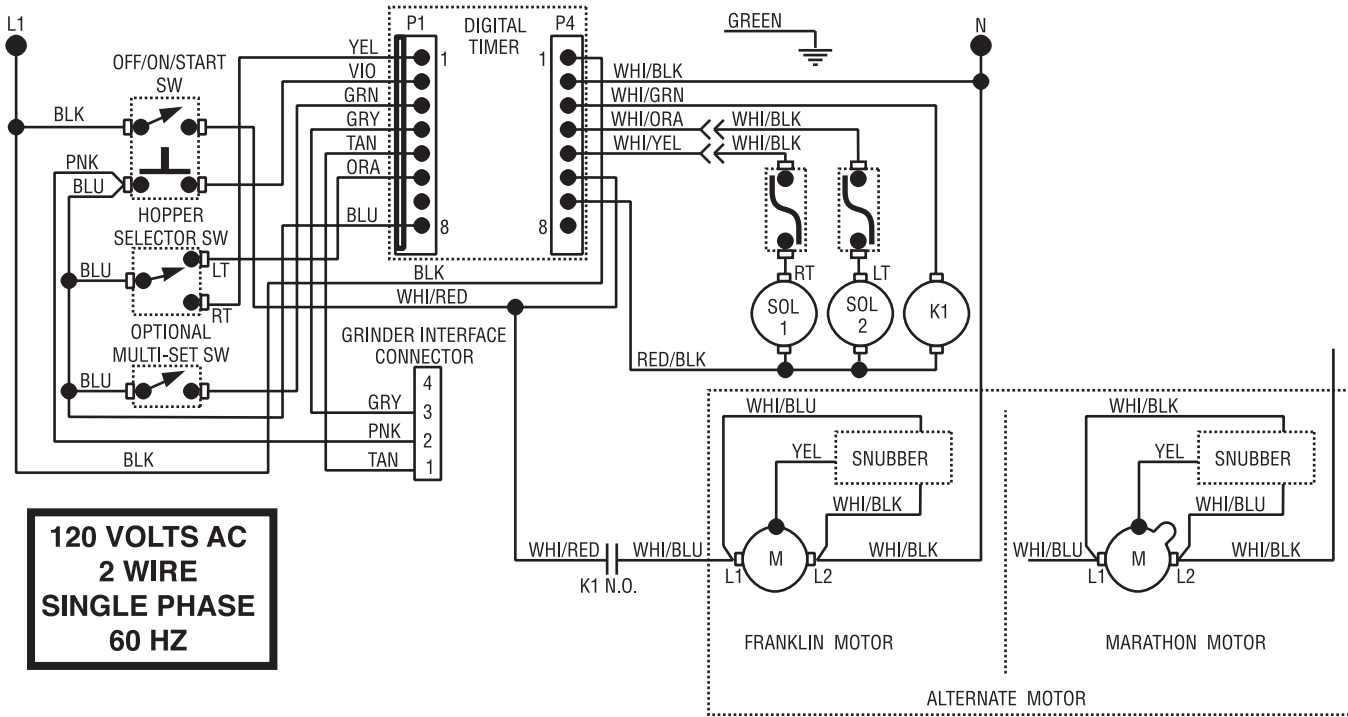

## SCHEMATIC WIRING DIAGRAM G9-2 HD (ANALOG TIMER)

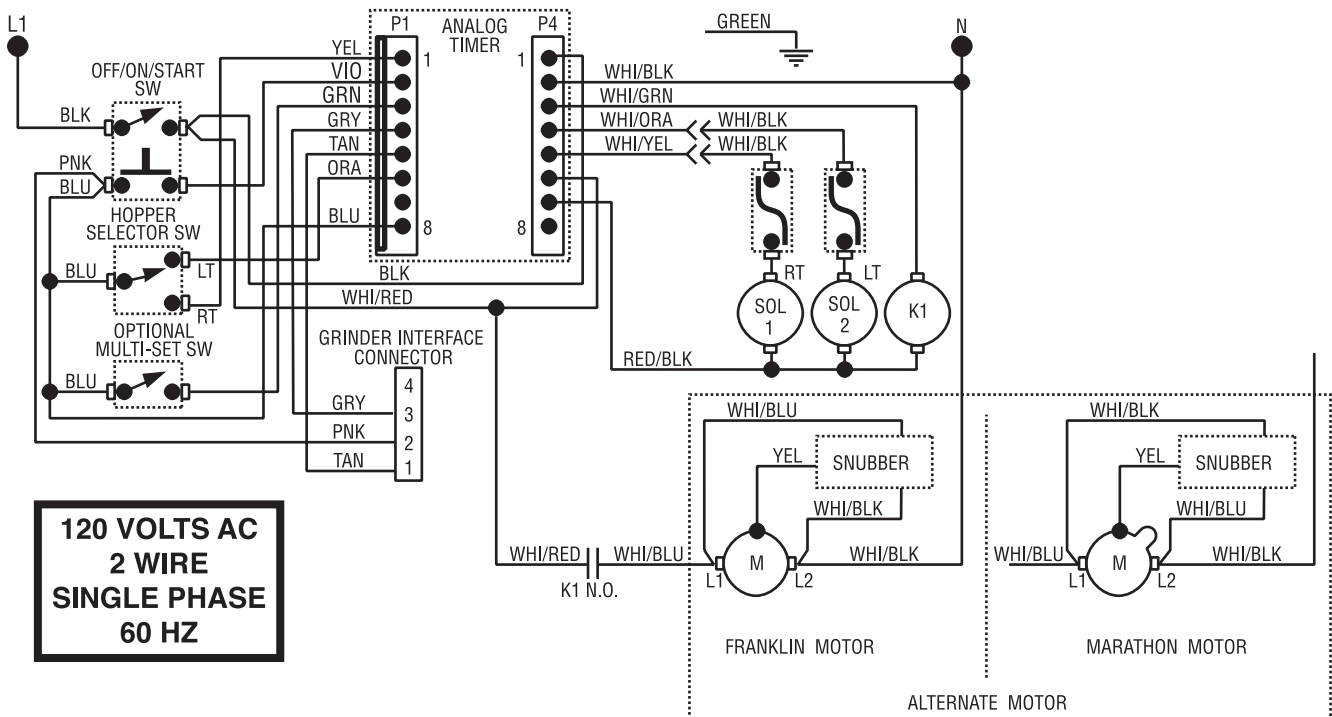

# SCHEMATIC WIRING DIAGRAM G9-2A HD

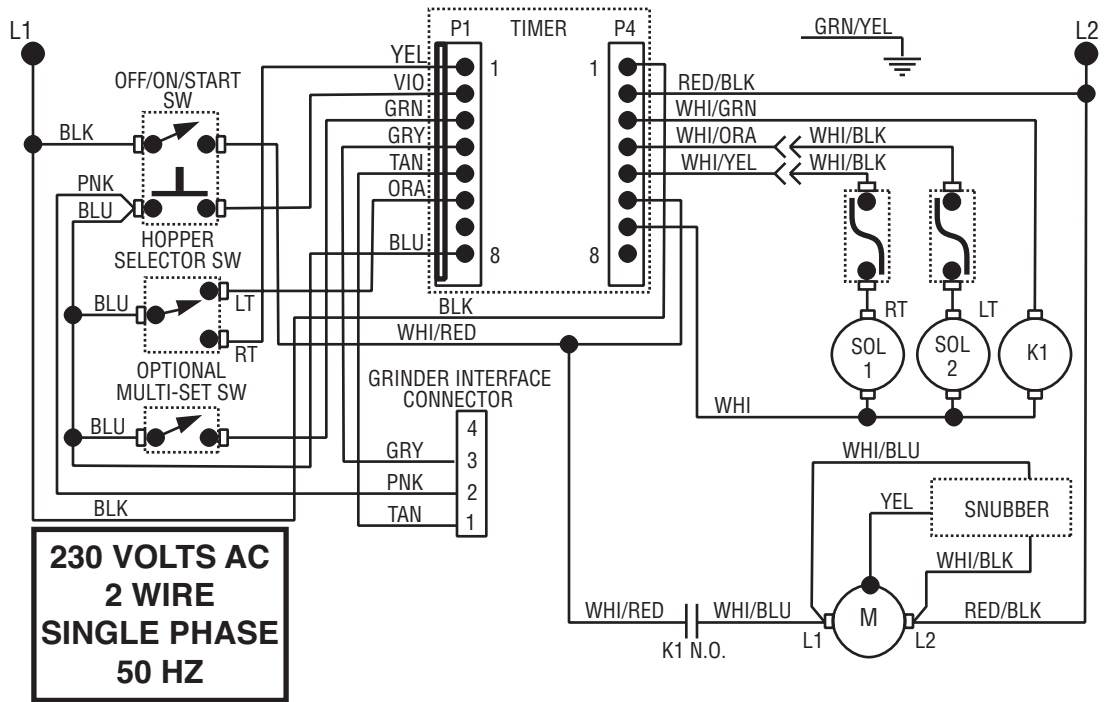

# SCHEMATIC WIRING DIAGRAM G9-2 HD (DIGITAL TIMER W/BATCH SELECTOR)

