

BUNN®

***G9-2 HD
G9-2T HD
G9-2 HD-S***

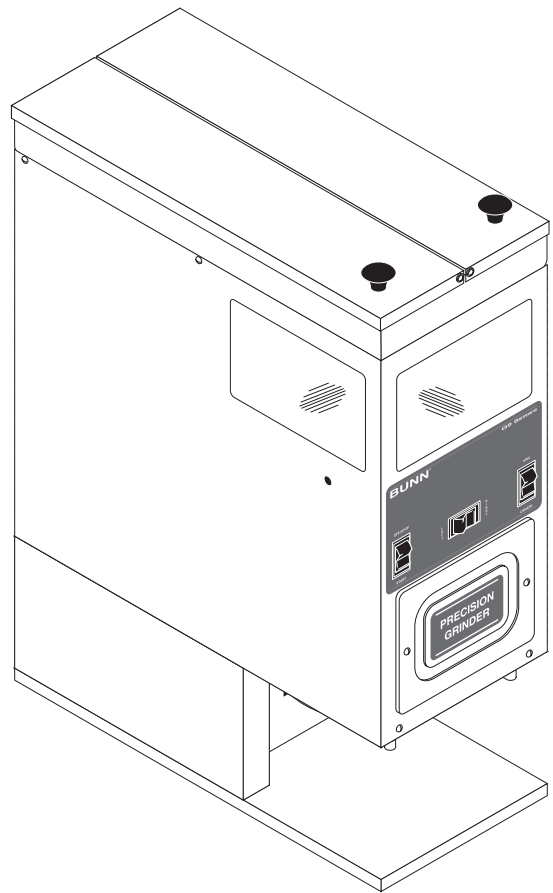
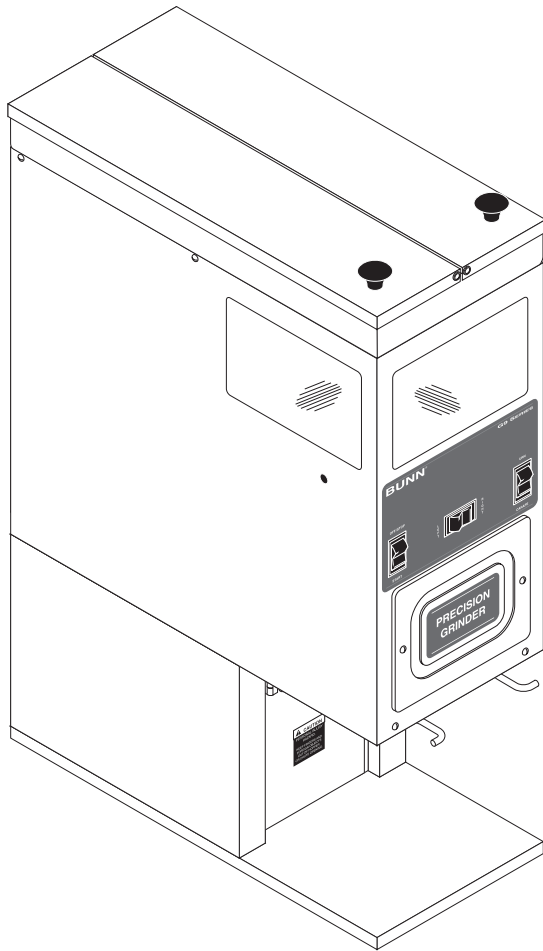

ILLUSTRATED PARTS CATALOG

Designs, materials, weights, specifications, and dimensions for equipment or replacement parts are subject to change without notice.

BUNN-O-MATIC CORPORATION

POST OFFICE BOX 3227

SPRINGFIELD, ILLINOIS 62708-3227

PHONE: (217) 529-6601 FAX: (217) 529-6644

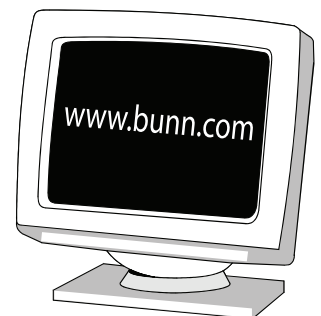

BUNN-O-MATIC COMMERCIAL PRODUCT WARRANTY

Bunn-O-Matic Corp. (“BUNN”) warrants equipment manufactured by it as follows:

- 1) All equipment other than as specified below: 2 years parts and 1 year labor.
- 2) Electronic circuit and/or control boards: parts and labor for 3 years.
- 3) Compressors on refrigeration equipment: 5 years parts and 1 year labor.
- 4) Grinding burrs on coffee grinding equipment to grind coffee to meet original factory screen sieve analysis: parts and labor for 3 years or 30,000 pounds of coffee, whichever comes first.

These warranty periods run from the date of installation BUNN warrants that the equipment manufactured by it will be commercially free of defects in material and workmanship existing at the time of manufacture and appearing within the applicable warranty period. This warranty does not apply to any equipment, component or part that was not manufactured by BUNN or that, in BUNN’s judgment, has been affected by misuse, neglect, alteration, improper installation or operation, improper maintenance or repair, damage or casualty. This warranty is conditioned on the Buyer 1) giving BUNN prompt notice of any claim to be made under this warranty by telephone at (217) 529-6601 or by writing to Post Office Box 3227, Springfield, Illinois 62708-3227; 2) if requested by BUNN, shipping the defective equipment prepaid to an authorized BUNN service location; and 3) receiving prior authorization from BUNN that the defective equipment is under warranty.

THE FOREGOING WARRANTY IS EXCLUSIVE AND IS IN LIEU OF ANY OTHER WARRANTY, WRITTEN OR ORAL, EXPRESS OR IMPLIED, INCLUDING, BUT NOT LIMITED TO, ANY IMPLIED WARRANTY OF EITHER MERCHANTABILITY OR FITNESS FOR A PARTICULAR PURPOSE. The agents, dealers or employees of BUNN are not authorized to make modifications to this warranty or to make additional warranties that are binding on BUNN. Accordingly, statements by such individuals, whether oral or written, do not constitute warranties and should not be relied upon.

If BUNN determines in its sole discretion that the equipment does not conform to the warranty, BUNN, at its exclusive option while the equipment is under warranty, shall either 1) provide at no charge replacement parts and/or labor (during the applicable parts and labor warranty periods specified above) to repair the defective components, provided that this repair is done by a BUNN Authorized Service Representative; or 2) shall replace the equipment or refund the purchase price for the equipment.

THE BUYER’S REMEDY AGAINST BUNN FOR THE BREACH OF ANY OBLIGATION ARISING OUT OF THE SALE OF THIS EQUIPMENT, WHETHER DERIVED FROM WARRANTY OR OTHERWISE, SHALL BE LIMITED, AT BUNN’S SOLE OPTION AS SPECIFIED HEREIN, TO REPAIR, REPLACEMENT OR REFUND.

In no event shall BUNN be liable for any other damage or loss, including, but not limited to, lost profits, lost sales, loss of use of equipment, claims of Buyer’s customers, cost of capital, cost of down time, cost of substitute equipment, facilities or services, or any other special, incidental or consequential damages.

392, AutoPOD, AXIOM, BrewLOGIC, BrewMETER, Brew Better Not Bitter, BrewWISE, BrewWIZARD, BUNN Espresso, BUNN Family Gourmet, BUNN Gourmet, BUNN Pour-O-Matic, BUNN, BUNN with the stylized red line, BUNNlink, Bunn-O-Matic, Bunn-O-Matic, BUNNserve, BUNNSERVE with the stylized wrench design, Cool Froth, DBC, Dr. Brew stylized Dr. design, Dual, Easy Pour, EasyClear, EasyGard, FlavorGard, Gourmet Ice, Gourmet Juice, High Intensity, iMIX, Infusion Series, Intellisteam, My Café, PowerLogic, Quality Beverage Equipment Worldwide, Respect Earth, Respect Earth with the stylized leaf and coffee cherry design, Safety-Fresh, savemycoffee.com, Scale-Pro, Silver Series, Single, Smart Funnel, Smart Hopper, SmartWAVE, Soft Heat, SplashGard, The Mark of Quality in Beverage Equipment Worldwide, ThermoFresh, A Partner You Can Count On, Air Brew, Air Infusion, Beverage Bar Creator, Beverage Profit Calculator, Brew better, not bitter., BUNNSource, Coffee At Its Best, Cyclonic Heating System, Digital Brewer Control, Nothing Brews Like a BUNN, Pouring Profits, Signature Series, Tea At Its Best, Phase Brew, The Horizontal Red Line, Titan, trifecta, Ultra, Velocity Brew are either trademarks or registered trademarks of Bunn-O-Matic Corporation.

TABLE OF CONTENTS

Electrical Controls 14

Hopper, Lid and Slide Plate Assy..... 8

Housing, Base and Panels..... 4

Motor, Burr Housing and Mounting Plate..... 12

Numerical Index..... 18

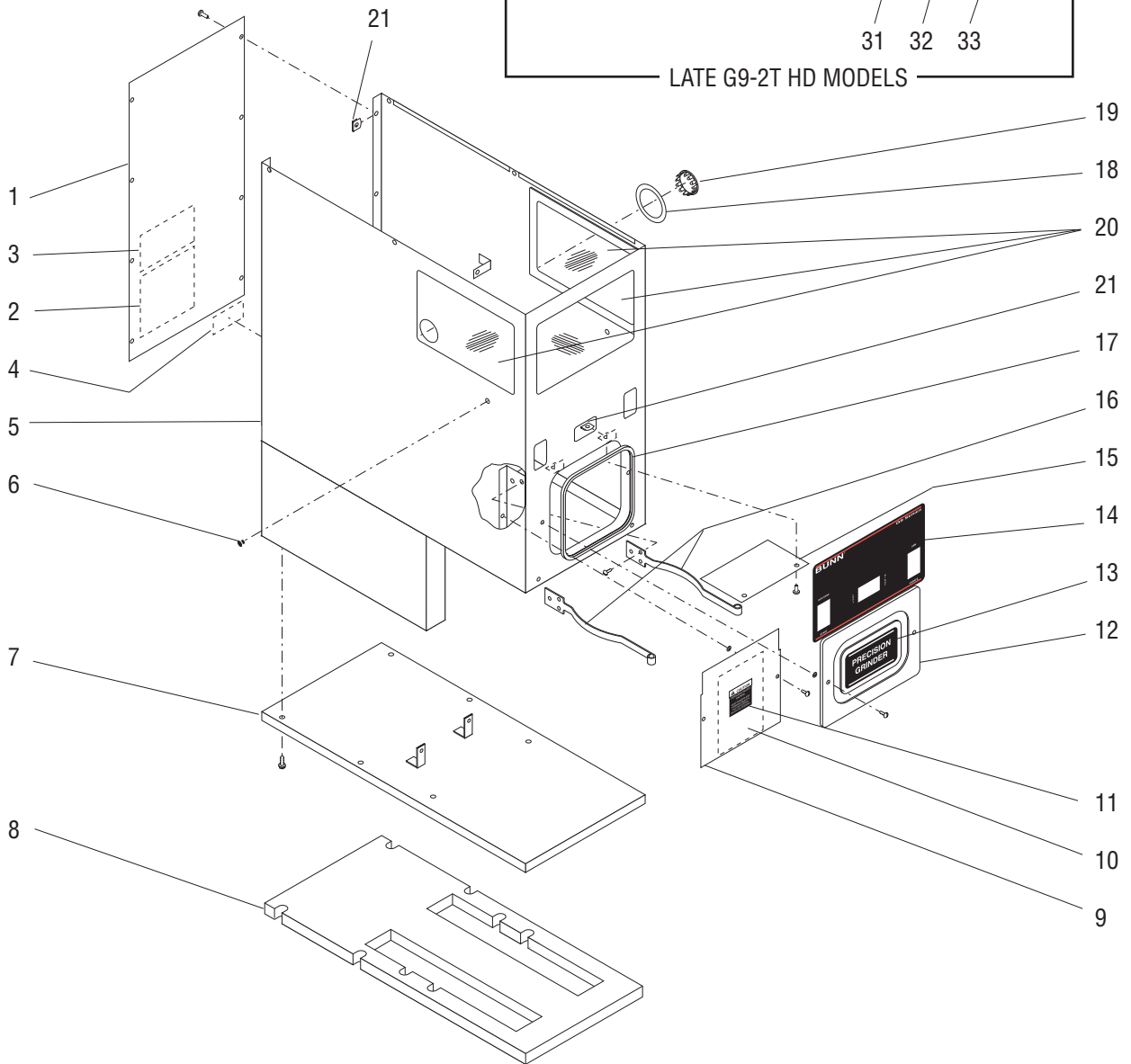
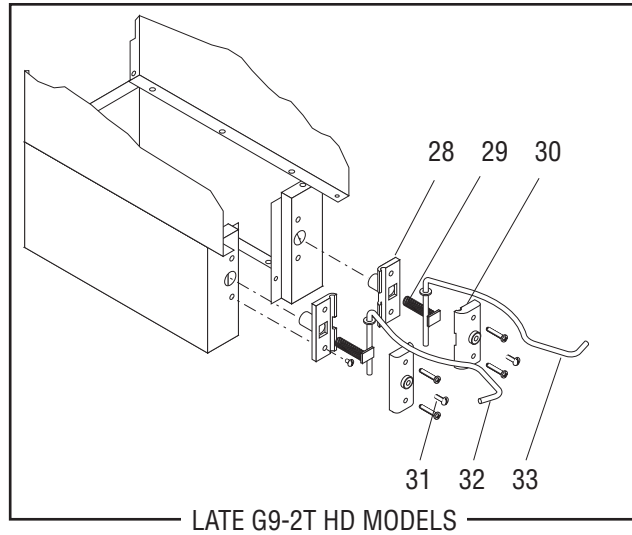
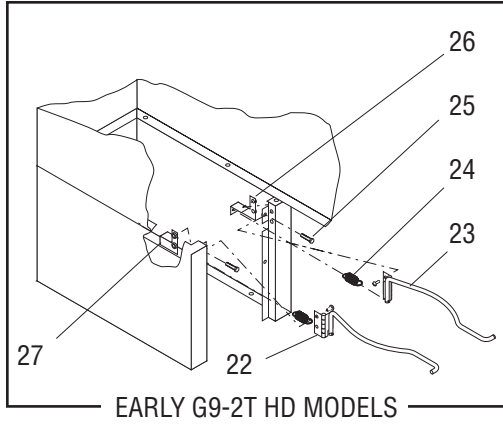

HOUSING, BASE AND PANELS

ITEM	PART NO.	QTY.	DESCRIPTION	
1	05844.1000	1	Rear Panel W/Decal (Includes items 2 & 3)	
	01315.0000	8	Screw, Truss Head #8-32 x .38"	
	01311.0003	8	Screw, Truss Head Blk #8-32 x .38"	
2	20545.0000	1	Decal, Warning Electrical	
3	37881.0000	1	Decal, No Serviceable Parts	
4	24237.0000	1	Decal, Notice - Interface Voltage	
5	25407.0000	1	Housing Assy W/Decals (G9-2 HD 120V)	Includes items 4, 18 & 20 Also order item 14
	25407.0004	1	Housing Assy W/Decals (BLK) (G9-2 HD 120V)	
	25407.0003	1	Housing Assy W/Decals (G9-2 HD 230V)	
	25408.0000	1	Housing Assy W/Decals SST (G9-2T HD 120V)	
	25408.0002	1	Housing Assy W/Decals (G9-2T HD 230V)	
25408.0003	1	Housing Assy W/Decals Blk (G9-2T HD 120V)		
6	05921.0000	1	Plug, Hole .25" Dia.	
7	05809.0000	1	Base (G9-2 HD & G9-2 HD-S)	
	05809.0002	1	Base (G9-2 HD) (BLK)	
	05752.0000	1	Base (G9-2T HD)	
	02311.0000	6	Screw, Hex Crimptite #10-32 x .50"	
8	05816.0000	1	Pad, Base	
9	20798.1003	1	Panel Assy W/Decals (120V) (G9-2 HD)	Includes screws and washers below and items 10 & 11
	20798.1014	1	Panel Assy W/Decals (BLK) (120V) (G9-2 HD)	
	20798.1004	1	Panel Assy W/Decals SST (120V) (G9-2T HD W/O or 2 batch sel.)	
	20798.1012	1	Panel Assy W/Decals Blk (120V) (G9-2T HD W/O or 2 batch sel.)	
	20798.1011	1	Panel Assy W/Decals (120V) (G9-2T HD 3 batch sel.)	
	20798.1005	1	Panel Assy W/Decals (230V, 240V) (G9-2 HD)	
	20798.1006	1	Panel Assy W/Decals (240V) (G9-2T HD)	
	20798.1009	1	Panel Assy W/Decals (120V) (G9-2 HD-S)	
	01380.0000	2	Screw, Truss Head #6-32 x .50"	
	01382.0002	2	Screw, Truss Head Blk #6-32 x .50"	
01518.0000	2	Washer, Screw Retaining #6		
10	10756.0000	1	Schematic/Time Chart 120V (W/O or 2 batch sel.)	
	10756.0002	1	Schematic/Time Chart 120V (3 batch sel.)	
	10756.0001	1	Schematic/Time Chart 120V (G9-2 HD-S)	
	10768.0000*	1	Schematic/Time Chart 240V	
11	05876.0000	1	Decal, Caution	
12	21620.1004	1	Cover Assy W/Decal SST (Includes screws and washers below and item 13)	
	21620.1011	1	Cover Assy W/Decal Blk (Includes screws and washers below and item 13)	
	01380.0000	2	Screw, Truss Head #6-32 x .50"	
	01382.0002	2	Screw, Truss Head Blk #6-32 x .50"	
	01518.0000	2	Washer, Screw Retaining #6	
13	24240.0000	1	Decal, Precision Grinder (Early Models)	
	33735.0002	1	Decal, Ground Fresh (Late Models)	
14	24239.0000	1	Decal, Control Panel (No batch sel.)	
	24239.0001	1	Decal, Control Panel (2 batch sel.) (Shown)	
	-----	1	Decal, Control Panel (3 batch sel.)(Not available)	

(Continued)

* Indicates the part number listed is for reference only. See DESCRIPTION for possible service replacement.

(Continued)

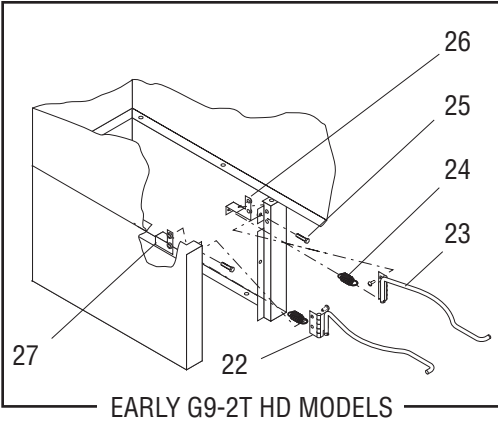

EARLY G9-2T HD MODELS

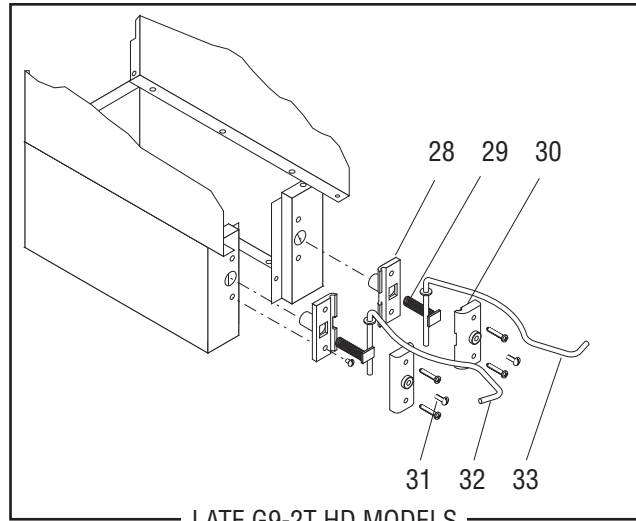

LATE G9-2T HD MODELS

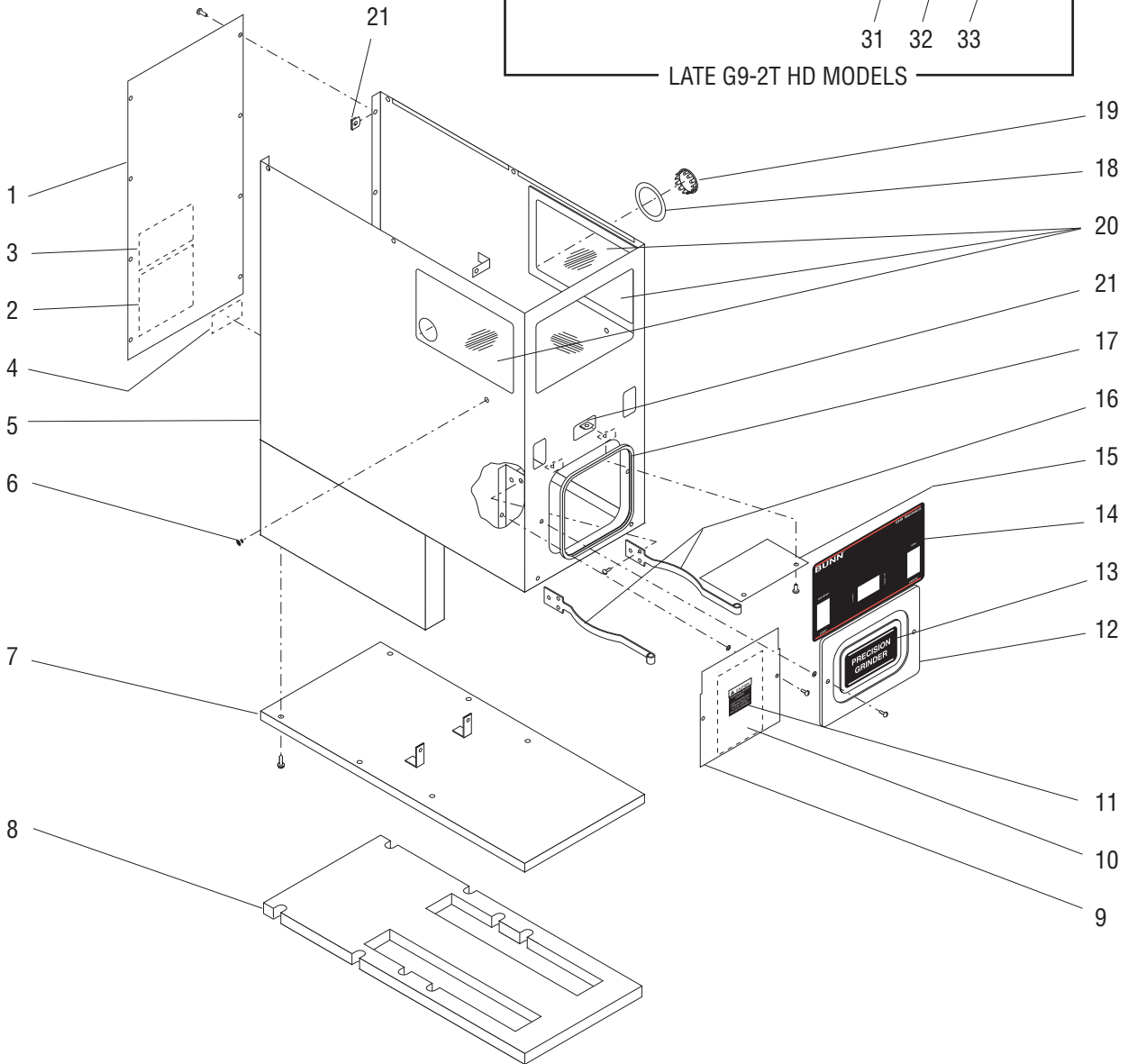

HOUSING, BASE AND PANELS

ITEM	PART NO.	QTY.	DESCRIPTION	
15	05827.0000	1	Plate, Switch Shield	
	02308.0000	2	Screw, Pan Head #8-32 x .38"	
	00912.0000	2	Clip, J-Type #8-32 (Late Models only)	
16	05839.0000	2	Funnel Rail	
	02308.0000	4	Screw, Pan Head #8-32 x .38"	
17	-----	1	Edging 19.15" (Order item 34)	
18	05884.0000	1	Decal, Motor Reset	
19	02999.0000	1	Plug, Hole 1.19" Dia.	
20	05814.0001	3	Window Assy (Includes adhesive)	
21	00917.0000	8	Clip, J-Type #8-32	
22	05771.0000	1	Funnel Rail, Left	Early Model G9-2T HD only
	02308.0000	2	Screw, Pan Head #8-32 x .38"	
23	05770.0000	1	Funnel Rail, Right	
	02308.0000	2	Screw, Pan Head #8-32 x .38"	
24	05781.0000	2	Spring	
25	05743.0000	2	Screw, Stop #8-32 x .75"	
26	05742.0000	1	Bracket, Right Spring	Late Model G9-2T HD only
27	05741.0000	1	Bracket, Left Spring	
28	32561.0000	2	Bracket, Inner Spring	
29	32570.0000	2	Spring	
30	39586.1000	2	Bracket, Outer Spring	
	01326.0008	4	Screw, Truss Head BLK #10-32 x 1.25"	
31	01317.0000	2	Screw, Adjustment, Truss Head BLK #8-32 x .50"	
32	32568.0001	1	Funnel Rail, Left	
33	32569.0001	1	Funnel Rail, Right	
34	38278.1002	-	Edging 36.0" (Cut to required length)	

* Indicates the part number listed is for reference only. See DESCRIPTION for possible service replacement.

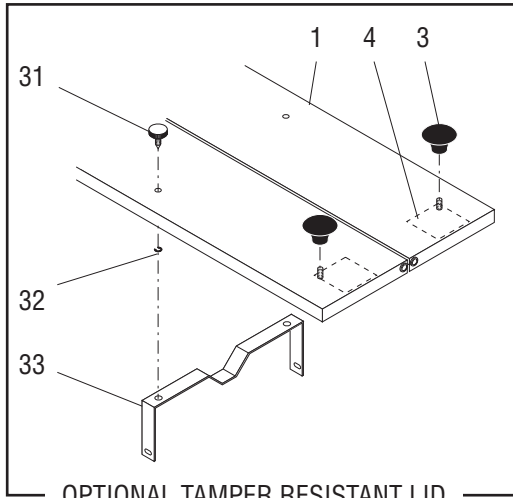

OPTIONAL TAMPER RESISTANT LID

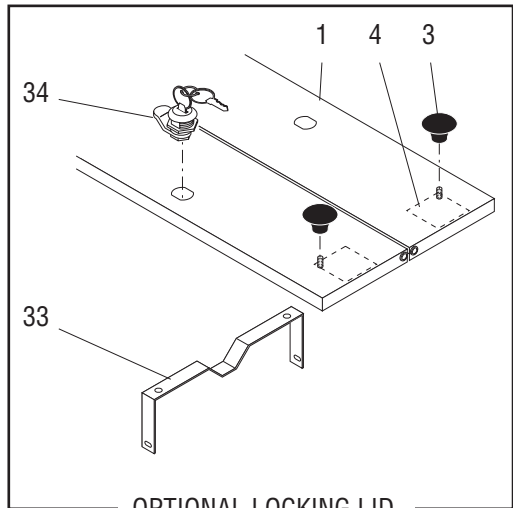

OPTIONAL LOCKING LID

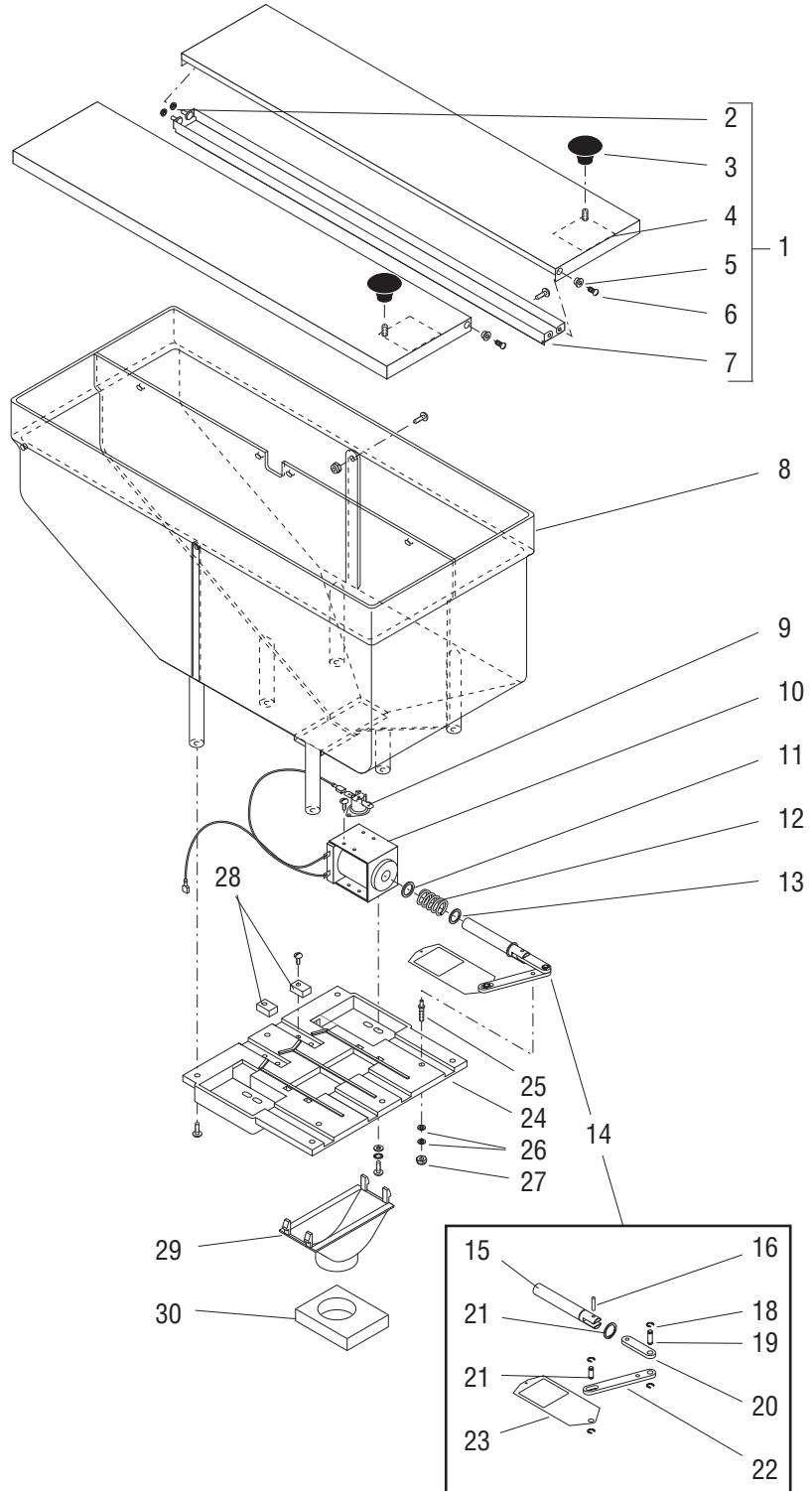

HOPPER, LID & SLIDE PLATE ASSEMBLY

ITEM	PART NO.	QTY.	DESCRIPTION	
-	24243.1000	1	Hopper Assy, 120V, SST Lid	} Includes items 1 thru 29
-	24243.1002	1	Hopper Assy, 120V, BLK Lid	
-	24243.1001	1	Hopper Assy, 240V	
1	24399.0000	1	Lid Assy, Hopper SST	} Includes items 2 thru 7
	24399.0004	1	Lid Assy, Hopper Blk	
	24399.0001	1	Lid Assy, Hopper Tamper Resistant	
	24399.0002	1	Lid Assy, Hopper Locking	
	02328.0000	4	Screw, Pan Head #6-32 x .38"	
2	26033.0001	2	Bearing, Snap-in (Early Models)	
	21438.0001	2	Washer, Shoulder .144" I.D. (Late Models)	
3	00725.0000	2	Knob	
4	05876.0000	2	Decal, Caution	
5	21438.0001	2	Washer, Shoulder .144" I.D.	
6	02328.0000	2	Screw, Pan Head #6-32 x .375"	
	01382.0007	2	Screw, Truss Head Blk #6-32 x .375"	
7	29358.0000	1	Channel, Hopper lid mounting	
8	05960.0000	1	Hopper Assy W/Inserts	} SST Grinders
	02367.0000	2	Screw, Truss Head #6-32 x .62"	
	01380.0000	2	Screw, Truss Head #6-32 x .50"	} Black Grinders
	01388.0002	2	Screw, Truss Head Blk #6-32 x .75"	
	02323.0000*	2	Screw, Truss Head Blk #6-32 x .50"	
	00991.0002	4	Nut, Hex #6 - 32	
9	23917.0000	2	Limit Thermostat	
	01311.0000	8	Screw, Truss Head #8-32 x .25"	
10	05939.0003	2	Solenoid Assy (120V)	
	05939.0004	2	Solenoid Assy (240V)	
	02308.0000	8	Screw, Pan Head #8-32 x .38"	
	01501.0000	8	Washer, Flat	
11	23923.0000	2	Washer, Fiber .063" Thick	
12	23918.0000	2	Spring	
13	23922.0000	2	Washer, Retaining .035" Thick	
14	05969.0000	2	Slide Plate/Linkage Assy (Includes items 15 thru 23)	
15	-----	2	Plunger (Not available seperately order item 14)	
16	02858.0000	2	Pin, Spring .125" x .50"	
17	23919.0000	2	Snap Ring	
18	01403.0000	8	E-Ring	
19	05914.0002	2	Pin, Linkage .19" x .39"	
20	05911.0001	2	Link, Slide Plate (Short)	
21	05914.0001	2	Pin, Linkage .19" x .30"	

(Continued)

* Indicates the part number listed is for reference only. See DESCRIPTION for possible service replacement.

(Continued)

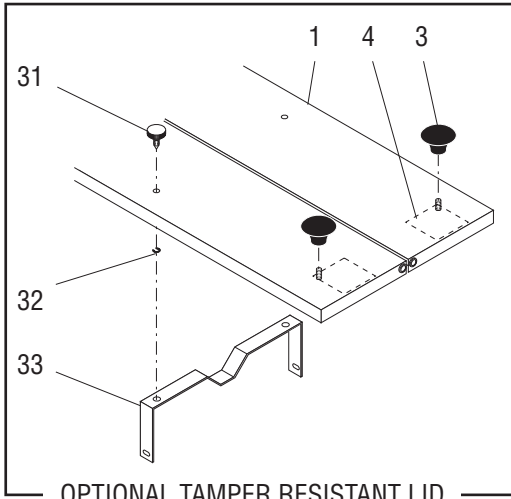

OPTIONAL TAMPER RESISTANT LID

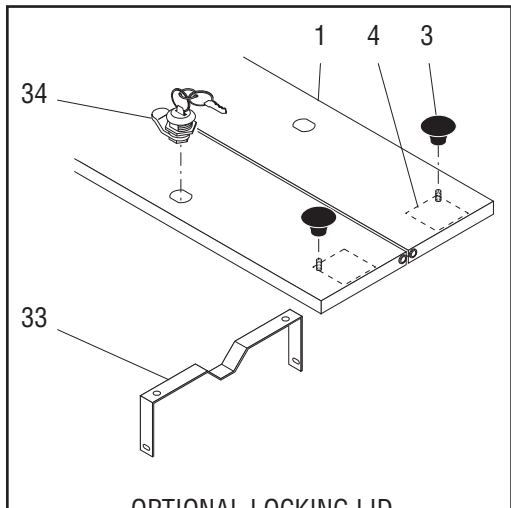

OPTIONAL LOCKING LID

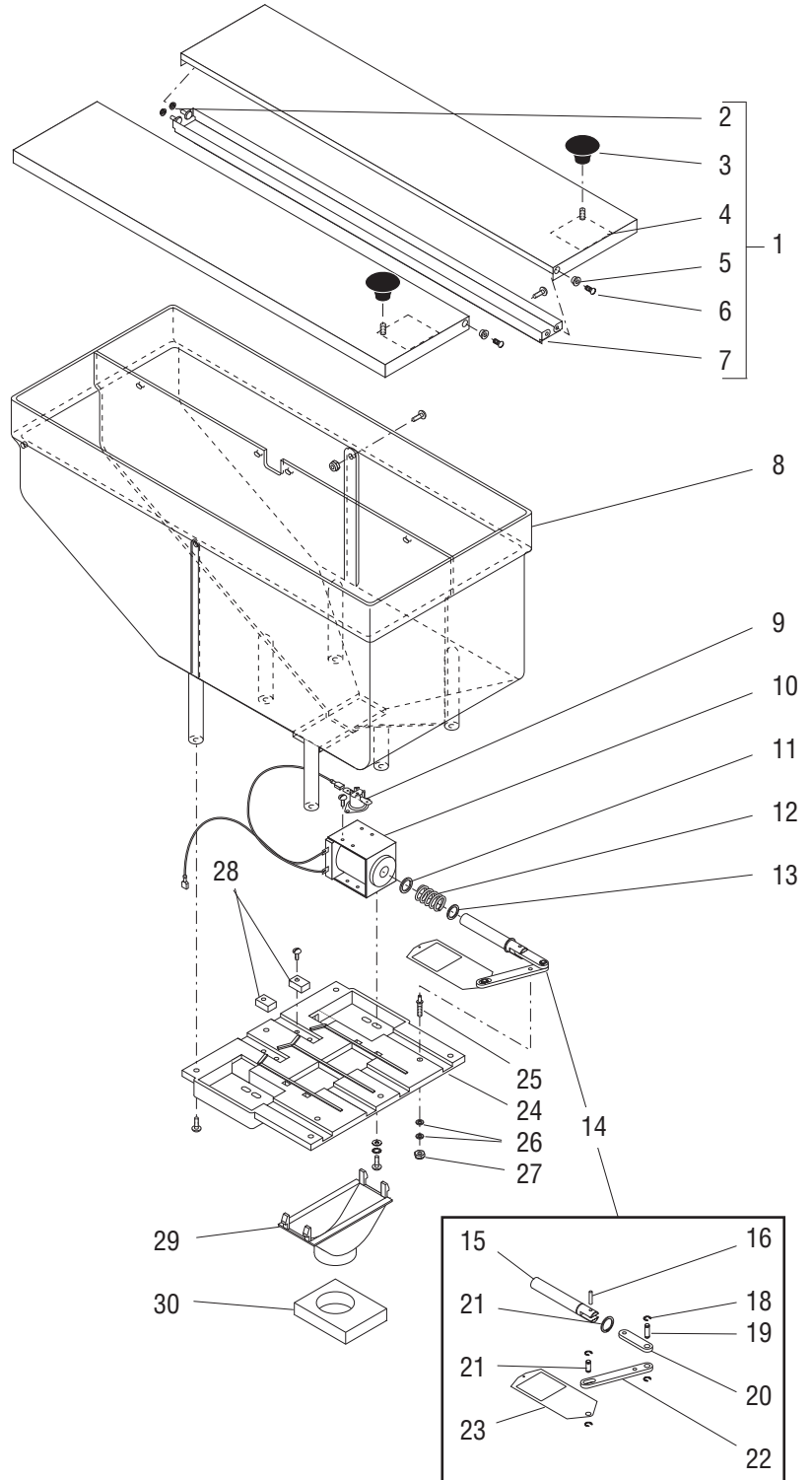

HOPPER, LID & SLIDE PLATE ASSEMBLY

ITEM	PART NO.	QTY.	DESCRIPTION
22	05910.0000	2	Link, Slide Plate (Long)
23	05912.1000	2	Slide Plate (Includes item 32)
24	05959.0001	1	Mounting Panel Assy, Slide Plate (Includes items 25, 26 & 27)
	01317.0000	6	Screw, Truss Head #8-32 x .50"
25	23920.0000	2	Pin, Pivot
26	01547.0000	4	Spacer .062" Thick
27	00991.0000	2	Nut, Elastic Lock #8-32
28	23921.0000	2	Block, Stop
	02336.0000	2	Screw, Truss Head #4-32 x .38" } Early Models
29	05916.0000	1	Collector
30	21457.0000	1	Gasket, Burr Housing/Collector
31	-----	2	Thumb Screw (Not available)
32	01403.0000	2	E-Ring
33	05970.0001*	1	Bracket, Lid Locking
34	11628.0000	2	Lid Lock Assy (Includes Keys) (New Keys should be made locally)
35	38549.0000	-	Gauge (Used to set depth of slide gate during replacement)(Not Illustrated)

* Indicates the part number listed is for reference only. See DESCRIPTION for possible service replacement.

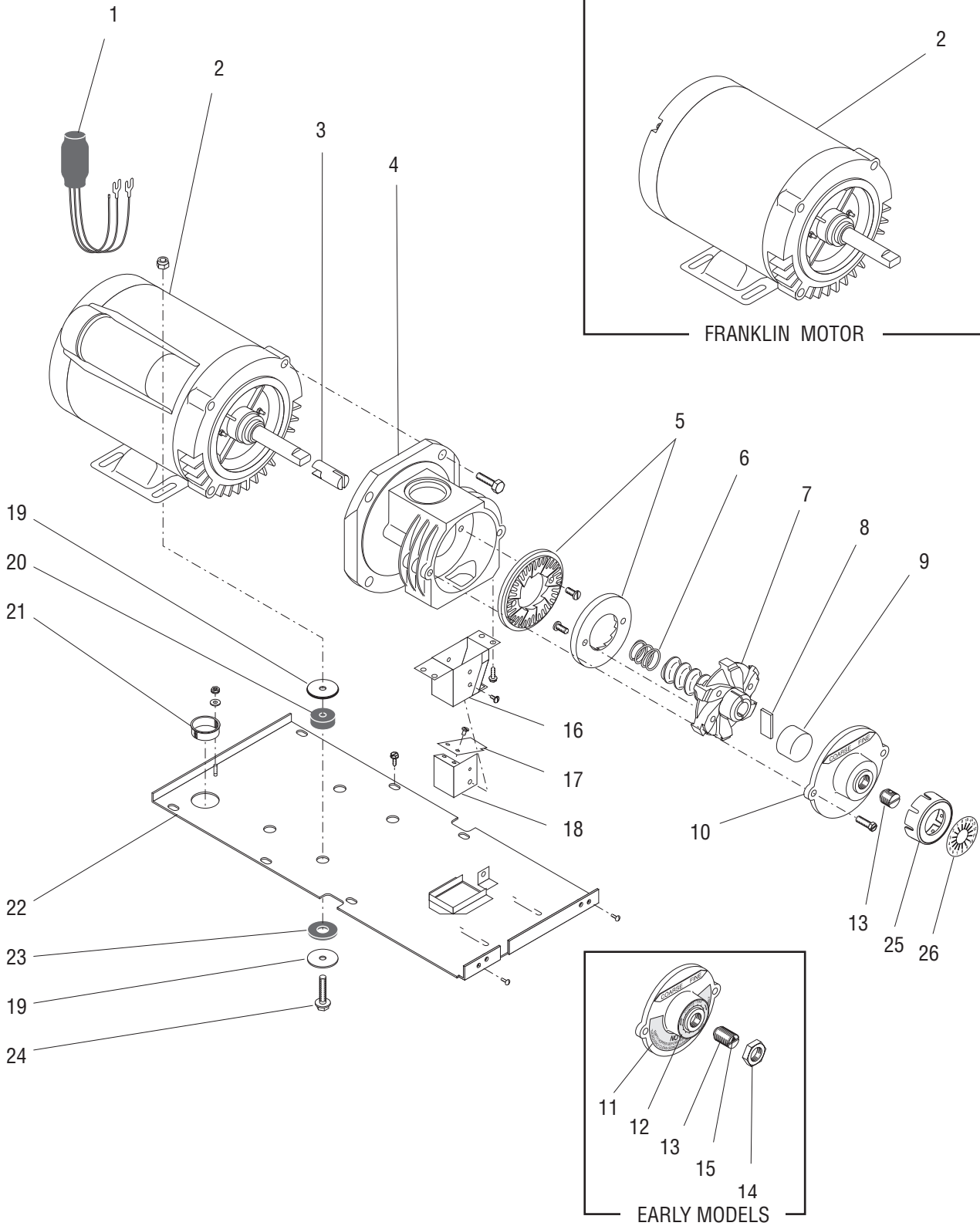

MOTOR, BURR HOUSING AND MOUNTING PLATE

ITEM	PART NO.	QTY.	DESCRIPTION
1	05965.0000	1	Snubber Assy, Timer (Early models)
2	-----	1	Motor Assy, 115V (Franklin) (Early models. Order late model Motor)
	11090.0008	1	Motor Assy, 115V (Marathon) (Late models)
	11090.0005	1	Motor Assy, 230V
3	11191.0001	1	Shaft Extension
4	11180.0000	1	Burr Housing
	02313.0000	4	Screw, Hex Head .38" - 16 x 1.0"
5	05861.1002	1	Burr Set (Includes 2 Burrs and Screws below)
	02314.0000	4	Screw, Pan Head .25" - 20 x .50"
6	11192.0000	1	Spring
7	11185.0001	1	Burr Auger Rotor/Spring Assy (Includes item 6)
8	05852.0001	1	Shear Plate
9	00622.0000	1	Cup, Burr Rotor (Standard)
	00622.0001	1	Cup, Burr Rotor (Heavy Duty)
10	05867.0000	1	Cap W/Decals, Burr Housing (Includes items 11 & 12)
	05867.0002	1	Cap & Adjusting Screw W/Decals, Burr Housing (Includes items 11 thru 14) (Also order item 15)
	20631.0000	2	Screw, Slotted Hex Head .25" - 20 x .75"
11	05868.0000	1	Decal, Housing Cover
12	05880.0000	1	Decal, Grind Indicator
13	35184.0000	1	Adjusting Screw (Also order item 15)
14	00989.0000	1	Nut, Locking
15	05796.0000	1	Decal, Adjusting Screw
16	05951.0000	1	Chute
	02330.0000	4	Screw, Slotted Hex Head #10-24 x .50"
17	05995.0000	1	Dechaffer Plate
	02327.0002	2	Screw, Pan Head #4-40 x .312"
18	05954.0000	1	Dechaffer Assy (Includes item 17)
	02328.0002	1	Screw, Pan Head #6-32 x .188"
19	01539.0000	8	Washer, Flat
20	05881.0000	4	Bushing
21	00718.0000	1	Bushing, 1.125" Dia. Hole
22	29883.0001	1	Plate, Motor Mounting (G9-2)
	29883.0002	1	Plate, Motor Mounting (G9-2T)
	02311.0000	6	Screw, Slotted Hex Head #10-32 x .50"
	01347.0000	2	Screw, Truss Head SST #6-32 x .38" (SST Grinders)
	01382.0007	2	Screw, Truss Head Blk Locking #6-32 x .38" (Black Grinders)
23	05882.0000	4	Washer, 1.50" Dia.
24	02312.0000	4	Screw, Hex Washer Head .312" -18 X 1.50"
	00987.0000	4	Nut, Lock .312" -18
25	34107.0000	1	Cap, Indicator Adjustment
26	34213.0000	1	Decal, Burr Adjustment

* Indicates the part number listed is for reference only. See DESCRIPTION for possible service replacement.

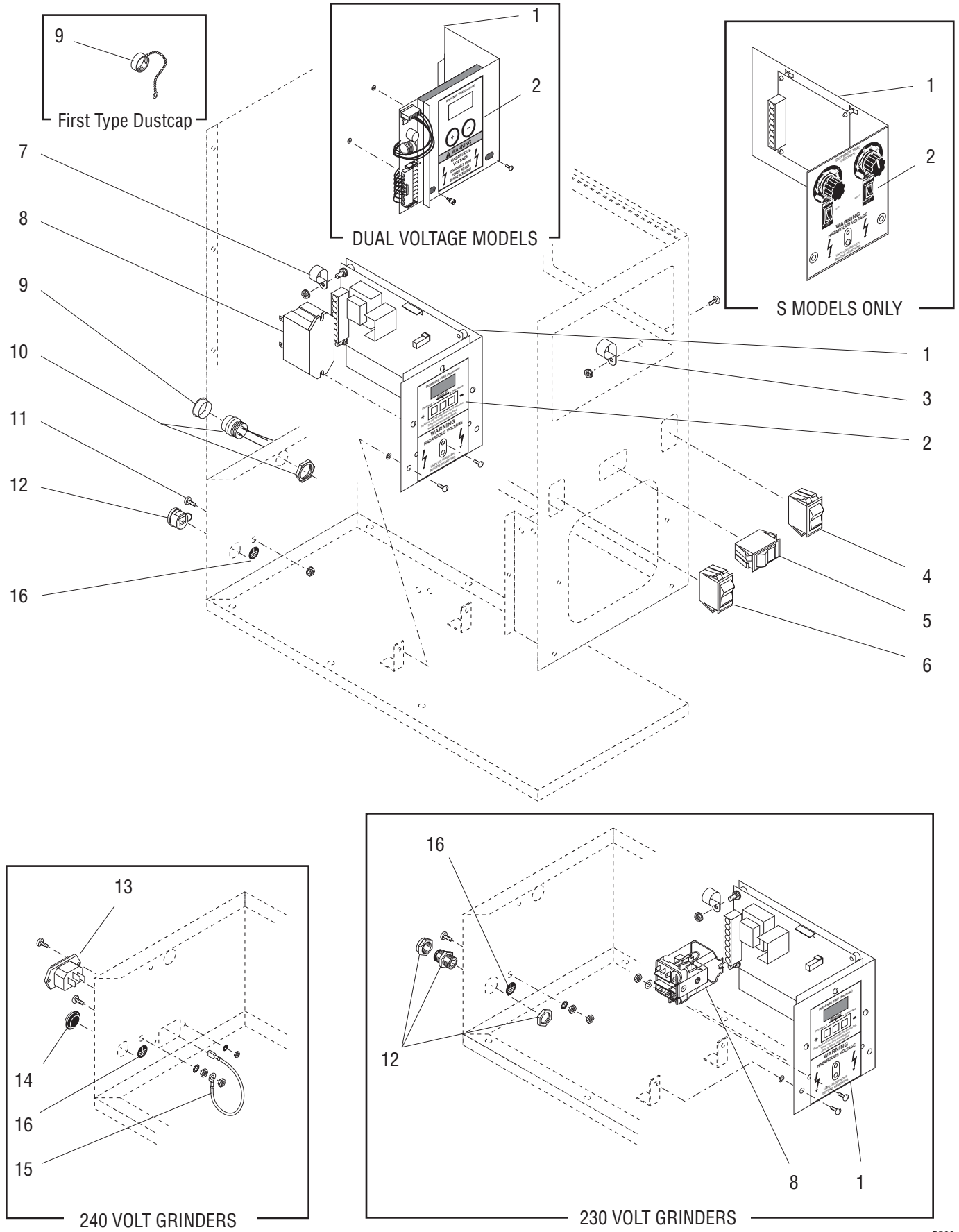

ELECTRICAL CONTROLS

ITEM	PART NO.	QTY.	DESCRIPTION	
1	32064.1000	1	Timer/Bracket Assy (120V Models)	} Includes screws and washers below and item 2
	32064.1001	1	Timer/Bracket Assy (230V Models)	
	25623.1000	1	Timer/Bracket Assy (120V) (S Models only)	
	28062.0000	1	Thumbscrew	
	01315.0000	2	Screw, Truss Head #8-32 x .375"	
	01516.0000	2	Washer, Screw Retaining	
2	-----	1	Decal, Timer (All other Models)	} Order item 1
	-----	1	Decal, Timer (S Models only)	
3	00603.0000	4	Clamp, cable .438" I.D. (2 less used on late grinders)	
	01315.0000	1	Screw, Truss Head #8-32 x .375" (SST Grinders)	
	02322.0002	1	Screw, Truss Head Black #8-32 x .375" (Black Grinders)	
	00970.0000	3	Nut, Keps #8-32 (2 less used on late grinders)	
4	06536.0000	1	Switch, 2 batch selection (SST Grinders with Multi Set Option only)	
	29107.0000	1	Switch, 3 batch selection (SST Grinders with Multi Set Option only)	
5	39178.0000	1	Switch, Hopper Selection	
6	05815.0000	1	Switch, Off/On/Start	
7	05920.0000	1	Clamp, cable .25" I.D.	} All except S Models
	00973.0000	1	Nut, Keps #6-32	
8	37711.1002	1	Relay (120V Grinders)	
	05892.0000	1	Relay (240V Grinders)	
	28034.0000	1	Relay (230V Grinders)	
	01347.0000	1	Screw, Truss Head #6-32 x .375"	
9	-----	1	Dustcap W/Chain (First type not available order second type cap)	
	27657.0000	1	Cap, Dust (Second type)	
10	12274.0002	1	Socket Assy W/Leads, Interface	
11	01326.0000	1	Screw, Ground Truss Head SST #10-32 x .25"	
	00971.0000	1	Nut, Keps #10-32	
12	01686.0000	1	Bushing, Strain Relief (120V Grinders)	
	05746.0000	1	Bushing, Strain Relief (230V Grinders)	
13	01908.0000	1	Power Connector	} 240 Volt Grinders only
	01362.0000	2	Screw, Oval Head #4-40 x .50"	
	01509.0000	2	Lockwasher, External Tooth #4	
	00937.0000	1	Nut, Hex #4-40	
14	05749.0001	1	Plug, .625" Dia.	
15	21016.0013*	1	Lead, Elect. Grn/Yel 4.0" (Ground)	} 240 Volt Grinders only
	01375.0000	1	Screw, Brass Pan Head #10-32 x .50"	
	01512.0000	1	Lockwasher, External Tooth #10	
	00909.0000	1	Nut, Brass #10-32	
16	00824.0000	1	Decal, Ground	

(Continued)

* Indicates the part number listed is for reference only. See DESCRIPTION for possible service replacement.

(Continued)

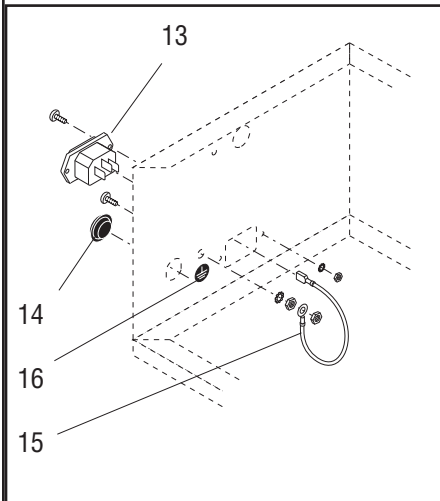
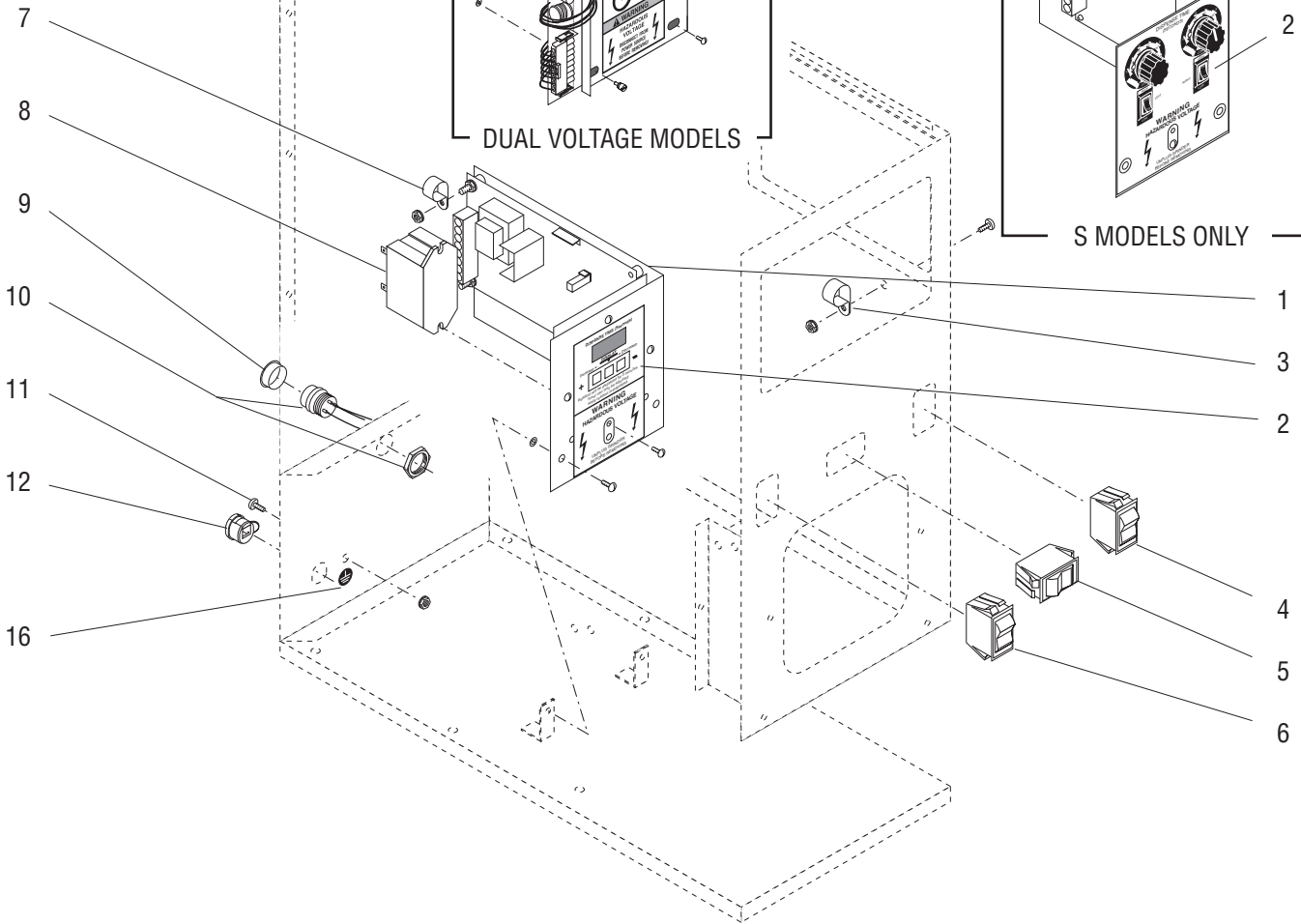
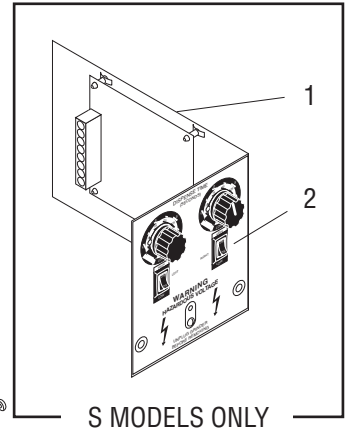
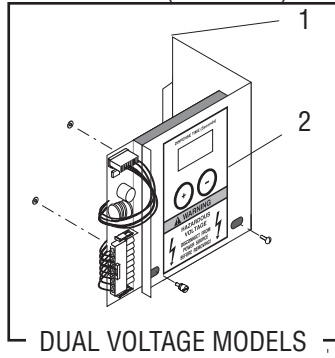
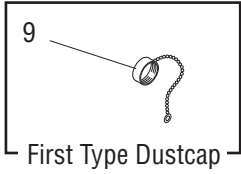

240 VOLT GRINDERS

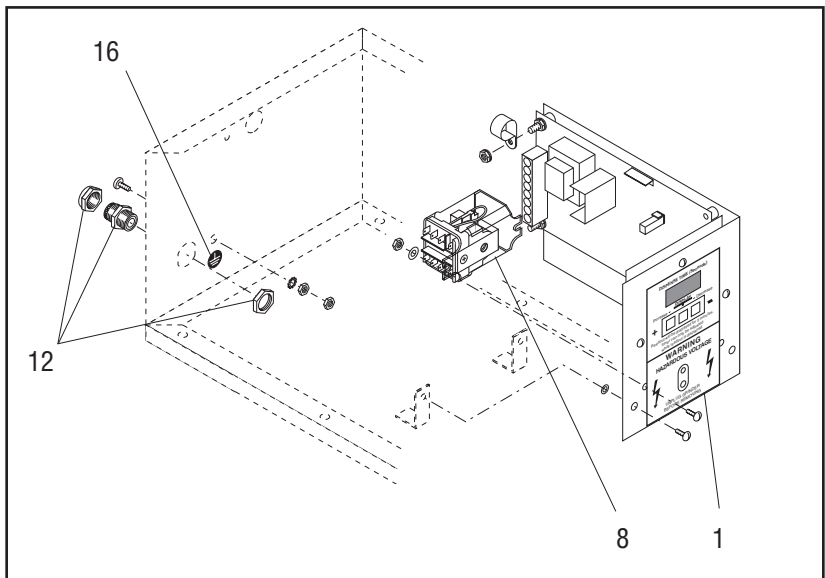

230 VOLT GRINDERS

P569

ELECTRICAL CONTROLS

ITEM	PART NO.	QTY.	DESCRIPTION
Note: The following items are not illustrated			
17	24241.1000	1	Wiring Harness, Main (120V Grinders)
	24330.0000	1	Wiring Harness, Main (240V Grinders)
	28126.0000	1	Wiring Harness, Main (230V Grinders)
18	24242.0000	1	Wiring Harness, Switch/Interface
19	-----	1	Wiring Harness, (3 batch selector switch)(Not available)
20	05188.0002	1	Cable, Interface
21	21005.0561	2	Lead, Electrical White/Black 10.0" (Hopper Solenoid to Main Harness)
22	40699.0004	1	Cord Assy, Power 120V
	27728.0001	1	Cord Assy, Power 230V
23	00669.0000	1	Plug, Hole .625" Dia. (Models W/O Interface)
24	22749.0000	2	Pad, Cable Tie (Self adhesive) (Early models)
25	00617.0000	2	Tie, Cable (Early models)

* Indicates the part number listed is for reference only. See DESCRIPTION for possible service replacement.

NUMERICAL INDEX

PART NO.	PAGE NO.	PART NO.	PAGE NO.	PART NO.	PAGE NO.	PART NO.	PAGE NO.
00603.0000	15	02858.0000	9	11090.0005	13	27728.0001	17
00617.0000	17	02999.0000	7	11090.0008	13	28034.0000	15
00622.0000	13	05188.0002	17	11180.0000	13	28062.0000	15
00622.0001	13	05741.0000	7	11185.0001	13	28126.0000	17
00669.0000	17	05742.0000	7	11191.0001	13	29107.0000	15
00718.0000	13	05743.0000	7	11192.0000	13	29358.0000	9
00725.0000	9	05746.0000	15	11628.0000	11	29883.0001	13
00824.0000	15	05749.0001	15	12274.0002	15	29883.0002	13
00909.0000	15	05752.0000	5	20545.0000	5	32064.1000	15
00912.0000	7	05770.0000	7	20631.0000	13	32064.1001	15
00917.0000	7	05771.0000	7	20798.1003	5	32561.0000	7
00937.0000	15	05781.0000	7	20798.1004	5	32568.0001	7
00970.0000	15	05796.0000	13	20798.1005	5	32569.0001	7
00971.0000	15	05809.0000	5	20798.1006	5	32570.0000	7
00973.0000	15	05809.0002	5	20798.1009	5	33735.0002	5
00987.0000	13	05814.0001	7	20798.1011	5	34107.0000	13
00989.0000	13	05815.0000	15	20798.1012	5	34213.0000	13
00991.0000	11	05816.0000	5	20798.1014	5	35184.0000	13
00991.0002	9	05827.0000	7	21005.0561	17	37711.1002	15
01311.0000	9	05839.0000	7	21016.0013	15	37881.0000	5
01311.0003	5	05844.1000	5	21438.0001	9	38549.0000	11
01315.0000	5,15	05852.0001	13	21457.0000	11	38578.1002	7
01317.0000	7,11	05861.1002	13	21620.1004	5	39178.0000	15
01326.0000	15	05867.0000	13	21620.1011	5	39586.1000	7
01326.0008	7	05867.0002	13	22749.0000	17	40699.0004	17
01347.0000	13,15	05868.0000	13	23917.0000	9		
01362.0000	15	05876.0000	5,9	23918.0000	9		
01375.0000	15	05880.0000	13	23919.0000	9		
01380.0000	5,9	05881.0000	13	23920.0000	11		
01382.0002	5	05882.0000	13	23921.0000	11		
01382.0007	9,13	05884.0000	7	23922.0000	9		
01388.0002	9	05892.0000	15	23923.0000	9		
01403.0000	9,11	05910.0000	11	24237.0000	5		
01501.0000	9	05911.0001	9	24239.0000	5		
01509.0000	15	05912.1000	11	24239.0001	5		
01512.0000	15	05914.0001	9	24240.0000	5		
01516.0000	15	05914.0002	9	24241.1000	17		
01518.0000	5	05916.0000	11	24242.0000	17		
01539.0000	13	05920.0000	15	24243.1000	9		
01547.0000	11	05921.0000	5	24243.1001	9		
01686.0000	15	05939.0003	9	24243.1002	9		
01908.0000	15	05939.0004	9	24330.0000	17		
02308.0000	7,9	05951.0000	13	24399.0000	9		
02311.0000	5,13	05954.0000	13	24399.0001	9		
02312.0000	13	05959.0001	11	24399.0002	9		
02313.0000	13	05960.0000	9	24399.0004	9		
02314.0000	13	05965.0000	13	25407.0000	5		
02322.0002	15	05969.0000	9	25407.0003	5		
02323.0000	9	05970.0001	11	25407.0004	5		
02327.0002	13	05995.0000	13	25408.0000	5		
02328.0000	9	06536.0000	15	25408.0002	5		
02328.0002	13	10756.0000	5	25408.0003	5		
02330.0000	13	10756.0001	5	25623.1000	15		
02336.0000	11	10756.0002	5	26033.0001	9		
02367.0000	9	10768.0000	5	27657.0000	15		