

# **BUNN**<sup>®</sup>

# *G1, G2 & G3*

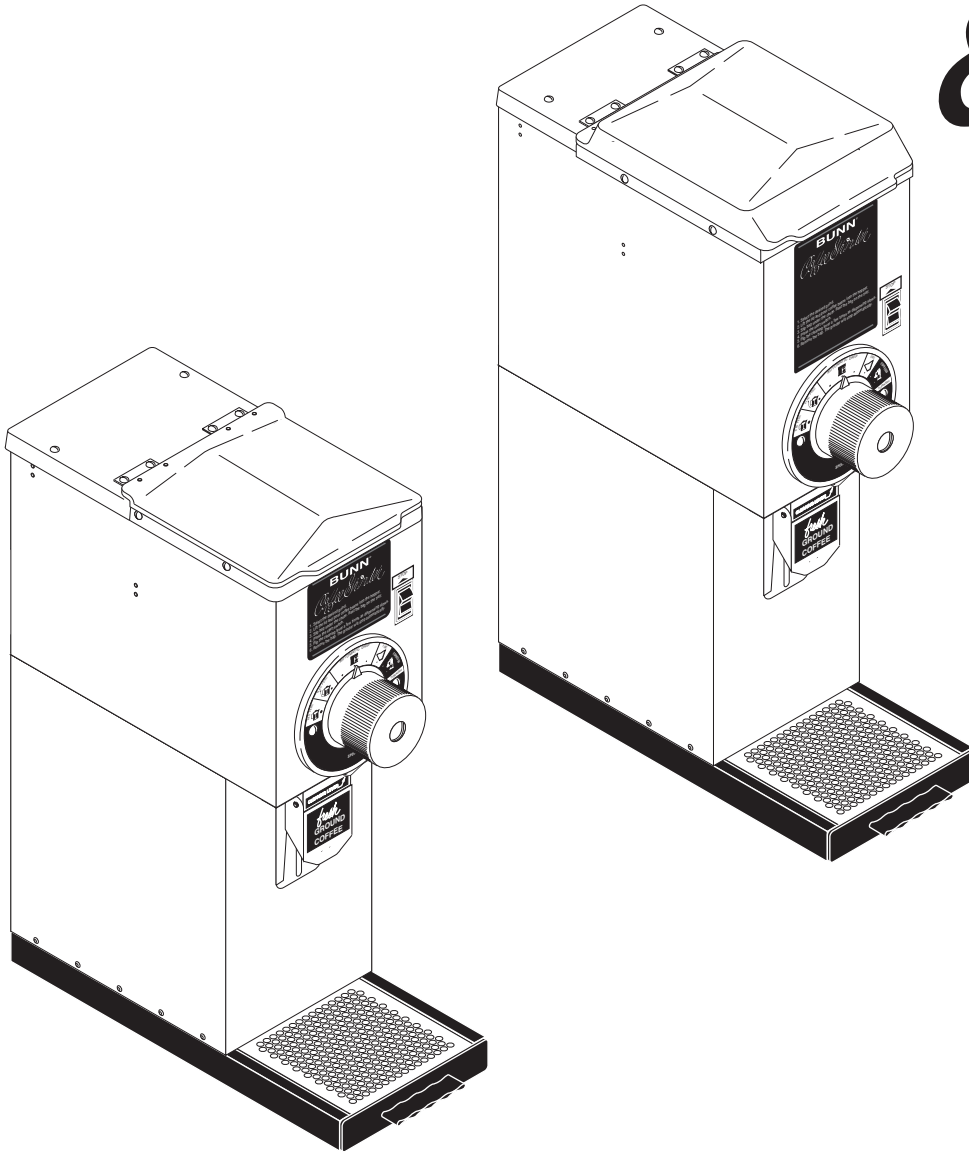

## **OPERATING & SERVICE MANUAL**

**BUNN-O-MATIC CORPORATION**

POST OFFICE BOX 3227

SPRINGFIELD, ILLINOIS 62708-3227

PHONE: (217) 529-6601 FAX: (217) 529-6644

## **BUNN-O-MATIC COMMERCIAL PRODUCT WARRANTY**

Bunn-O-Matic Corp. ("BUNN") warrants equipment manufactured by it as follows:

- 1) All equipment other than as specified below: 2 years parts and 1 year labor.
- 2) Electronic circuit and/or control boards: parts and labor for 3 years.
- 3) Compressors on refrigeration equipment: 5 years parts and 1 year labor.
- 4) Grinding burrs on coffee grinding equipment to grind coffee to meet original factory screen sieve analysis: parts and labor for 3 years or 30,000 pounds of coffee, whichever comes first.

These warranty periods run from the date of installation BUNN warrants that the equipment manufactured by it will be commercially free of defects in material and workmanship existing at the time of manufacture and appearing within the applicable warranty period. This warranty does not apply to any equipment, component or part that was not manufactured by BUNN or that, in BUNN's judgment, has been affected by misuse, neglect, alteration, improper installation or operation, improper maintenance or repair, damage or casualty. This warranty is conditioned on the Buyer 1) giving BUNN prompt notice of any claim to be made under this warranty by telephone at (217) 529-6601 or by writing to Post Office Box 3227, Springfield, Illinois 62708-3227; 2) if requested by BUNN, shipping the defective equipment prepaid to an authorized BUNN service location; and 3) receiving prior authorization from BUNN that the defective equipment is under warranty.

**THE FOREGOING WARRANTY IS EXCLUSIVE AND IS IN LIEU OF ANY OTHER WARRANTY, WRITTEN OR ORAL, EXPRESS OR IMPLIED, INCLUDING, BUT NOT LIMITED TO, ANY IMPLIED WARRANTY OF EITHER MERCHANTABILITY OR FITNESS FOR A PARTICULAR PURPOSE.** The agents, dealers or employees of BUNN are not authorized to make modifications to this warranty or to make additional warranties that are binding on BUNN. Accordingly, statements by such individuals, whether oral or written, do not constitute warranties and should not be relied upon.

If BUNN determines in its sole discretion that the equipment does not conform to the warranty, BUNN, at its exclusive option while the equipment is under warranty, shall either 1) provide at no charge replacement parts and/or labor (during the applicable parts and labor warranty periods specified above) to repair the defective components, provided that this repair is done by a BUNN Authorized Service Representative; or 2) shall replace the equipment or refund the purchase price for the equipment.

**THE BUYER'S REMEDY AGAINST BUNN FOR THE BREACH OF ANY OBLIGATION ARISING OUT OF THE SALE OF THIS EQUIPMENT, WHETHER DERIVED FROM WARRANTY OR OTHERWISE, SHALL BE LIMITED, AT BUNN'S SOLE OPTION AS SPECIFIED HEREIN, TO REPAIR, REPLACEMENT OR REFUND.**

In no event shall BUNN be liable for any other damage or loss, including, but not limited to, lost profits, lost sales, loss of use of equipment, claims of Buyer's customers, cost of capital, cost of down time, cost of substitute equipment, facilities or services, or any other special, incidental or consequential damages.

## USER NOTICES

Carefully read and follow all notices on the grinder and in this manual. They were written for your protection. All notices on the grinder are to be kept in good condition. Replace any unreadable or damaged labels.

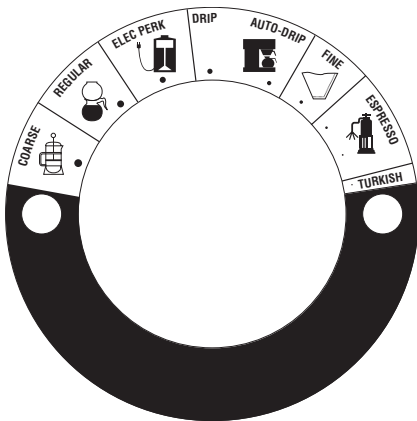

11075.0000

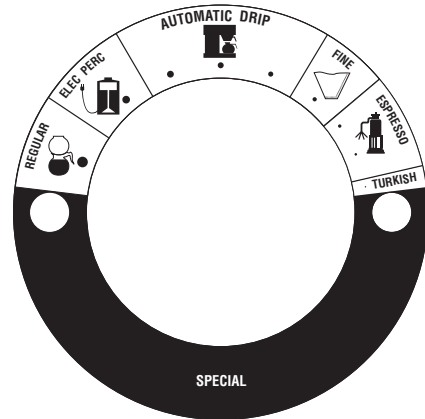

11075.0004 (SPECIAL)

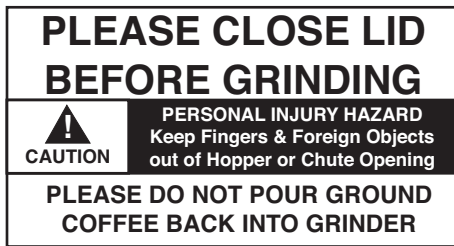

11076.0000



20545.0000

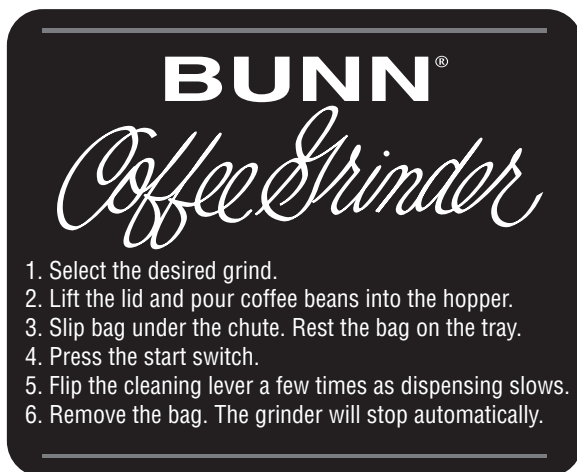

25152.0000 - G1

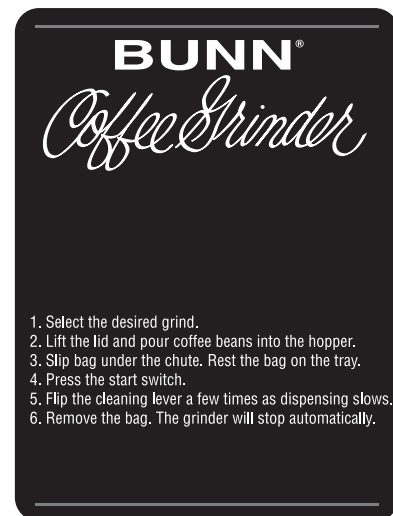

25153.0000 - G2 & G3

## ELECTRICAL REQUIREMENTS

The 120 volt and 240 volt grinders have an attached cordset and requires 2-wire, grounded service rated 120 volts ac and 240 volts ac, 15 amp, single phase, 60 Hz. The 230 volt grinders have a power connector and requires 2-wire, grounded service rated 230 volts ac, 15 amp, single phase, 50 Hz.

## INITIAL SET-UP

CAUTION - Unplug the grinder throughout the initial set-up.

1. Open the top lid. Clear all foreign objects and shipping materials from the hopper compartment and the entrance to the grind chamber.
2. Tip the machine gently, on its back, so it rests with approximately one inch of the bottom overhanging the work surface.
3. Remove the drawer from the base assembly.
4. Place the base against the grinder bottom and align the four sets of holes.
5. Securely fasten the base to the grinder bottom using the four screws and washers provided.
6. Raise the grinder to the upright position.
7. Insert the drawer into the base assembly.
8. The grinder can now be plugged-in and put into service.

## OPERATING CONTROLS

### Off/On/Start Switch

**OFF** - (upper position)

Switching to this position stops the operation of the grinder.

**ON** - (center, resting position)

The switch will return to this position after a grind cycle has begun and will remain in this position after grinding has ceased.

**START** - (lower, momentary position)

Pressing the switch initiates grinding only when a bag is in place behind the chute.

### Grind Selector

Allows the user to vary the grind for each bag of coffee. Each setting will provide precisely the same grind every time it is selected.

### Bag Sensor

Prevents the grinder from operating unless the back of a bag is in place behind the dispense chute.

*Do not attempt to bypass this safety device.*

## CLEANING

The use of a damp cloth rinsed in any mild, non-abrasive, liquid detergent is recommended for cleaning all surfaces on Bunn-O-Matic equipment. Regular cleaning will keep your grinder looking new for years

## COFFEE GRINDING

1. Turn the selector knob to align the red arrow with the desired grind.
2. Raise the top lid and add the whole bean coffee. Close the top lid.
3. Locate the back of a bag behind the dispense chute. (The grinder will not operate unless the bag is behind the chute.)
4. Allow the bag to rest on the screen beneath the chute.
5. Press the start switch.
6. Flip the cleaning lever a few times as dispensing slows.
7. Remove the bag when ground coffee is no longer dispensed from the chute. The grinder will stop automatically as the bag is removed.

**NOTE** - The start switch will have to be pressed again to continue the cycle if the bag is removed while grinding.

## ADJUSTMENT

1. Place an empty bag on the screen, with the back of the bag behind the dispense chute.
2. Start the grinder to clear the grind chamber. Leave grinder "ON".
3. Turn the Grind Selector knob to the "TURKISH" (fully clockwise) position.
4. Using a small flat blade screwdriver, loosen the two set screws on the left side of the grind selector knob.
5. Hold the knob in the "TURKISH" (fully clockwise) position with one hand.
6. Using a large flat blade screwdriver, slowly turn the adjusting screw in the center of the grind selector knob to the right (clockwise) until a metallic whine can be heard due to the rubbing of the grinding burrs.
7. While holding the knob in the "TURKISH" (fully clockwise) position, back off the screw to the left (counter-clockwise) just until the metallic whine ceases.
8. Turn-off the grinder.
9. Push the knob against the dial plate and tighten both set screws on the left side of the grind selector knob.
10. Turn the grinder on and listen again for the metallic whine with the grind selector knob in the turkish (fully clockwise) position. If the metallic whine is heard, repeat steps 7 through 10 until the sound ceases.
11. If no metallic whine is heard, the grinding burrs are adjusted properly.

## TROUBLESHOOTING

A troubleshooting guide is provided to suggest probable causes and remedies for the most likely problems encountered. If the problem remains after exhausting the troubleshooting steps, contact the Bunn-O-Matic Technical Service Department.

- Inspection, testing, and repair of electrical equipment should be performed only by qualified service personnel.

- WARNING** –
- Exercise extreme caution when servicing electrical equipment.
  - Disconnect the grinder from the power source when servicing, except when electrical tests are specified.
  - Follow recommended service procedures
  - Replace all protective shields or safety notices

<b>PROBLEM</b>	<b>PROBABLE CAUSE</b>	<b>REMEDY</b>
Grinder will not start.	1. No power or incorrect voltage.	(A) Plug-in the grinder. (B) Check the voltage at the wall outlet with a voltmeter. It must be 120 volts ac for two wire 120 volt models or 230 volts ac for two wire 230 volt 50 Hz models or 240 volts ac for two wire 240 volt 60 Hz models.
	2. Off/On/Start Switch.	(A) Press the switch to the “START” position.  (B) Refer to Service - Off/On/Start Switch for testing procedures. See page 16.
	3. Bag sensor.	(A) The receiving bag must be placed on the tray screen and have the back of the bag behind the dispense chute to activate the sensor switch.

## TROUBLESHOOTING (cont.)

<b>PROBLEM</b>	<b>PROBABLE CAUSE</b>	<b>REMEDY</b>
Grinder will not start. (cont.)	3. Bag Sensor. (cont.)	(B) Refer to <i>Service - Bag Sensor Switch</i> for testing and adjustment procedures. See page 9.
	4. Motor overload protector.	Remove the plug located on the right side of the housing. Press the red “Reset” button visible through the opening. Listen carefully for a “click”. This resets the motor protection circuit and may indicate that an overload has been encountered by the motor. (An overload can occur when something other than coffee is inserted into the hopper for grinding. Refer to <i>Service - Motor</i> for disassembly.) See page 10 for AC Motors or see page 13 for DC Motors.
Grinder will not shut off.	1. Off/On/Start Switch	(A) Move the switch to the “OFF” position.  (B) Refer to <i>Service - Off/On/Start Switch</i> for testing procedures. See page 16.
	2. Bag Sensor	(A) Remove bag from under the dispense chute.  (B) Refer to <i>Service - Bag Sensor Switch</i> for testing procedures. See page 9.
	3. Relay	Refer to <i>Service - Relay</i> for testing procedures. See page 18.

## TROUBLESHOOTING (cont.)

<b>PROBLEM</b>	<b>PROBABLE CAUSE</b>	<b>REMEDY</b>
Grinder starts, but will not dispense.	1. Hopper	Coffee must be poured into hopper before grinding.
	2. Entrance to grind chamber	Foreign materials must not block the opening at the bottom of the hopper.
	3. Shear Plate	Remove both black fillister head screws holding the grinder selector dial plate to the grinder. Carefully remove the dial plate and rotor cup. Inspect the shear plate for wear. Replace if excessively worn or damaged.



## SERVICE

This section provides procedures for testing and replacing various major components used in this grinder should service become necessary. Refer to Troubleshooting for assistance in determining the cause of any problem.

### COMPONENT ACCESS

**WARNING** - Unplug the grinder before the removal of any panel or the replacement of any component.

All components are accessible by the removal of the top lid, hopper, and rear panel.

The top lid is attached with two #6-32 screws, the hopper assembly is attached with four #6-32 screws and the rear panel is attached with ten #8-32 screws.

### CONTENTS

Bag Sensor Switch.....	9
Motor and Grind Chamber (AC) .....	10
Motor and Grind Chamber (DC) .....	13
Off/On/Start Switch .....	16
Rectifier .....	17
Relay .....	18
Wiring Diagrams .....	20,21

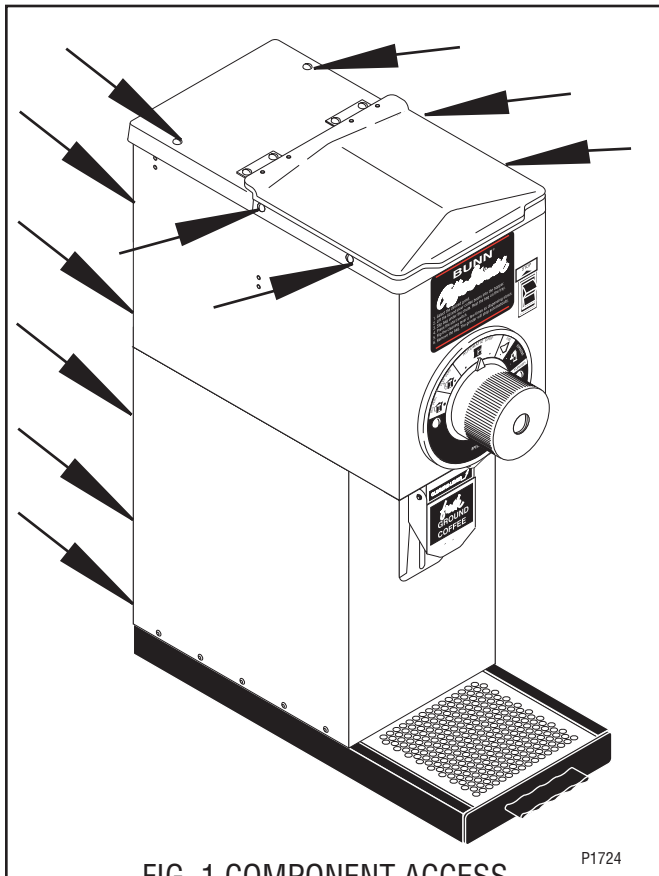

FIG. 1 COMPONENT ACCESS

P1724

## BAG SENSOR SWITCH

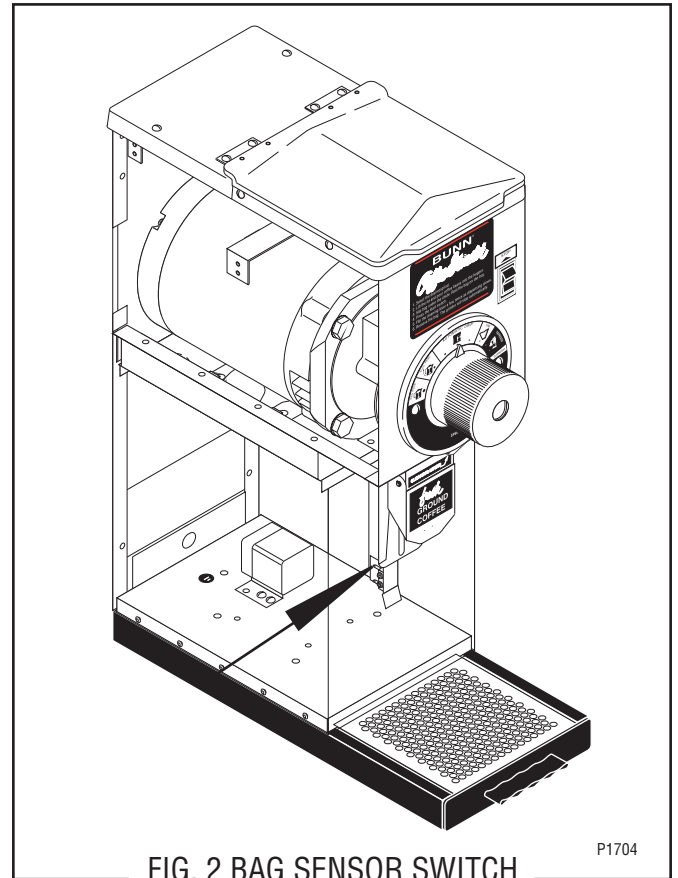

FIG. 2 BAG SENSOR SWITCH

P1704

### Location:

The bag sensor switch is located inside the lower front of the grinder housing behind the coffee dispensing chute.

### Test Procedure:

1. Disconnect the grinder and place a coffee bag behind the dispense chute.
2. Remove the white/violet wire from the bag sensor switch.
3. Check the voltage across the white/violet wire from the bag sensor switch and the white wire, red/black wire or red wire on the relay coil with a voltmeter. Hold the Off/On/Start switch in the "START" (lower) position and connect the grinder to the power source. The indication must be:
  - a. 120 volts ac for two wire 120 volt models.
  - b. 230 volts ac for two wire 230 volt models.
  - c. 240 volts ac for two wire 240 volt models.

## SERVICE (cont)

### BAG SENSOR SWITCH (cont.)

4. Disconnect the grinder from the power source.

If voltage is present as described, proceed to #5.

If voltage is not present as described, refer to the Wiring Diagrams and check the grinder wiring harness.

5. Check for continuity across the terminals on the bag sensor switch.

If continuity is present as described, reconnect the wires, the switch is operating properly.

If continuity is not present as described, replace the switch.

#### Removal and Replacement:

1. Remove the wires from the switch.
2. Remove the two #8-32 keps nuts securing the bag sensor assembly to the grinder housing.
3. Remove the two #2-56 screws, nuts and external tooth lockwashers securing the switch to the bag sensor assembly.
4. Mount the new switch to the bag sensor assembly using two #2-56 screws, nuts and external tooth lockwashers. Adjust the assembly by locating the corner of the switch housing to the top edge of the black metal mounting bracket.
5. Reattach the sensor assembly to the grinder housing and secure with two #8-32 keps nuts.
6. Refer to Fig. 3 when reconnecting the wires.

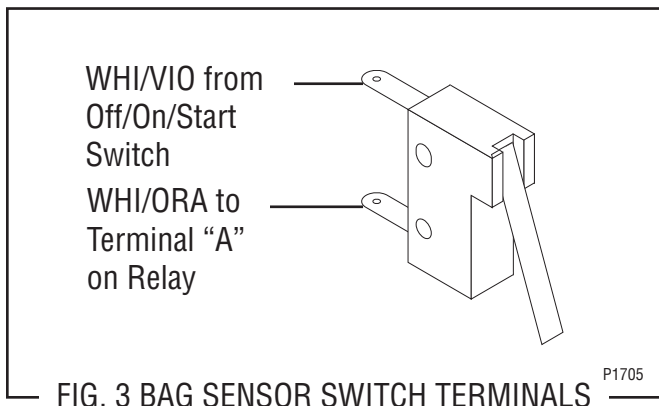

FIG. 3 BAG SENSOR SWITCH TERMINALS

## AC MOTOR AND GRIND CHAMBER

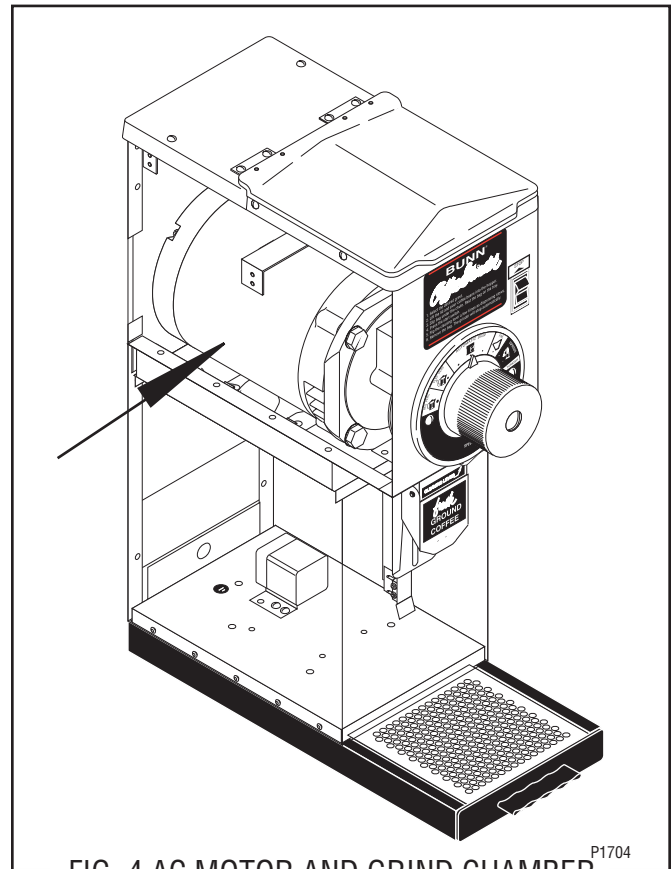

FIG. 4 AC MOTOR AND GRIND CHAMBER

#### Location:

The motor is located inside the upper part of the grinder housing.

#### Test Procedure:

1. Remove the plug located on the right side of the housing. Press the red "Reset" button visible through the opening. Listen carefully for a "click". This resets the motor protection circuit and may indicate that something other than coffee was inserted into the hopper for grinding.

If the grinder remains unable to start, proceed to #2. If the grinder stops operating shortly after starting, refer to removal and replacement instructions and inspect for foreign materials.

2. Disconnect the grinder from the power source and place a coffee bag behind the dispense chute.
3. Remove the electrical access panel at the rear of the motor.

## SERVICE (cont.)

### AC MOTOR AND GRIND CHAMBER (cont.)

4. Check the voltage across the white, red or red/black and white/blue wires on terminals L1 & L2 with a voltmeter. Connect the grinder to the power source. When the Off/On/Start switch is momentarily placed in the "START" (lower) position and then left in the "ON" (center) position and a bag is in place behind the coffee dispense chute. Plug-in the grinder. The indication must be:
  - a. 120 volts ac for two wire 120 volt models.
  - b. 230 volts ac for two wire 230 volt models
  - c. 240 volts ac for two wire 240 volt models.
5. Disconnect the grinder from the power source.

If voltage is present as described replace the motor. If voltage is not present as described, reconnect the white, red or red/black and white/blue wires to the motor, refer to the Wiring Diagrams and check the grinder wiring harness.

#### Removal and Replacement - Motor (Refer to FIG. 6):

1. Remove the plate on the rear of the motor and disconnect all wires from the motor.
2. Remove the two .250"-20 screws (1) securing grind selector dial plate and grind selector knob (2) to the grind chamber. Remove dial plate and selector knob as an assembly.
3. Slide burr (7), auger rotor/spring assembly (3), shear plate (4) and burr rotor cup (5) off the grinder motor shaft as an assembly.
4. Remove the two .250"-20 screws (8) securing the stationary burr (9) to the grind chamber.
5. Remove bushing (10) and shaft extension (11) from the grinder motor shaft.
6. Remove the two #8 thread forming screws (12) securing the fill plate (13) to grinder housing and remove plate (13).
7. Remove the four #10-24 screws (14) securing the chute assembly (15) to the grind chamber and remove chute assembly (15).
8. Remove the four .250"-20 screws, flat washer and rubber washers securing the motor to the mounting bracket.
9. Remove motor out the rear of the grinder housing.
10. Remove the four .250"-20 cage nuts from the motor mount.

11. Clean all grinding burrs and mounting surfaces before reassembly.
12. Install the four .250"-20 cage nuts on the new motor.
13. Place the new motor with hopper collar and bushing into position on the bushings on the motor mounting bracket.
14. Using four .250"-20 screws, flat washers and rubber washers secure the motor to the mounting bracket.
15. Install stationary burr (9) to the grind chamber housing using two .250"-20 screws.
16. Install burr (7) and burr auger rotor/spring assembly (3) on to motor shaft.
17. Install motor shaft extension (11) on motor shaft.
18. Align the slot in the motor shaft extension (11) with the slot in the burr auger rotor/spring assembly (6) and install shear plate (4).
19. Install burr rotor cup (5).
20. Install grind selector dial plate and grind selector knob assembly on the grind chamber housing and secure with two .250"-20 screws.
21. Refer to Fig. 5 and reconnect the wires.
22. Refer to *ADJUSTMENTS* on page 5 and reset the burrs.

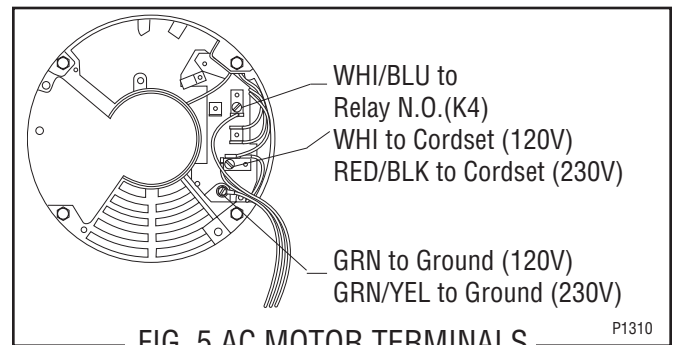

#### Removal and Replacement - Grind Chamber - Refer to Fig. 6:

1. Loosen the two set screws (16) securing the grind selector knob to the grind selector dial plate (18) and remove knob.
2. Remove the adjusting screw w/bearing (19). Inspect adjusting screw w/bearing for wear. Replace if excessively worn or damaged.

## SERVICE (cont.)

### AC MOTOR AND GRIND CHAMBER (cont.)

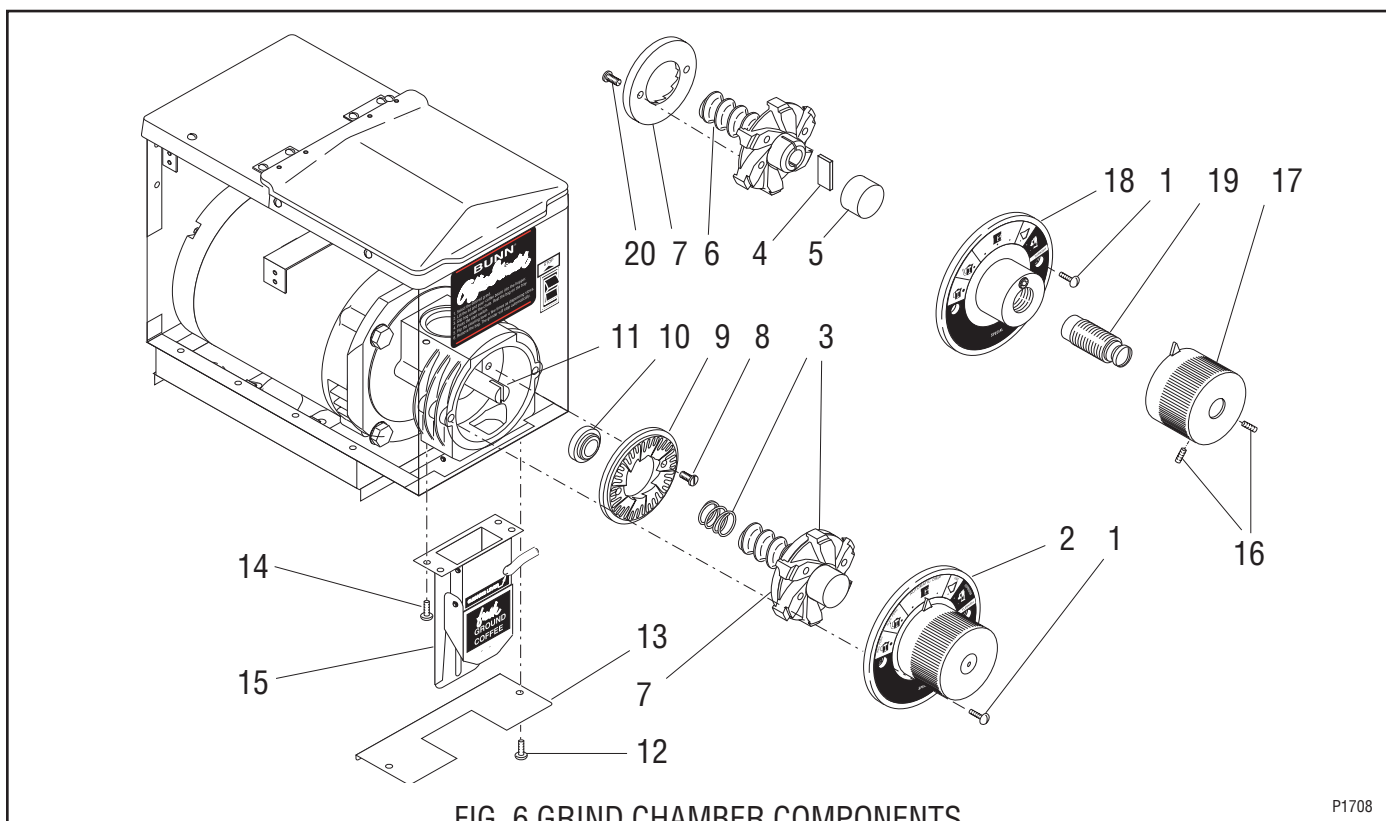

3. Remove the two .250"-20 screws (1) securing the grind selector dial plate (18) to the grind housing.
4. Slide burr auger rotor/spring assembly (3) off of the grinder motor shaft with burr rotor cup (5), shear plate (4) and burr (7) as an assembly.
5. Remove burr rotor cup (5) and shear plate (4) from burr auger rotor/spring assembly (6). Inspect shear plate (4) for wear. Replace if excessively worn or damaged.
6. Remove the two .250" screws (20) securing burr (7) to burr auger rotor/spring assembly (6) and remove burr (7). Inspect burr (7) for wear. Replace if excessively worn or damaged.
7. Remove the two .250"-20 screws (8) securing the stationary burr (9) to grind chamber housing and remove burr. Inspect for wear. Replace if excessively worn or damaged.
8. Clean all grinding burrs and mounting surfaces before reassembly.
9. Remove bushing (10) and shaft extension (11) from grinder motor shaft. Inspect for wear. Replace if excessively worn or damaged.
10. Install shaft extension (11) and bushing (10) onto the grinder motor shaft.
11. Install stationary burr (9) inside the grind chamber and secure with two .250" -20 screws (8).
12. Install burr (7) on burr auger rotor/spring assembly (6) securing with two .250"-20 screws (20).
13. Slide burr auger rotor/spring assembly and burr (3) onto the motor shaft.
14. Align the slot in the shaft extension and the slot in the burr auger rotor/spring assembly and install shear plate (4).
15. Install burr rotor cup (5) onto the burr auger rotor/spring assembly (6).
16. Install the adjusting screw w/bearing (19) into the grind selector dial plate (18).

**NOTE:** Burrs are serviced in sets of two with hardware.

## SERVICE (cont.)

### AC MOTOR AND GRIND CHAMBER (cont.)

17. Install grind selector dial plate (18) with adjusting screw w/bearing (19) onto the grind chamber and secure with two .250"-20 screws (1).
18. Install grind selector knob (17) onto the grind selector dial plate (18).

**NOTE:** Refer to *ADJUSTMENTS* and reset the burrs.

### DC MOTOR AND GRIND CHAMBER - G1MD ONLY

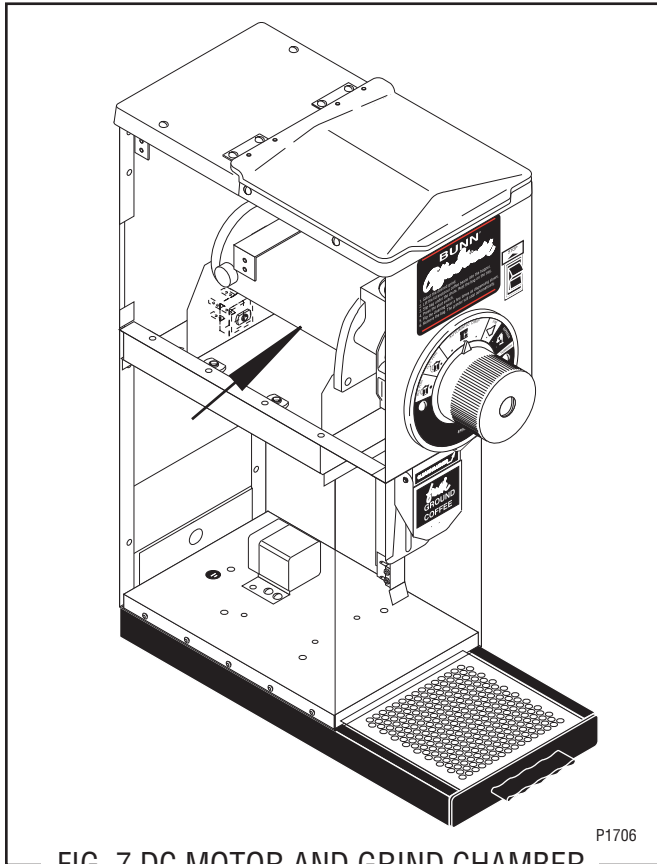

FIG. 7 DC MOTOR AND GRIND CHAMBER

#### Location:

The motor is located inside the upper part of the grinder housing.

#### Test Procedures:

1. Remove the rear panel. Press the red "Reset" button visible on the rear of the motor. Listen carefully for a "click". This resets the motor protection circuit and may indicate that something other than coffee was inserted into the hopper for grinding.

If the grinder remains unable to start, proceed to #2.

If the grinder stops operating shortly after starting, refer to removal and replacement instructions and inspect for foreign materials.

2. Disconnect the grinder from the power source and place a coffee bag behind the dispense chute.
3. Remove the black wire from the rectifier (+) terminal and the red wire from the (-) terminal.
4. Check the voltage across the (+) and (-) terminals with a voltmeter. Connect the grinder to the power source. When the Off/On/Start switch is momentarily placed in the "START" (lower) position and then left in the "ON" (center) position and a bag is in place behind the coffee dispense chute. The indication must be approximately 108 volts dc.
5. Disconnect the grinder from the power source.

If voltage is present as described replace the motor. If voltage is not present as described, reconnect the white or red and white/blue wires to the motor, refer to the Wiring Diagrams and check the grinder wiring harness.

#### Removal and Replacement - Motor (Refer to Fig. 9)

1. Disconnect all wires from the motor.
2. Remove the two .250"-20 screws (1) securing grind selector dial plate and grind selector knob (2) to the grind chamber. Remove dial plate and selector knob as an assembly.
3. Slide burr (7), auger rotor/spring assembly (3) and burr rotor disc (4) off the grinder motor shaft as an assembly.
4. Remove the two .250"-20 screws (8) securing the stationary burr (9) to the grind chamber.
5. Remove bushing (10) and washer (11) from the grinder motor shaft.
6. Remove the two #8 thread forming screws (12) securing the fill plate (13) to grinder housing and remove plate (13).
7. Remove the four #10-24 screws (14) securing the chute assembly (15) to the grind chamber and remove chute assembly (15).
8. Disconnect all the wires from the rectifier (23).
9. Remove the four .312"-18 screws (20), rubber washers (22) and flat washers (21) securing the motor and bracket to the grinder housing bracket.

## SERVICE (cont.)

### DC MOTOR AND GRIND CHAMBER - G1MD ONLY (cont.)

10. Remove motor and bracket out the rear of the grinder housing.
11. Remove the two .250"-20 screws securing the motor to the front of the mounting bracket.
12. Remove the two #10-32 screws securing the motor to rear of the mounting bracket.
13. Remove motor from bracket.
14. Clean all grinding burrs and mounting surfaces before reassembly.
15. Place the new motor with hopper collar into position on the motor mounting bracket.
16. Using two .250"-20 screws secure the motor to the front of the mounting bracket.
17. Using two #10-32 screws secure the motor to the rear of the mounting bracket
18. Install motor and bracket through the rear of the grinder, position on the grinder housing bracket and secure with four .312"-18 screws (20), rubber washers (22) and flat washers (21).
19. Install stationary burr (9) to the grind chamber housing using two .250"-20 screws (8).
20. Install burr (7), burr auger rotor/spring assembly (3) and burr rotor disc (4) on to motor shaft.
21. Install grind selector dial plate and grind selector knob assembly (2) on the grind chamber housing and secure with two .250"-20 screws.
22. Refer to Fig. 8 and reconnect the wires to the motor and Fig. 13 and reconnect the wires to the rectifier.
23. Refer to *ADJUSTMENTS* on page 5 and reset the burrs.

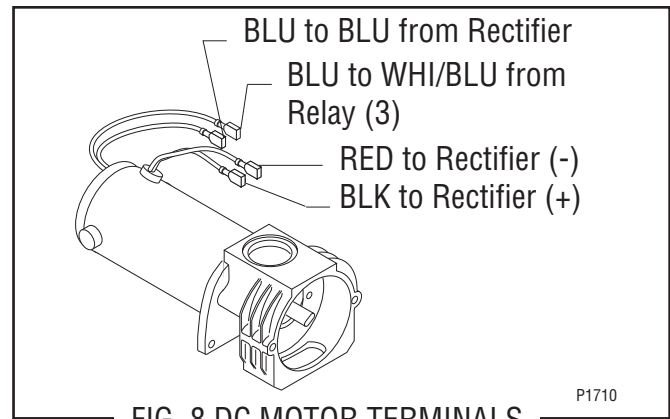

### Removal and Replacement - Grind Chamber - Refer to Fig. 9:

1. Loosen the two set screws (16) securing the grind selector knob to the grind selector dial plate (18) and remove knob.
2. Remove the adjusting screw w/bearing (19). Inspect adjusting screw w/bearing for wear. Replace if excessively worn or damaged.
3. Remove the two .250"-20 screws (1) securing the grind selector dial plate (18) to the grind housing and remove plate.
4. Slide burr auger rotor/spring assembly (3) off of the grinder motor shaft with burr (7) as an assembly.
5. Remove the two .250"-20 screws (5) securing burr (7) to burr auger rotor/spring assembly (6), remove burr (7) and burr rotor disc (4). Inspect burr (7) for wear. Replace if excessively worn or damaged.
6. Remove the two .250"-20 screws (8) securing the stationary burr (9) to grind chamber housing and remove burr. Inspect for wear. Replace if excessively worn or damaged.

**NOTE:** Burrs are serviced in sets of two with hardware.

7. Remove bushing (10) and washer (11) from grinder motor shaft. Inspect for wear. Replace if excessively worn or damaged.
8. Clean all grinding burrs and mounting surfaces before reassembly.
9. Install washer (11) and bushing (10) onto the grinder motor shaft.
10. Install stationary burr (9) inside the grind chamber and secure with two .250" -20 screws (8).

## SERVICE (cont.)

### DC MOTOR AND GRIND CHAMBER - G1MD ONLY (cont.)

11. Install burr (7) on burr auger rotor/spring assembly (6) securing with two .250"-20 screws (5).
12. Slide burr auger rotor/spring assembly and burr (3) onto the motor shaft.
13. Install burr rotor disc (4).
14. Install the adjusting screw w/bearing (19) into the grind selector dial plate (18).
15. Install grind selector dial plate (18) with adjusting screw w/bearing (19) onto the grind chamber housing and secure with two .250"-20 screws (1).
16. Install grind selector knob (17) onto the grind selector dial plate (18).

**NOTE:** Refer to *ADJUSTMENTS* and reset the burrs.

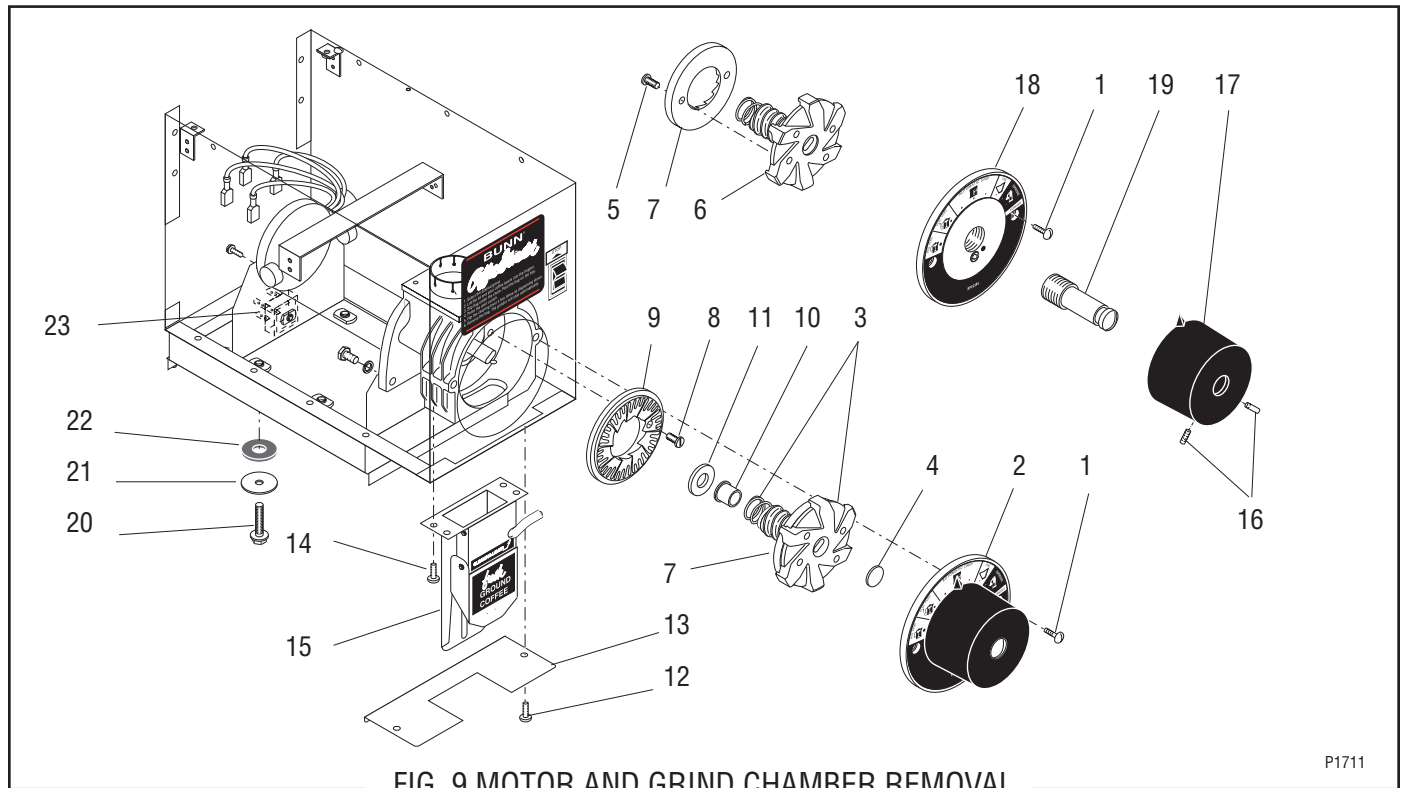

FIG. 9 MOTOR AND GRIND CHAMBER REMOVAL

P1711

## SERVICE (cont.)

### OFF/ON/ START SWITCH

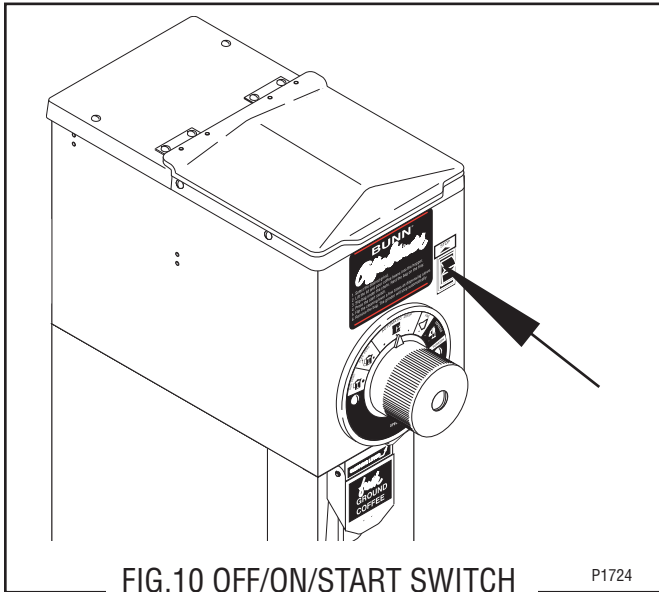

FIG. 10 OFF/ON/START SWITCH

P1724

#### Location:

The Off/On/Start switch is located in the upper front wrapper above and to the right of the grind selector knob (left side when viewed from rear).

#### Test Procedure:

1. Disconnect the grinder from the power source.
2. Check the voltage across the black wire on the Off/On/Start switch and the white wire or the red/black on the relay coil with a voltmeter. Connect the grinder to the power source. The indication must be:
  - a. 120 volts ac for two wire 120 volt models.
  - b. 230 volts ac for two wire 230 volt models.
  - c. 240 volts ac for two wire 240 volt models.
3. Disconnect the grinder from the power source.

If voltage is present as described, proceed to #4.

If voltage is not present as described, refer to the Wiring Diagrams and check the grinder wiring harness.

4. Remove all four wires from the switch.
5. Check for continuity across the two 1/4" terminals when the switch is held in both the "ON" (center) and "START" (lower) positions. Continuity must not be present across these terminals in the "OFF" (upper) position.

If continuity is present as described, proceed to #6.  
If continuity is not present as described, replace the switch.

6. Check for continuity across the two 3/16" terminals when the switch is held in the "START" (lower) position. Continuity must not be present across these terminals in the "OFF" (upper) or "ON" (center) positions.

If continuity is present as described, the Off/On/Start switch is operating properly, reconnect the four wires.

If continuity is not present as described, replace the switch.

#### Removal and Replacement:

1. Remove all wires from the switch terminals.
2. Compress the clips inside the front wrapper and gently push the switch through the opening.
3. Push the new switch into the opening and spread the clips to hold the switch in the hood.
4. Refer to Fig. 11 when reconnecting the wires.

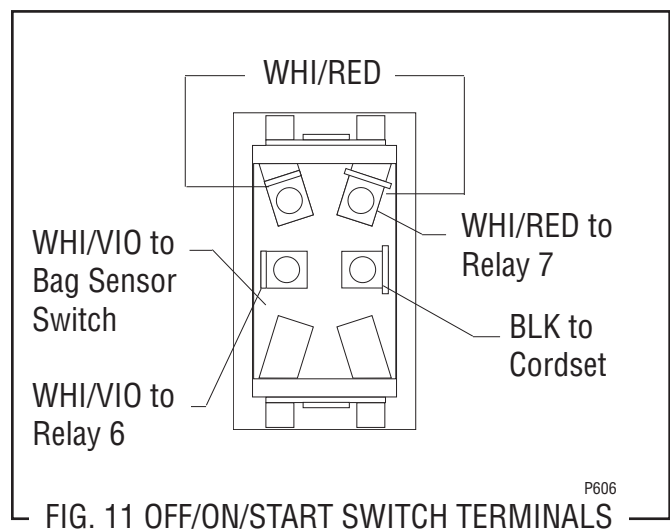

FIG. 11 OFF/ON/START SWITCH TERMINALS

P606



**SERVICE (cont.)**  
**RECTIFIER - G1MD ONLY**

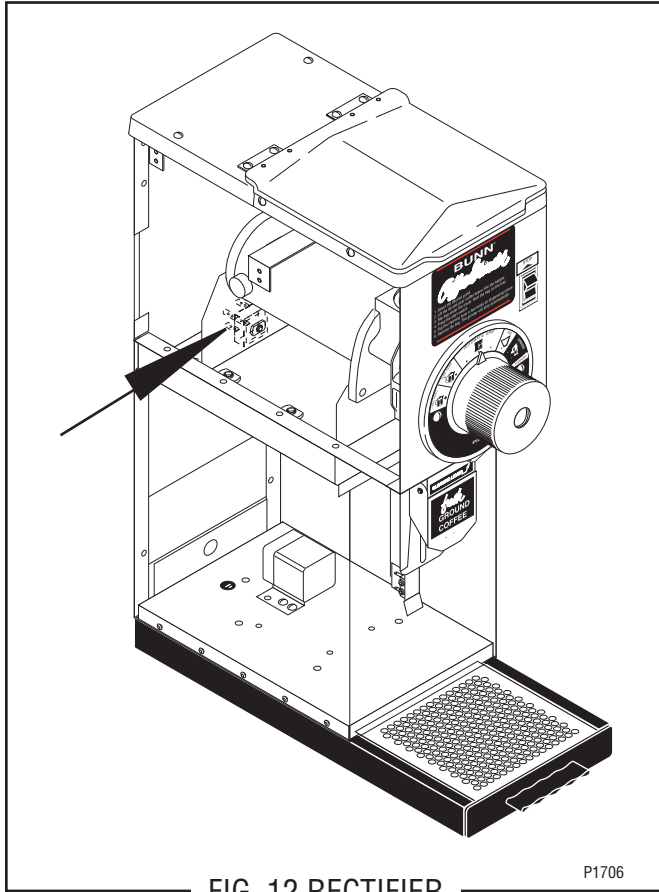

FIG. 12 RECTIFIER

Location:

The rectifier is located inside the grinder housing mounted on the rear of the motor mounting bracket.

Test Procedures:

1. Disconnect the grinder from the power source.
2. Remove the red wire and the black wire from the rectifier.
3. Check the voltage across the (+) and (-) terminals on the rectifier with a voltmeter. Connect the grinder to the power source and start the grinder motor. The indication must be approximately 108 volts dc.
4. Disconnect the grinder from the power source.

If voltage is present as described, the rectifier is operating properly.

If voltage is not present as described, refer to the grinder wiring diagram and check the grinder wiring harness.

Removal and Replacement:

1. Disconnect the wires from the rectifier.
2. Remove the #10-32 screw securing the rectifier to the motor mounting bracket.
3. Remove the rectifier and discard.
4. Install new rectifier on the rear of the motor mounting bracket and secure with a #10-32 screw.
5. Refer to Fig. 13 and reconnect the wires.

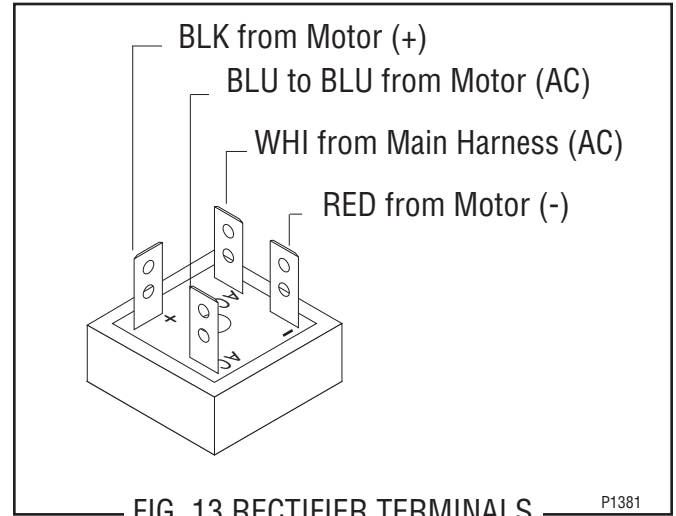
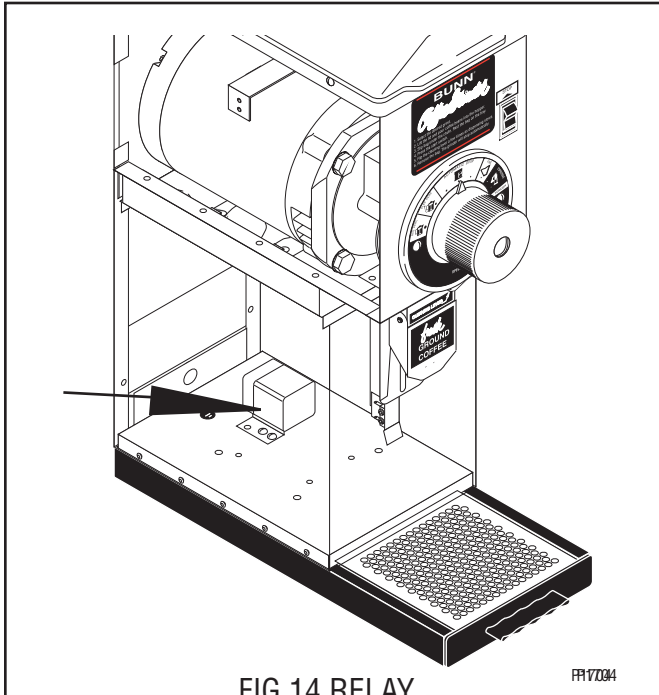

FIG. 13 RECTIFIER TERMINALS

## SERVICE (cont.) RELAY



### Location:

The relay is located on the grinder base inside the lower housing.

### Test Procedure:

1. Disconnect the grinder from the power source and place a coffee bag behind the dispense chute.
2. Check the voltage across the white/orange and white or red/black wires on terminals A & B of the relay with a voltmeter. Hold the Off/On/Start switch in the "START" (lower) position and connect the grinder to the power source. The indication must be:
  - a. 120 volts ac for two wire 120 volt models.
  - b. 230 volts ac for two wire 230 volt models.
  - c. 240 volts ac for two wire 240 volt models
3. Disconnect the grinder from the power source.

If voltage is present as described, proceed to #4.

If voltage is not present as described, refer to the Wiring Diagrams and check the grinder wiring harness.

4. Remove the white/red wires from relay contacts 7 & 9.
5. Check the voltage across the white wire or red/black on terminal B and either white/red wire with a voltmeter. Place the Off/On/Start in either the

"ON" (center) position or "START" (lower) position. Connect the grinder to the power source. The indication must be:

- a. 120 volts ac for two wire 120 volt models.
  - b. 230 volts ac for two wire 230 volt 50 Hz models.
  - c. 240 volts ac for two wire 240 volt 60 Hz models.
6. Disconnect the grinder from the power source.
  7. Check the voltage across terminal B and the remaining white/red wire with a voltmeter. Place the Off/On/Start switch in either the "ON" (center) position or "START" (lower) position. Connect the grinder to the power source. The indication must be:
    - a. 120 volts ac for two wire 120 volt models.
    - b. 230 volts ac for two wire 230 volt 50 Hz models.
    - c. 240 volts ac for two wire 240 volt 60 Hz models.
  8. Disconnect the grinder from the power source.

If voltage is present as described, proceed to #9.

If voltage is not present as described, refer to the Wiring Diagrams and check the grinder wiring harness.

9. Remove the white/violet wire from terminal 6 and white/blue wire from terminal 4.
10. Check for continuity across terminals 7 & 4. Connect the grinder to the power source. Continuity must be present when the Off/On/Start switch is momentarily placed in the "START" (lower) position and a bag is in place behind the coffee dispense chute.
11. Check for continuity across terminals 9 & 6. Connect the grinder to the power source. Continuity must be present when the Off/On/Start switch is momentarily placed in the "START" (lower) position and a bag is in place behind the coffee dispense chute.
12. Disconnect the grinder from the power source.

If continuity is present as described, reconnect the wires, the relay is operating properly.

If continuity is not present as described, replace the relay.

## SERVICE (cont.)

### RELAY (cont.)

#### Removal and Replacement (120 Volt and 240V 60 Hz Models):

1. Remove the wires from the relay terminals.
2. Remove the two #6-32 screws securing the relay bracket w/relay to the grinder base and remove bracket and relay as an assembly.
3. Remove the #6-32 screw securing the relay to the bracket and remove relay and discard.
4. Install new relay to the mounting bracket using one #6-32 screw,
5. Mount the new relay w/bracket to the grinder base using two #6-32 screws.
6. Refer Fig. 15 when reconnecting the wires.

#### Removal and Replacement (230 volt 50 Hz Models):

1. Remove the wires from the relay terminals.
2. Remove the two #6-32 screws securing the relay to the grinder base.
3. Remove relay and discard.
4. Install new relay to the grinder base using two #6-32 screw.
5. Refer Fig. 15 when reconnecting the wires.

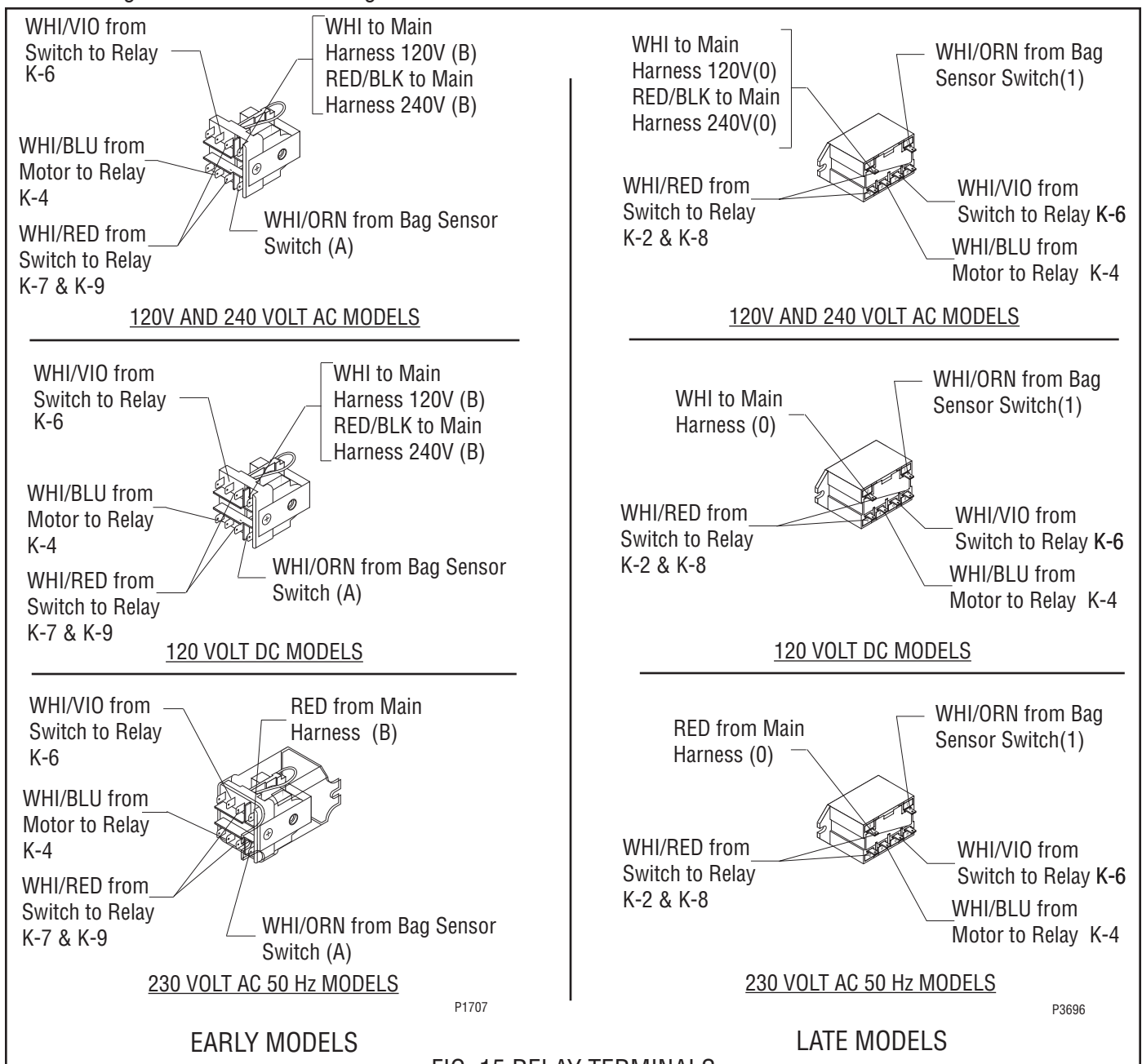
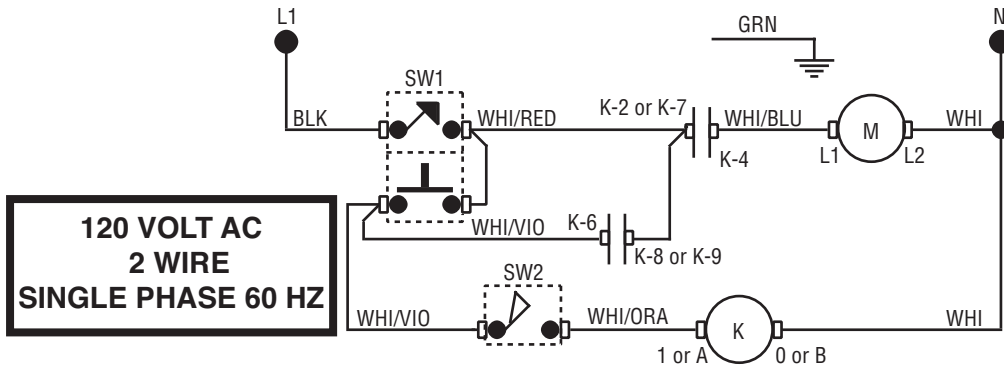
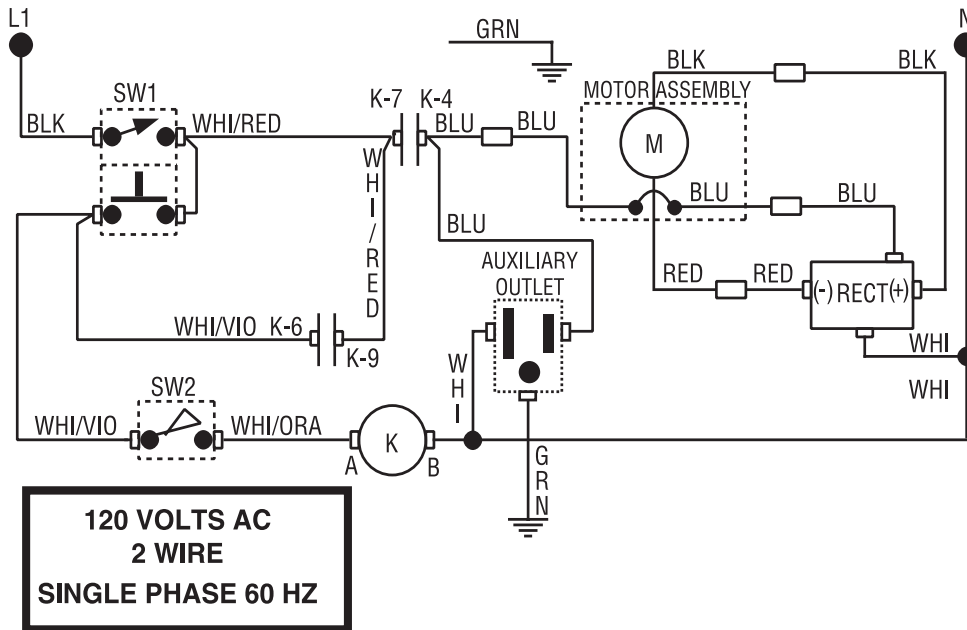

FIG. 15 RELAY TERMINALS

## SCHEMATIC WIRING DIAGRAM G1, G2 & G3



## SCHEMATIC WIRING DIAGRAM G1-MD



## SCHEMATIC WIRING DIAGRAM G1A, G2A & G3A

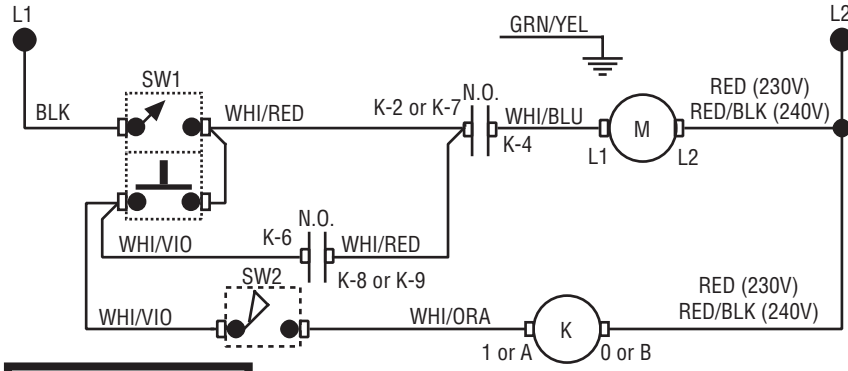

**230 VOLTS AC**  
**240 VOLTS AC**  
**2 WIRE**  
**SINGLE PHASE**