

AUTOMATIC COFFEE URNS

FE75-N FE100-N FE200-N FE300-N
CL75-N CL100-N CL200-N CH75-N CH100-N



FE100-N



FE75-N



Cecilware sells value... Worldwide
Cecilware Corporation

43-05 20th Avenue, Long Island City, NY 11105

Tel: 718-932-1414
800-935-2211

Fax: 718-932-7860

E-Mail: customer.service@cecilware.com

Website: www.cecilware.com



Operation Manual
NN91A 04-2007

ELECTRICAL SPECIFICATIONS

Model No.	Volts	Kilowatts				Amps	
		1 Phase	Heater Element	3 Phase	Heater Element	1 Phase (3) wire	3 Phase (4) wire
FE75-N CL75-N CH75-N	120/240	7	G031A (1)	6	G024A (1)	29	15
	120/208	5.3	G031A (1)	4.5	G024A (1)	26	12
	120/240	8	G013A (1)	8	G026A (1)	34	20
FE100-N CH100-N	120/240	8	G013A (1)	8	G026A (1)	34	20
	120/208	6	G013A (1)	6	G026A (1)	29	17
CL100-N	120/240	7	G031A (1)	8	G026A (1)	29	20
	120/208	5.3	G031A (1)	6	G026A (1)	26	17
CL100-N EXPORT	220	6.7	G013A (1)	-	-	31	-
FE200-N CL200-N	120/240	10	G011A (2)	10	G018A (2)	42	24
	120/208	7.5	G031A (1)	7.5	G018A (2)	38	22
FE300-N	120/240	-	-	15	G011A (3)	-	37
	120/208	-	-	11.3	G011A (3)	-	33

Export Voltages: 220V, 380V, 440V are available.

RECOMMENDED WIRE SIZE FOR FIELD-WIRING URNS

Model No.	Wire Size	
	1 Phase	3 Phase
FE75-N CL75-N CH75-N CL100-N	(2) 10 AWG + GND	(3) 10 AWG + GND
CL100-N EXPORT	(2) 10 AWG + GND	-
FE100-N CH100-N	(2) 8 AWG + GND	(3) 10 AWG + GND
FE200-N CL200-N	(2) 6 AWG + GND	(3) 8 AWG + GND
FE300-N	-	(3) 8 AWG + GND

Neutral and Ground Wires # 14 AWG min.

Note: Field wiring must be suitable for 75° C. Use copper wire only for power supply connections.

GROUNDING: ON ALL URNS, CONNECT A GROUND WIRE TO GROUNDING LUG TO COMPLY WITH LOCAL ELECTRICAL CODES (14 AWG MIN. 75° C)

WARNING LABEL NN85A

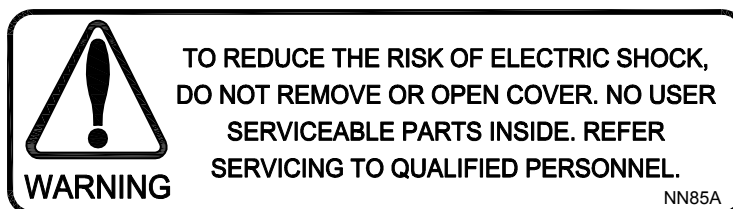

FE75-N Single 3 Gallon Urn, Adjustable By-Pass, Automatic Agitator, and Solid State Timer.

CL75-N Single 3 Gallon Urn, Electro-Mechanical Timer, Adjustable By-Pass, Push-Button Agitator.

CH75-N Single 3 Gallon Urn, Electro-Mechanical Timer, Chinese Hot Tea Urn.

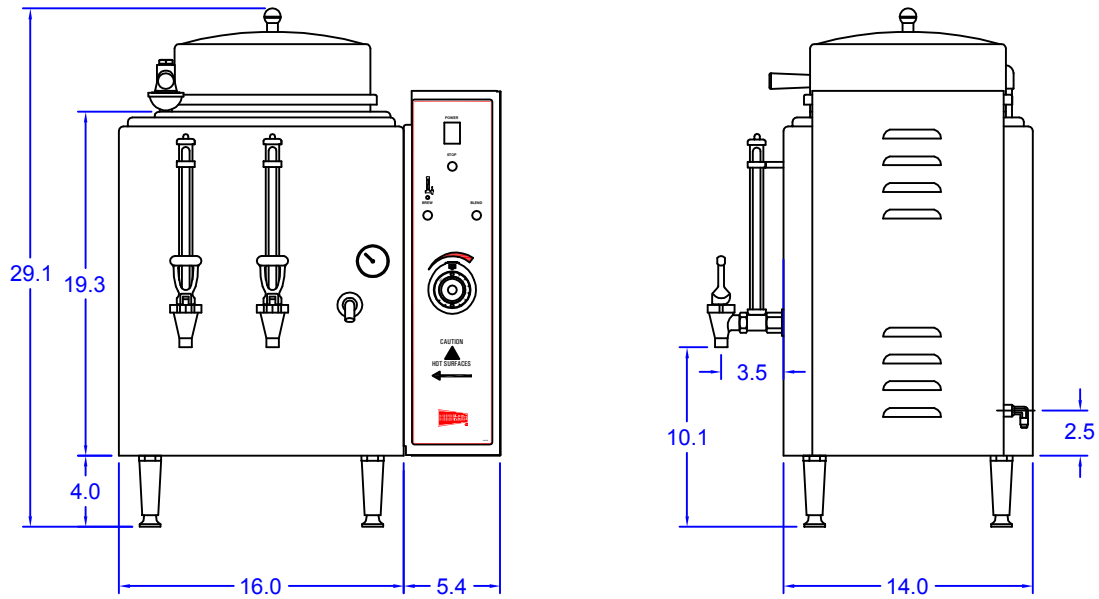

FE100-N Twin 3 Gallon Urn, Adjustable By-Pass, Automatic Agitator, and Solid State Timer.

CL100-N Twin 3 Gallon Urn, Electro-Mechanical Timer, Adjustable By-Pass, Push-Button Agitator.

CH100-N Twin 3 Gallon Urn, Electro-Mechanical Timer, Chinese Hot Tea Urn.

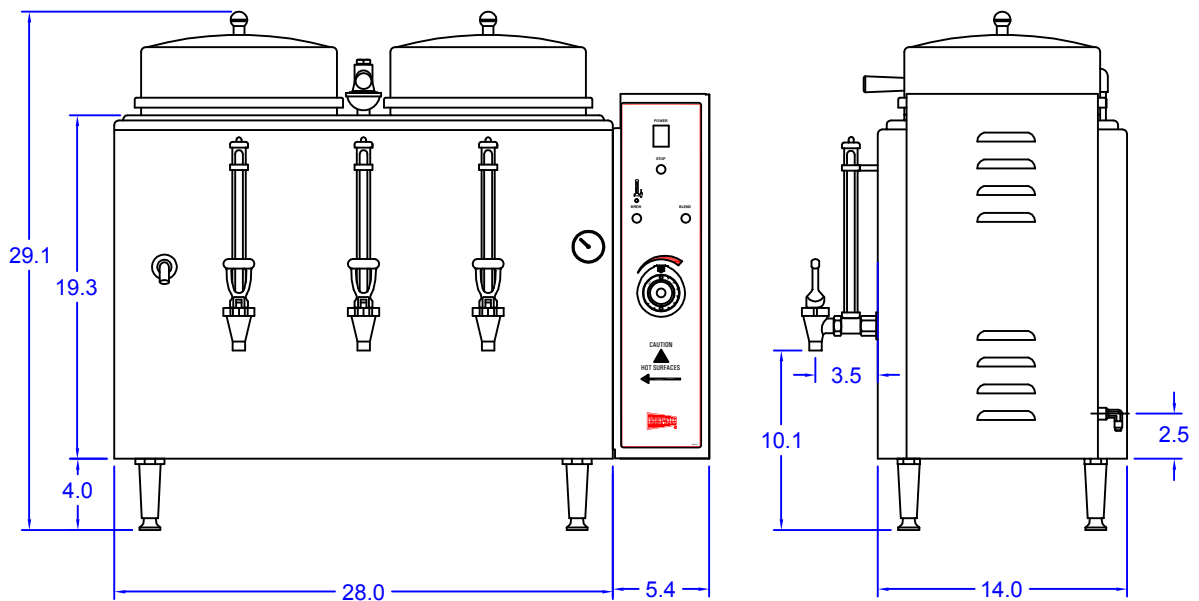

FE200-N Twin 6 Gallon Urn, Adjustable By-Pass, Automatic Agitator, and Solid State Timer.

CL200-N Twin 6 Gallon Urn, Electr-Mechanical Timer, Adjustable By-Pass, Push-Button Agitator.

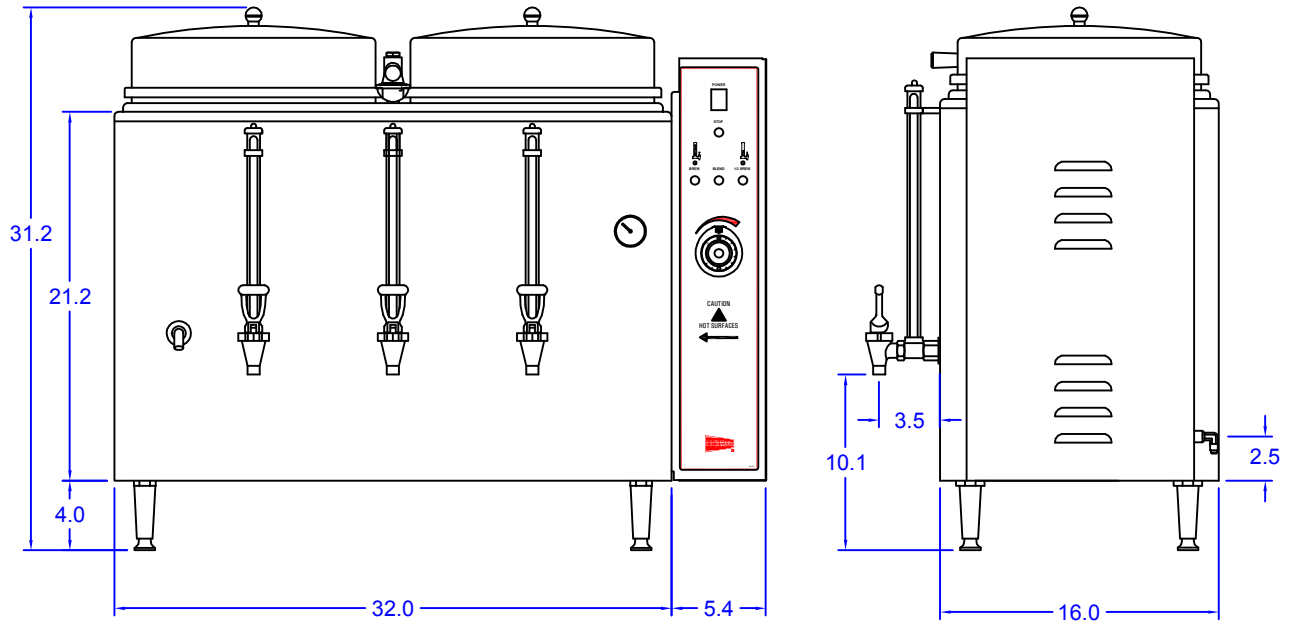

FE300-N Twin 10 Gallon Urn, Adjustable By-Pass, Automatic Agitator, and Solid State Timer.

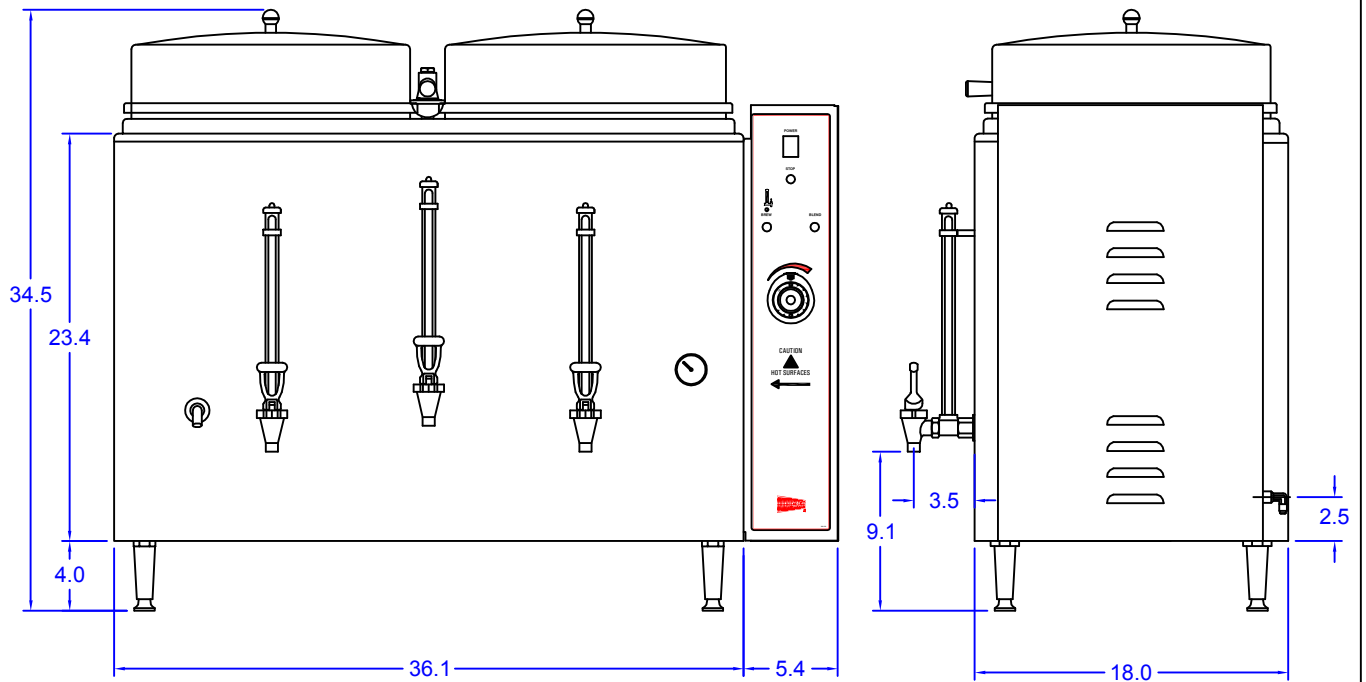

**** UNPACKING AND INSPECTION ****

UNPACKING INSTRUCTIONS: Carefully unpack urn and inspect immediately for shipping damage. Your automatic coffee urn was shipped in a carton designed to give it maximum protection in normal handling. It was thoroughly inspected before leaving the factory and the carrier accepted and signed for it. File any claims for shipping damage or irregularities directly with the carrier, not with the company.

ASSEMBLY: The four legs, faucets, and vent cap drain are packed separately with urn. Install legs by tilting urn on its side and screwing legs into urn leg supports until hand tight. Carefully right unit and install in its permanent location, being sure to leave at least 6" on right side of urn for access to controls. Level urn by adjusting legs. Then attach faucets and install vent cap drain. Cover(s) are shipped with knob(s) on inside to prevent damage. Simply unscrew and reverse knob(s) and hardware. Your urn comes with one brew basket and an introductory filter pack. Additional Cecilware filters are available from your dealer.

**** INSTALLATION INSTRUCTIONS ****

FOR QUALIFIED SERVICE PERSONS ONLY

CAUTION: DO NOT TURN THERMOSTAT ON UNTIL ALL INSTALLATION INSTRUCTIONS HAVE BEEN FOLLOWED.

Water Inlet Connection:

This equipment is to be installed to comply with the applicable Federal, State, or local plumbing codes having jurisdiction. In addition:

1. A quick disconnect water connection or enough extra coiled tubing (at least 2x the depth of the unit) so that the machine can be moved for cleaning underneath.
2. An approved back flow prevention device, such as a double check valve to be installed between the machine and the water supply.

The automatic coffee urn is equipped with a ¼" Flare Water Inlet Fitting which is located on the back of the unit..

HIGHLY RECOMMENDED:

A WATER SHUT-OFF VALVE and A WATER FILTER, preferably a combination Charcoal/ Phosphate Filter, to remove odors and inhibit lime and scale build up in the machine.

Note: In areas with extremely hard water, a water softener must be installed in order to prevent a malfunctioning of the equipment and in order not to void the warranty.

TO PRIME:

CAUTION: THERMOSTAT MUST BE IN THE "OFF" position. Turn on water supply and electrical power to urn and wait until water is visible in center gauge glass (left-hand gauge glass on 3-gallon single urns). Then turn thermostat knob to 10; thermostat pilot light shows heater is on. Urn jacket will continue to fill automatically until water reaches the proper level. When indicator on dial thermometer approaches the "W" in BREW zone, 197°-203°F (92°-95°C), urn is ready to brew coffee. In high altitude locations (at least 5000 ft, above sea level), thermostat may have to be lowered to prevent boiling.

NOTE: FOLLOW THE ABOVE INSTRUCTIONS FOR INITIAL PRIMING AND AFTER DRAINING URN FOR SERVICING.

**** CORRECT PROCEDURES FOR BREWING COFFEE AS RECOMMENDED BY THE COFFEE BREWING CENTER ****

1. Use fresh urn grind or drip grind coffee . . . spread evenly on filter for proper extraction.
2. Urn should be connected to cold water supply and water heated to 197°-203°F (92°-95°C) before brewing coffee.
3. While brewing, leave cover on urn to preserve aroma and prevent excessive steaming. Total contact time for urn grind should be approximately 4-6 minutes.
4. Remove grounds and filter as soon as coffee has dripped through. Never pour coffee back through spent grounds.
- 5a. Urns with automatic agitator (FE series), blend coffee automatically at end of brewing cycle. Press and hold agitator ON switch for additional blending.
- 5b. If urn has a manual agitator (CL series), press and hold agitator ON switch for 15 seconds after brewing cycle to blend coffee.
- 5c. Hold coffee at 185°-190°F (85°-88°C) (about 8 on thermostat.) Brewed coffee should not be held for longer than one (1) hour and should never be reheated.

AUTOMATIC COFFEE URNS

FE SERIES

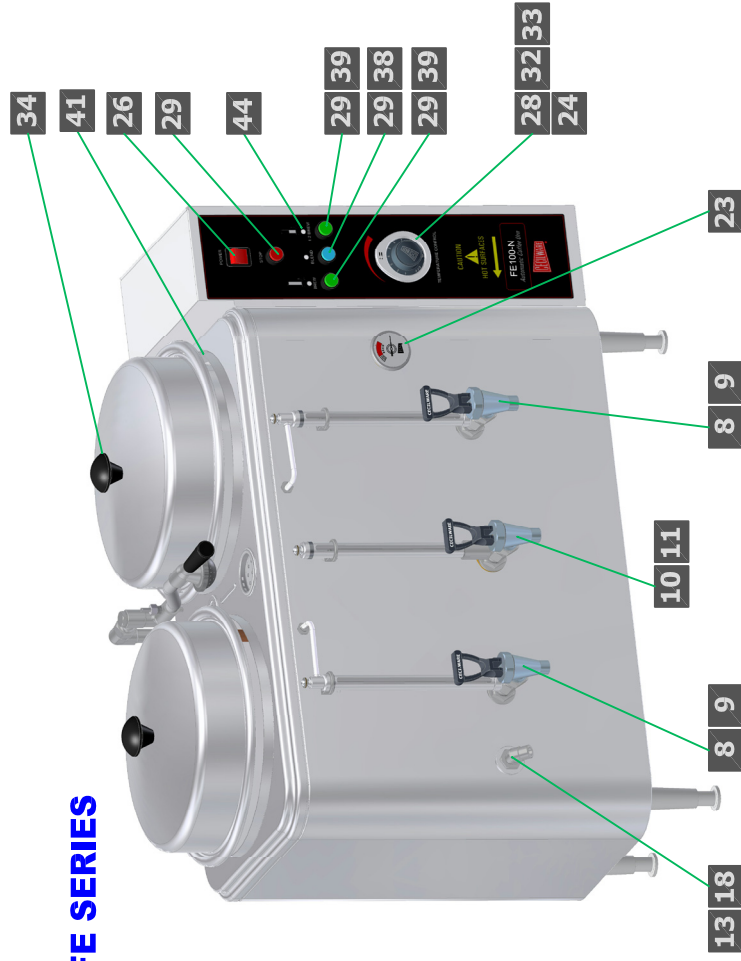

CL & CH SERIES

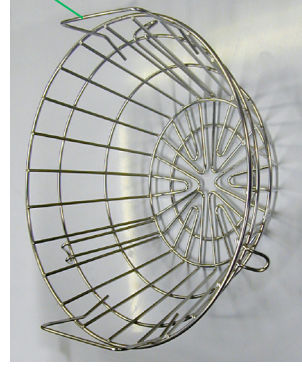
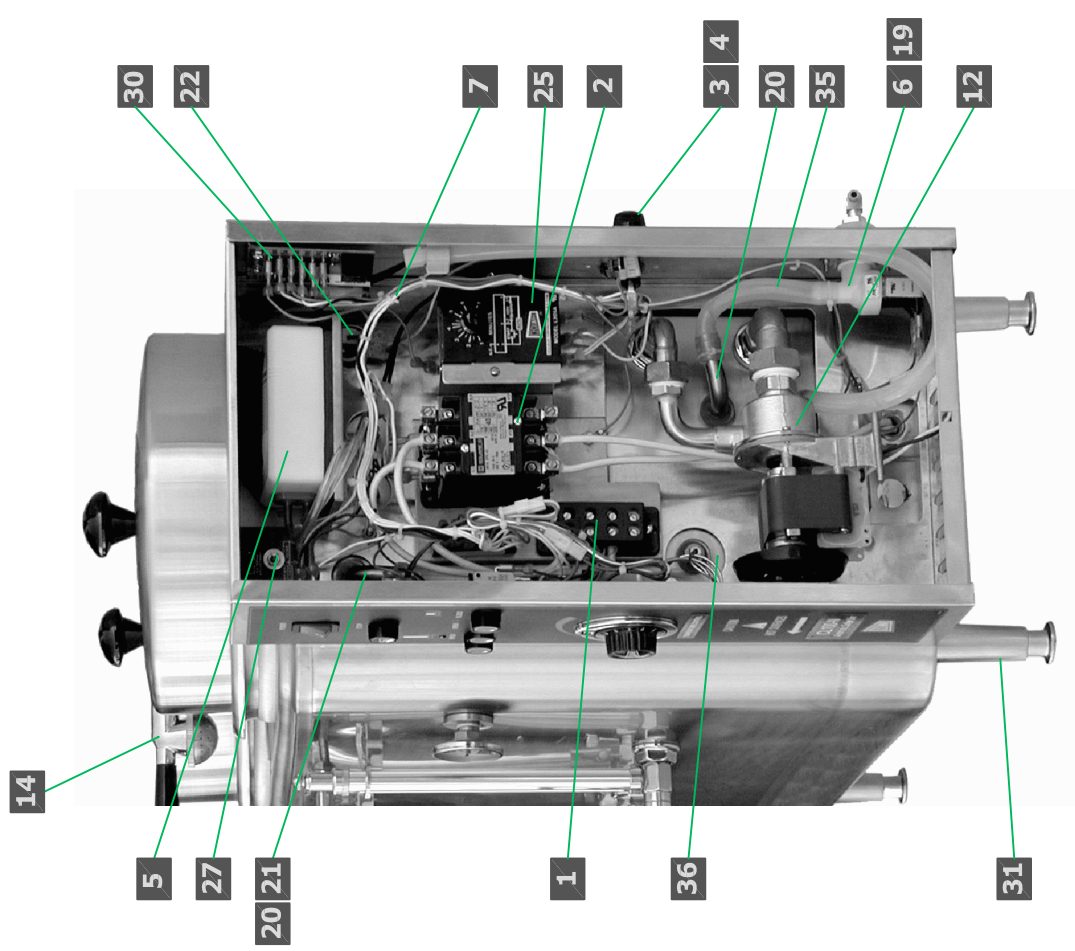

AUTOMATIC COFFEE URNS

SPRAY ARM ASSEMBLY

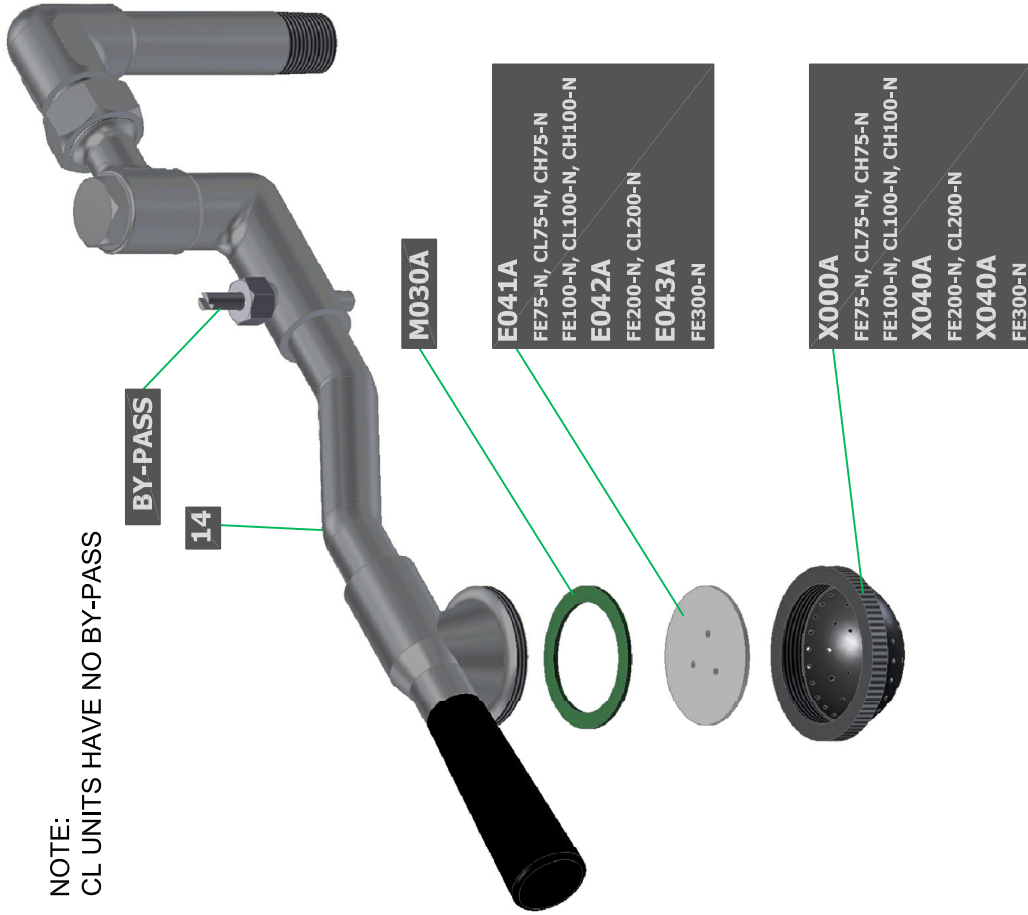

FAUCET, COFFEE

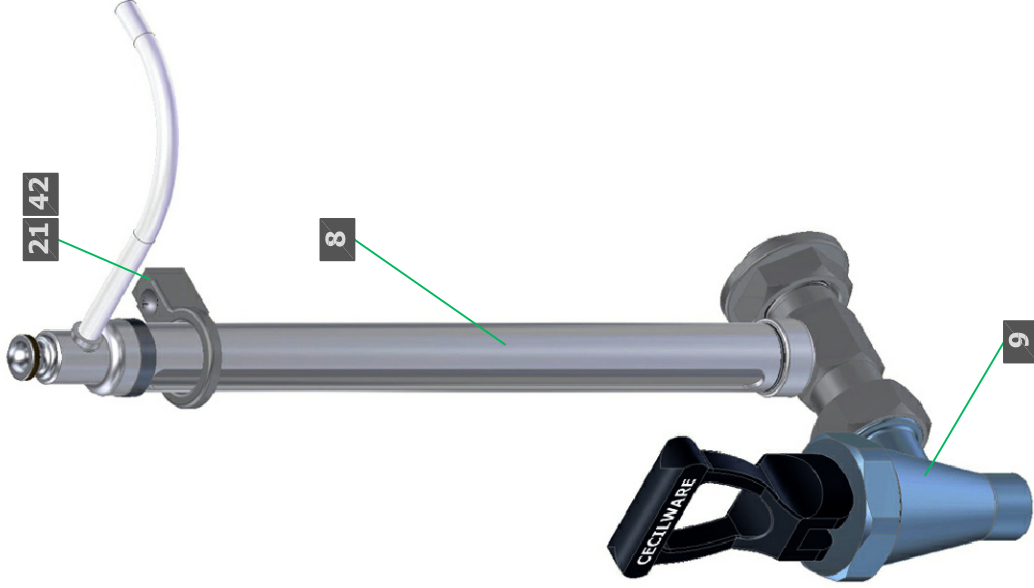

FAUCET, HOT WATER

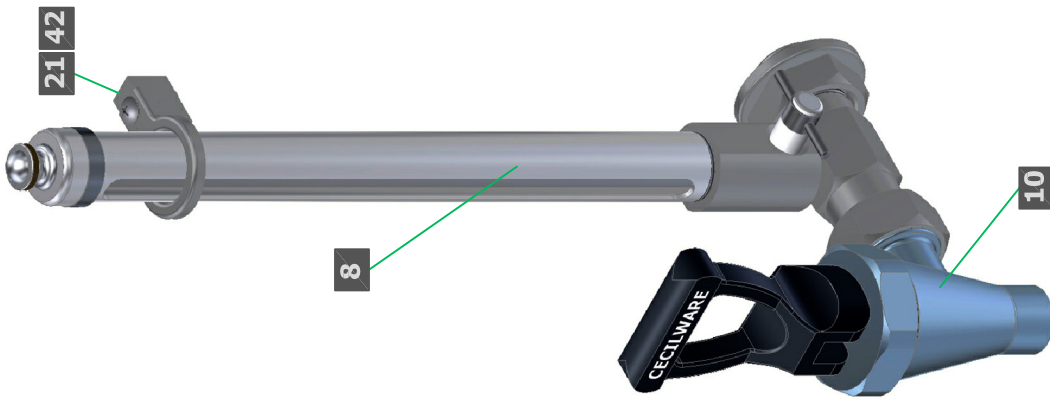

To prevent lime buildup, especially in hard water areas, remove and clean spray head cap and spray head disc frequently. To clean swivel valve, loosen nut and remove spray arm assembly from urn.

Remove sediment by inserting a pipe cleaner through small hole in valve.

If maximum setting of timer fails to deliver enough water, check water pump.

PARTS LIST - FE-N SERIES AUTOMATIC COFFEE URNS

ITEM	PART #	DESCRIPTION	QUANTITY										
			FE75-N	FE75-N DUAL BREW	CL75-N	CH75-N	FE100-N	FE100-N DUAL BREW	CL100-N	CH100-N	FE200-N DUAL BREW	CL200-N	FE300-N
1	B157A	TERMINAL BLOCK 4 WIRE	1	1	1	1	1	1	1	1	1	1	1
2	C036A	CONTACTOR, 3 POLE, 50 AMP - (240V)											
2	CG12A	CONTACTOR, 3 POLE, 50 AMP - 120V	1	1	1	1	1	1	1	1	1	1	1
3	C395A	FUSE 6A SC-6	1	1	1	1	1	1	1	1	1	1	1
4	C396A	FUSEHOLDER, SC-6	1	1	1	1	1	1	1	1	1	1	1
5	C511A	AIR PUMP, AGITATOR (120V ONLY)	1	1	1		1	1	1		1	1	1
5	C512A	AIR PUMP, AGITATOR (220V)											
6	CD417	WATER INLET VALVE (120V ONLY)	1	1	1	1	1	1	1	1	1	1	1
6	CD418	WATER INLET VALVE (240V)											
7	CH362	WIRING HARNESS, DUAL BREW	1	1			1	1			1		1
7	CH387	WIRING HARNESS (MECH. TIMER)			1	1			1	1		1	
8	D001B	SIGHT GLASS ASSEMBLY (COFFEE)	1	1	1	1	2	2	2	2			
8	D020B	SIGHT GLASS ASSEMBLY (COFFEE)									3	3	
8	D031B	SIGHT GLASS ASSEMBLY (COFFEE)											2
9	D017Q	FAUCET, SHANK ASSEMBLY (COFFEE)	1	1	1	1	2	2	2	2	2	2	2
10	D022Q	FAUCET, SHANK, VALVE ASSEMBLY (WATER)	1	1	1	1	1	1	1	1	1	1	1
11	D024A	SIGHT GLASS ASSEMBLY (WATER)	1	1	1	1	1	1	1	1			
11	D032A	SIGHT GLASS ASSEMBLY (WATER)											1
12	E000A	WATER PUMP (120V ONLY)	1	1	1	1	1	1	1	1	1	1	1
12	E070A	WATER PUMP (240V)											
13	E009A	OVERFLOW FITTING W/ NUT	1	1	1	1	1	1	1	1	1	1	1
14	E039Q	COMPLETE SPRAY ARM ASSY W/ BYPASS											1
14	E045Q	COMPLETE SPRAY ARM ASSY W/ BYPASS	1	1	1	1	1	1	1	1			
14	EO55Q	COMPLETE SPRAY ARM ASSY W/ BYPASS									1	1	
15	G011A	HEATER ELEMENT 5KW 240V 1PH									2	2	3
16	G013A	HEATER ELEMENT 8KW 240V 1PH					1	1					
17	G031A	HEATER ELEMENT 7KW 240V 1PH	1	1	1	1			1	1			
18	H429Q	TUBE, OVERFLOW	1	1	1	1	1	1	1	1			
19	K491B	HOSE NUT ASSEMBLY (BRITISH THREAD)	1	1	1	1	1	1	1	1	1	1	1
20	H416A	WATER INLET TUBE	1	1	1	1	1	1	1	1	1	1	1
21	K808A	RETAINER MOUNTING BLOCK	2	2	2	2	3	3	3	3	3	3	3
22	K810Q	LEVEL SENSOR, DUAL PROBE	1	1	1	1	1	1	1	1	1	1	1
23	L007A	THERMOMETER, BREW DIAL	1	1	1	1	1	1	1	1	1	1	1
24	L154A	TIMER, MECHANICAL (0 - 15 MINUTES)			1	1			1	1		1	
25	L205A	TIMER, SINGLE (120V/ 240V)	1				1						1
25	L774A	TEACH-ME TIMER, SINGLE	1				1						1
25	L214A	TIMER, DUAL (120V/ 240V)		1				1			1		
25	L752A	TEACH-ME TIMER, DUAL		1				1			1		
26	L155A	ROCKER SWITCH, POWER ON-OFF	1	1	1	1	1	1	1	1	1	1	1
27	L238A	DELAY TIMER-SOLID STATE (USED ON BOTH 120V & 240V)	1	1	1	1	1	1	1	1	1	1	1
28	L532A	THERMOSTAT 25A, 250V MT 190°F	1	1	1	1	1	1	1	1	1	1	1
29	L584A	SWITCH, PUSHBUTTON	3	4			3	4			4		3
30	L775A	DUAL LEVEL CONTROL HI-LO (120V)	1	1	1	1	1	1	1	1	1	1	1
30	L776A	DUAL LEVEL CONTROL HI-LO (220V ONLY)											
31	M005S	LEGS (4" ADJ) (4 PER BAG)	1	1	1	1	1	1	1	1	1	1	1
32	M008A	KNOB THERMOSTAT	1	1	1	1	1	1	1	1	1	1	1
33	M016A	THERMOSTAT BEZEL	1	1	1	1	1	1	1	1	1	1	1
34	M027A	KNOB, URN COVER	1	1	1	1	2	2	2	2	2	2	2
35	M326A	WATER INLET HOSE 3/8 x 5/8 x 8" (IN FEET)	1	1	1	1	1	1	1	1	1	1	1
36	M461A	SILICONE GROMMET 12mm	3	3	3	3	3	3	3	3	3	3	3
37	M462A	SILICONE GROMMET 15mm											
38	M876A	BLUE BUTTON (BLEND)	1	1	1		1	1	1		1	1	1
39	M877A	GREEN BUTTON (BREW)	2	2			2	2			2		2
40	MA15A	COPPER GASKET, TEFLON FILLED	6	6	6	6	7	7	7	7	7	7	7
41	Q027Q	LINER ASSY & COVER (FE75/ FE100)	1	1	1	1	2	2	2	2			
41	Q094Q	LINER (FE300)											2
41	Q204Q	LINER ASSY & COVER (FE200)									2	2	
42	UB17A	SIGHT GLASS RETAINER	2	2	2	2	3	3	3	3	3	3	3
43	V002A	BREW BASKET, FE75/ FE100	1	1	1	1	1	1	1				
43	V003A	BREW BASKET, FE200									1	1	
43	V081A	BREW BASKET, FE300											1
44	32004	INDICATOR LIGHT W/ RED LENS	2	3			2	3			3		2

COMPONENT TESTS

A) Thermostat Adjustments:

The Thermostat is factory set for proper dispense temperature of 200°F ± 3°F with the control knob set to the maximum clockwise position. If field adjustments are needed proceed as follows:

To DECREASE temperature, turn the control knob slightly in the COUNTERCLOCKWISE direction.

For qualified technicians ONLY:

1. To INCREASE the water temperature - With the Thermostat Knob to its maximum clockwise position, remove the knob and locate the slotted adjustment screw inside the hollow thermostat shaft. Using a narrow-bladed screwdriver, engage slotted adjustment screw and turn it ¼ turn slowly counter-clockwise. Allow a few minutes for the temperature to reach set level. The Heater Light will go ON, indicating the heating element is activated, wait for it to go OFF, indicating that the water has reached new set temperature. Take a temperature reading and repeat if necessary.

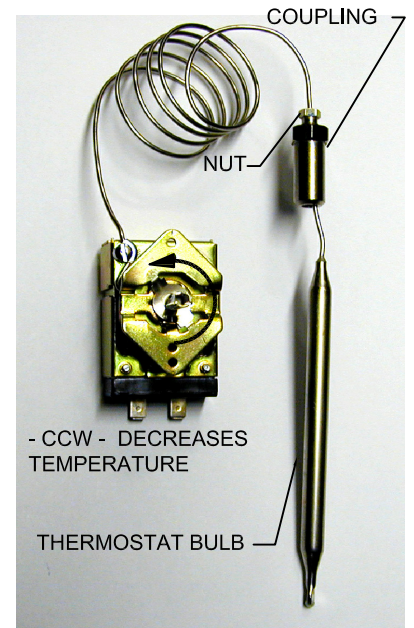

B) Water Inlet Valve Test

Turn power OFF. If the water level rises inside a partially filled tank, the Water Inlet Valve is leaking. Disconnect wires from the Water Inlet Valve coil and connect a 2 wire line cord to the terminals. Plug it into a 115V outlet. If water flows in and stops when you pull it out, the Valve is working fine. Repeat this test a few times. The problem may be in the Probe or Water Level Control Board. If the water does not flow in when the cord is plugged into an electrical outlet, the Solenoid coil may be damaged, opened or the valve may have an obstruction preventing the water from flowing in. Clean or replace it.

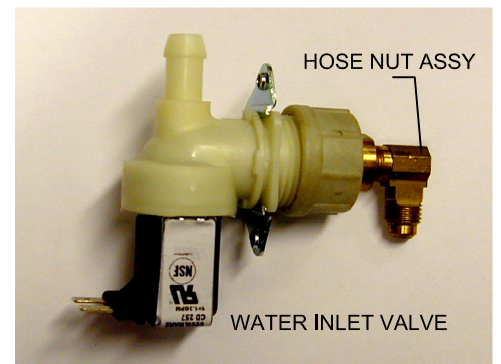

C) Dual Probe Test

If lack of water persists, check the probe as follows:

Turn on the power and water supply. Check inside the tank to make sure the water is below the Probe. Pull the BLUE wire and terminal OFF the Probe rod. If water still does not flow after the wire is disconnected from the Probe, the problem may be in the Solid State Dual Level Control Board.

If water starts flowing into the tank, the Probe may be grounded, due to excessive liming. Check with Ohm meter. Clean or replace probe.

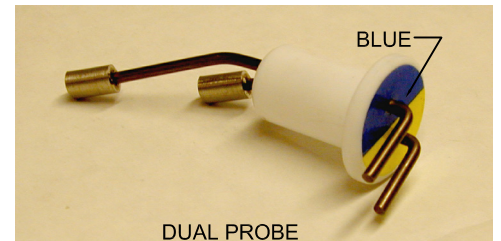

D) Dual Probe Liquid Level Controller Test

Check the Controller as follows:

1. Make sure there is power input to the Controller at the terminals AC1 & AC2

Your voltmeter should read 115 Volts. It should read the same at terminals AC1 & FILL when the water level is low. This is the output power to actuate the coil of the Solenoid Valve to open it. The lack of voltage at terminals AC1 & L-LEVEL or H-LEVEL indicates that the Controller is not working properly.

2. Make sure all wire connections are tight, including ground.

3. If after this, the Controller is still failing to open the Water Inlet Valve, replace it.

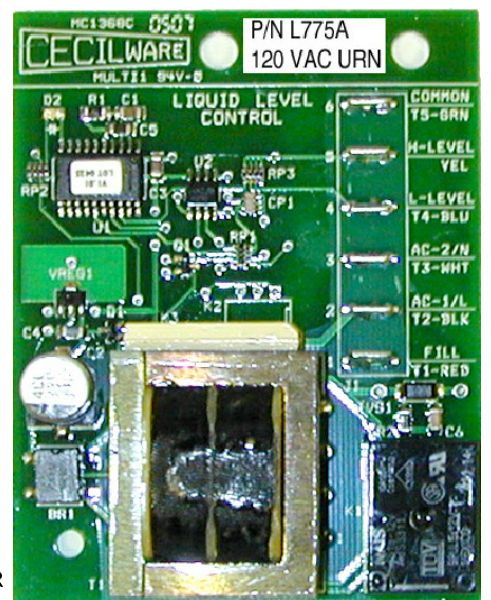

DUAL PROBE CONTROLLER

SOLID-STATE TIMER ADJUSTMENT: A factory pre-set electronic solid-state timer controls the volume of water for each brew cycle. If more or less water is desired, follow these instructions:

Turn knob of timer clockwise to increase volume of water or counterclockwise to decrease it. Run through a complete brew cycle after each adjustment. Since timer cannot be readjusted in mid-cycle, simply push cycle stop switch at bottom right of side box if water gets too high. If maximum setting of timer fails to deliver enough water, check water pump and spray head and follow instructions under maintenance.

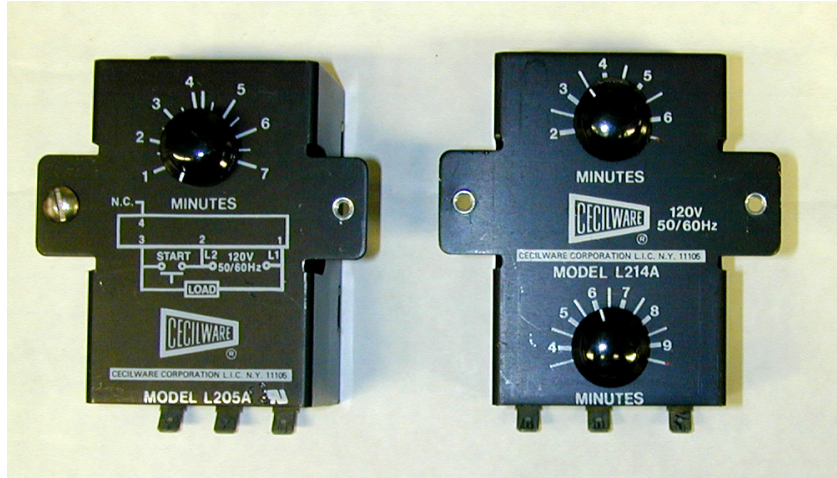

SINGLE TIMER
L205A

DUAL TIMER
L214A

MECHANICAL TIMER ADJUSTMENT (ALL CL's & CH's): The factory pre-set mechanical timer can be adjusted for more or less water by following these instructions:

Remove timer knob and loosen lock nut holding stop pin. To increase volume of water, rotate stop pin clockwise. To decrease, rotate counterclockwise. Tighten lock nut and replace knob.

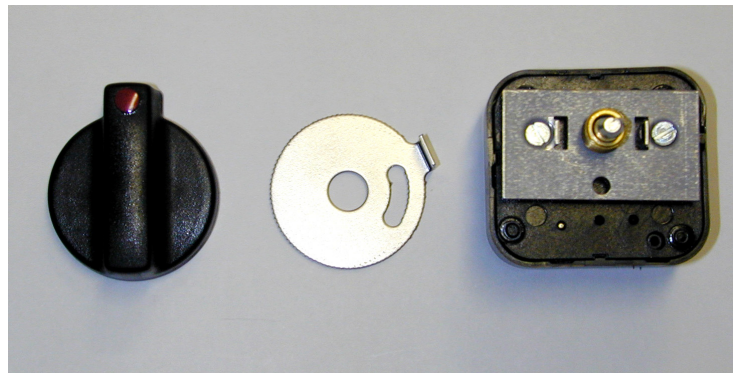

MANUAL TIMER
L154A

SPRAY ARM BY-PASS ADJUSTMENT (ALL Urns): Adjustable bypass allows proper brew extraction even with variations caused by soft or treated water. If bypass requires adjustment to correct for local water conditions, proceed as follows: Position spray head over center of coffee liner and press BREW switch. Turn by-pass adjustment screw clockwise to decrease by-pass flow (for stronger coffee) or counter-clockwise to increase by-pass flow (for weaker coffee). At end of brewing cycle, note volume of water in coffee liner. Readjust timer if necessary to obtain the correct volume of water.

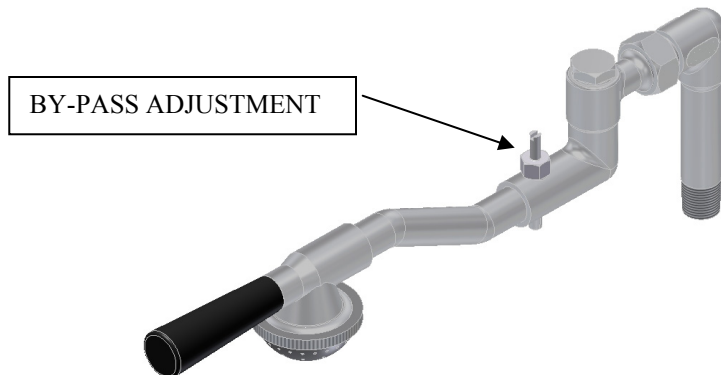

THERMOSTAT ADJUSTMENT: To adjust temperature of water in urn jacket 197°-203°F (92-95°C), turn thermostat knob to 10 (maximum clockwise position). Pull off knob and insert a small screwdriver into adjusting screw in center of shaft when temperature on dial thermometer approaches the "W" in the word BREW. Slowly rotate screw clockwise until thermostat pilot light goes out. Turning screw clockwise lowers temperature and turning counter-clockwise raises it. Apply a sealer (glyptol or fingernail polish) to screw after adjustment has been made.

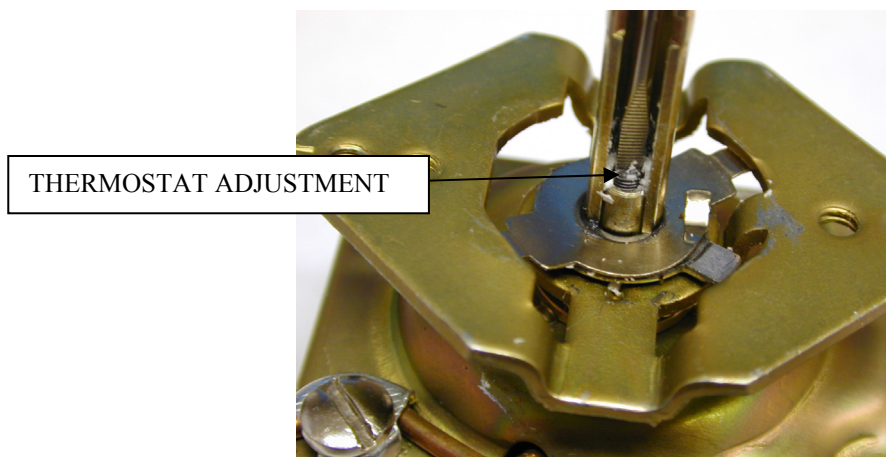

**** MAINTENANCE TIPS ****

SPRAY ARM ASSEMBLY: The new improved spray head system was designed to facilitate easier cleaning and maintenance. The swivel valve has a larger flow opening and the spray head cap is equipped with a stainless steel disc, used to control the flow of water.

When ordering replacement parts, be sure to order the correct disc and spray cap for each urn, as shown in Illustration.

To prevent lime buildup, especially in hard water areas, remove and clean spray head cap and spray head disc frequently. To clean swivel valve loosen nut and remove spray arm assembly from urn. Remove sediment by inserting a pipe cleaner through small hole in valve. If maximum setting of timer fails to deliver enough water, check water pump.

CAUTION: DISCONNECT POWER BEFORE ATTEMPTING ANY ELECTRICAL REPAIRS.

IF WATER FAILS TO HEAT:

1. Check line fuse or circuit breaker. Replace or reset if necessary.
2. Make sure thermostat is in ON position. If thermostat pilot light does not come on, replace thermostat. (Refer to instructions below.) If pilot light is on, measure continuity between terminals 1 and 2 of thermostat, and between terminals 3 and 4. If a resistance is measured, replace thermostat.
3. If thermostat is okay, check wiring and repair if necessary: if wiring is okay, check heater resistance; if high or infinite, replace as follows:

REPLACING HEATER:

1. Shut off power and disconnect water supply at elbow. Drain urn.
2. Remove one coffee gauge glass, faucet, shank, and liner.
3. Tilt urn and disconnect wires to heater.
4. Remove socket head screw and heater flange and lift heater out.
5. Install new heater and reassemble urn.
6. Repeat priming instructions on page 2. **CAUTION:** DO NOT TURN ON THERMOSTAT UNTIL URN IS PRIMED.

REPLACING THERMOSTAT (All Models):

Thermostat is located in side box of urn. Lift off side box door to gain access to thermostat; then follow instructions above.

1. Shut off power, disconnect water supply, and drain urn by opening hot water faucet. When faucet stops running you are ready to remove the thermostat bulb.
2. Remove thermostat knob and two screws holding thermostat in place.
3. Disconnect wires from thermostat.
4. Pull out thermostat bulb.
5. Install new thermostat, push in the new thermostat bulb. Tighten compression nut on thermostat fitting to prevent leaking
6. Repeat priming instructions. **CAUTION:** DO NOT TURN ON THERMOSTAT UNTIL URN IS PRIMED.

IF WATER FROM COLD WATER SUPPLY LINE DOES NOT ENTER URN:

1. Check water supply to external shut-off valve.
2. Check fuse on rear of side box and replace if necessary.
3. If water supply and fuse are okay, remove fuse and lift off side box door. exposing terminal block and electrical wiring.
4. Check dual probe liquid level controller. (see component tests)

REPLACING SOLENOID:

1. Shut off water supply, remove fuse, and lift off side box door.
2. Disconnect wires from solenoid: then remove flare nut and unscrew solenoid valve from bracket.
3. Install new solenoid and reinstall fuse and side box door.
4. If necessary, follow priming instructions.

IF WATER RUNS OUT AT OVERFLOW DRAIN:

1. Make sure urn is level and overflow tube is vertical.

2. Remove fuse from rear of side box.
3. If water continues to flow, solenoid valve is dirty or not seating properly. Replace solenoid as described above.

NO WATER FROM SPRAY HEAD:

1. Check fuse first.
- 2a. For all urns except CL's: Depress BREW switch and release. If switch remains lit, water pump is probably not operating. Lift off side box door and check if fan on water pump is rotating. If not, replace pump as described below.
- 2b. For CL urns: Turn brew timer knob clockwise. Replace timer if it does not go on. If timer goes on but pump doesn't, replace pump.

REPLACING WATER PUMP:

1. Shut off water supply and remove fuse. Drain urn to level of water faucet.
2. Lift off side box door and disconnect the two pump wires.
3. Loosen union fittings on pump and remove pump from urn (Refer to page 15, Installation & Removal of Water Pump.)
4. Replace pump and follow priming instructions on page 2.

CHECKING SOLID-STATE TIMER (ALL URNS EXCEPT CL's): Press and hold BREW switch for 10 seconds. Brew cycle should start. If water stops coming from spray head as soon as BREW switch is released, timer is not operating. Replace it. (Instructions below.) If no water comes from spray head when BREW switch is pressed, replace switch.

NOTE: To check mechanical timer on CL urns, refer to NO WATER FROM SPRAY HEAD.

REPLACING SOLID-STATE TIMER:

1. Remove fuse, lift off side box door, and remove timer from bracket.
2. Carefully note locations of colored wires on timer board, then remove wires.
3. Replace timer and reassemble unit in reverse order.

BLENDING - AUTOMATIC TYPE (ALL FE):

OPERATION:

The agitator pump circuit is programmed to operate immediately after brewing cycle. The circuit pumps air through the coffee gauge glass(es) into the coffee liner(s). The complete cycle takes about 20 seconds. For additional blending, simply press the BLEND switch.

MAINTENANCE:

If agitation is not sufficient to blend coffee, check flexible tubing, and glasses and fittings, for possible air leaks. Replace as necessary.

If agitator pump does not operate immediately after brewing cycle or when BLEND switch is pressed, replace agitator pump or solid state agitator timer.

If agitator pump comes on immediately after brewing cycle, but does not operate when BLEND switch is pressed, replace BLEND switch.

BLENDING - MANUAL TYPE (CL URNS):

OPERATION:

Immediately after brewing cycle, depress BLEND switch and hold for about 20 seconds. Your coffee will be completely blended and ready to serve.

MAINTENANCE:

If agitator pump does not operate when BLEND switch is pressed, replace switch, if pump still does not operate, replace pump.



AUTOMATIC URNS - CLEANING INSTRUCTIONS



Cleaning the Cecilware Automatic Coffee Urn....

To ensure the highest quality, best tasting coffee, your urn must be cleaned daily after the last batch. Regular cleaning and preventive maintenance is essential in keeping your coffee urn looking and working like new.

CAUTION - Do not use cleansers, bleach liquids, powders or any other substance containing chlorine. These products promote corrosion and will pit the stainless steel. **USE OF THESE PRODUCTS WILL VOID THE WARRANTY.**

DAILY CLEANING INSTRUCTIONS

WARNING - These steps involve working with very hot water.

1. Drain the urn; then run a brew cycle of hot water. After spraying hot water into the liner, thoroughly brush the liner with a long handled brush.
2. Drain the water and repeat step one. Run another brew cycle. Brush the liner and drain.
3. Wash the wire brew baskets with urn cleaner and rinse thoroughly.

WEEKLY CLEANING INSTRUCTIONS

WARNING - These steps involve working with very hot water.

Coffee urns must have a special scouring once a week. To scour the urn:

1. Be sure urn is full of water at max. brewing temperature.
2. Fill the liner with several gallons of water and, depending on urn size, add at least 1 1/2 to 3 ounces of coffee urn cleaning compound. Set the thermostat to high (NO. 10), then run a brew cycle of hot water.
3. Allow solution to remain in the liner for approximately 30 minutes.
4. Scrub the inside of both the liner and the cover with a long handled brush.
5. Drain the cleaning solution from the liner. Rinse by running several brew cycles with the sprayhead centered over the liner. Be sure to drain the rinse water between cycles.
6. Thoroughly clean the faucets.

WARNING - Never remove the faucet when the liner has water or coffee in it. Switch OFF the power to the unit at the circuit breaker. Turn off the water line running to the urn.

Use a long, thin gauge glass brush to clean the coffee gauge glass. Use the same brush to clean the fitting at the bottom of the liner and the pipe connected to the coffee faucet.

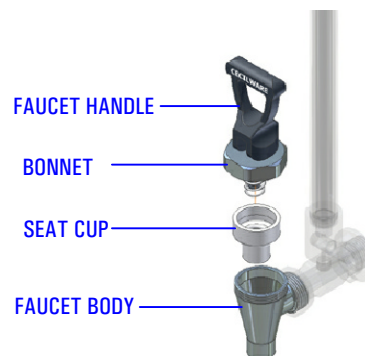

Website: www.cecilware.com

INSTALLATION & REMOVAL OF WATER PUMP



ALWAYS USE A COUNTER WRENCH WHEN INSTALLING OR
REMOVING PUMP TO AVOID DAMAGING COPPER TUBING.
DO NOT OVERTIGHTEN.

FE-N SERIES W/ SINGLE TIMER

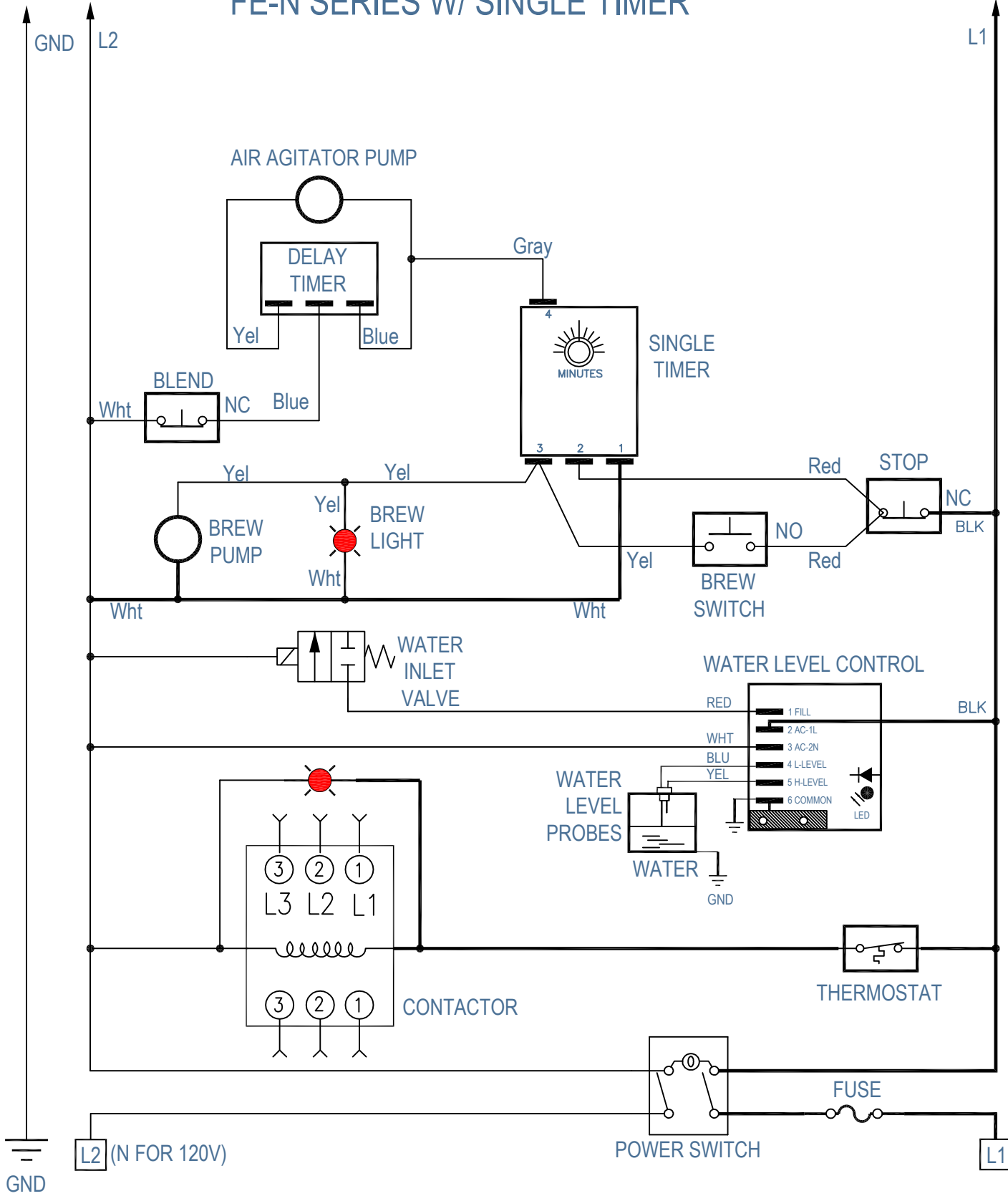

FE-N SERIES W/ DUAL TIMER

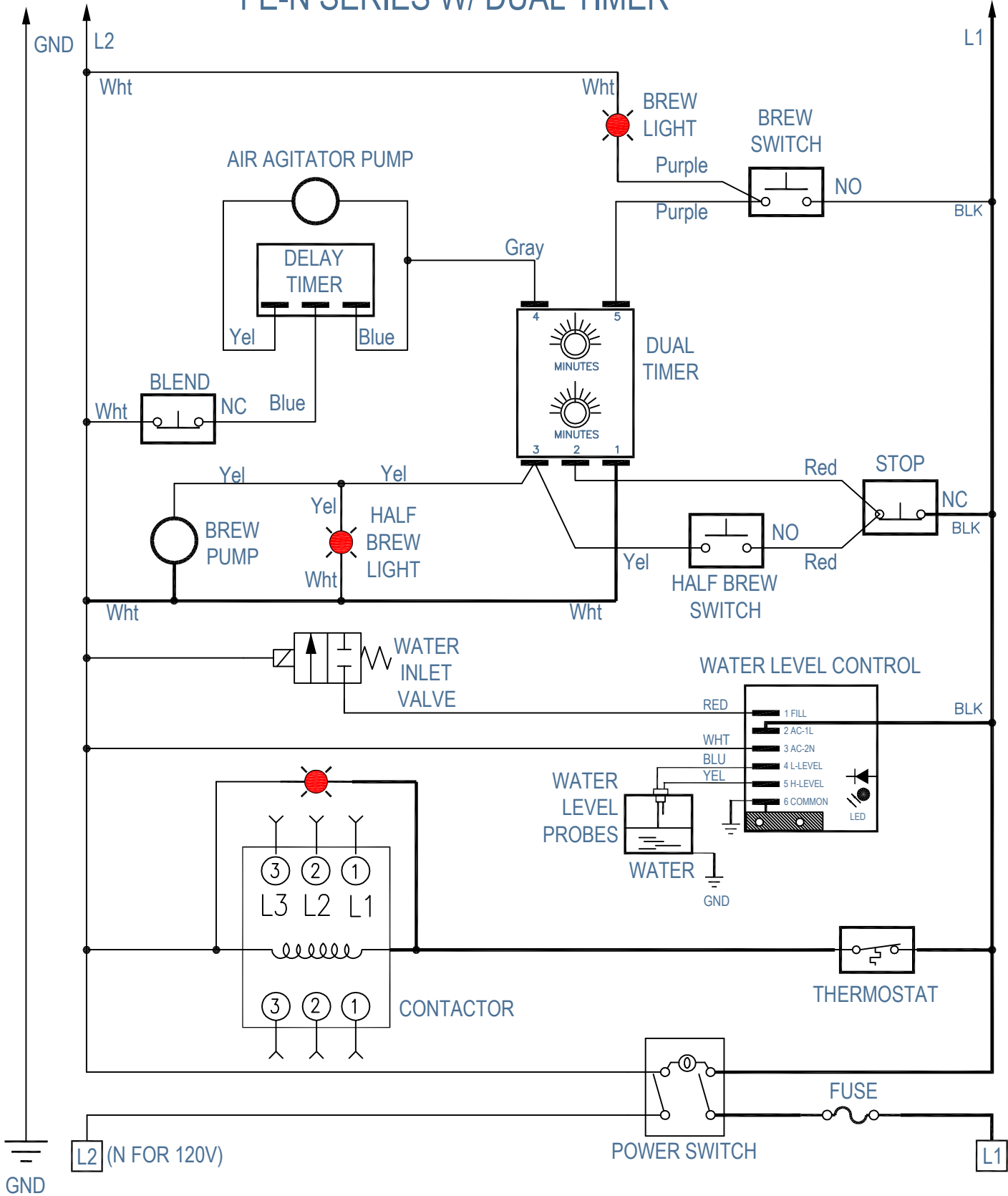

3 GALLON - SINGLES & TWINS

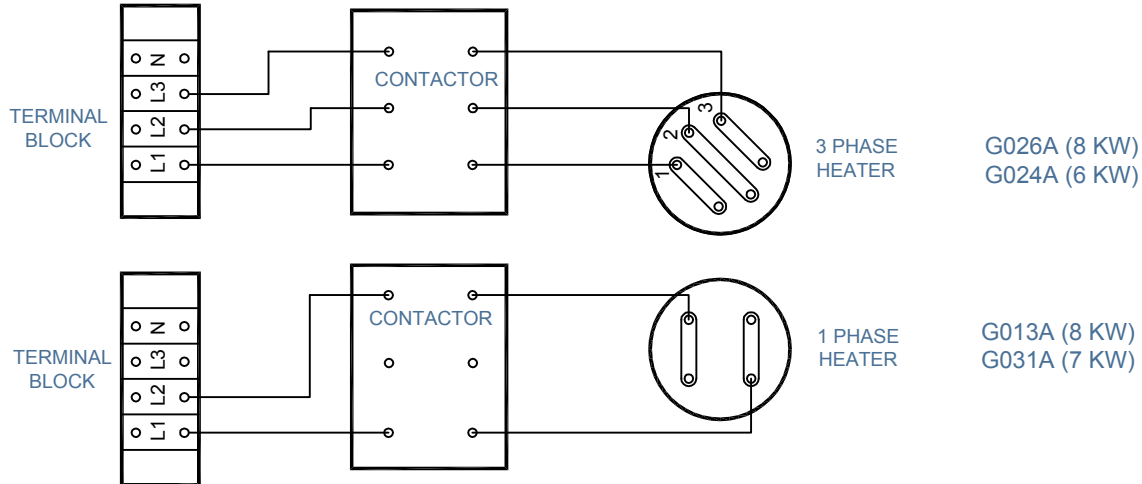

6 GALLON TWINS

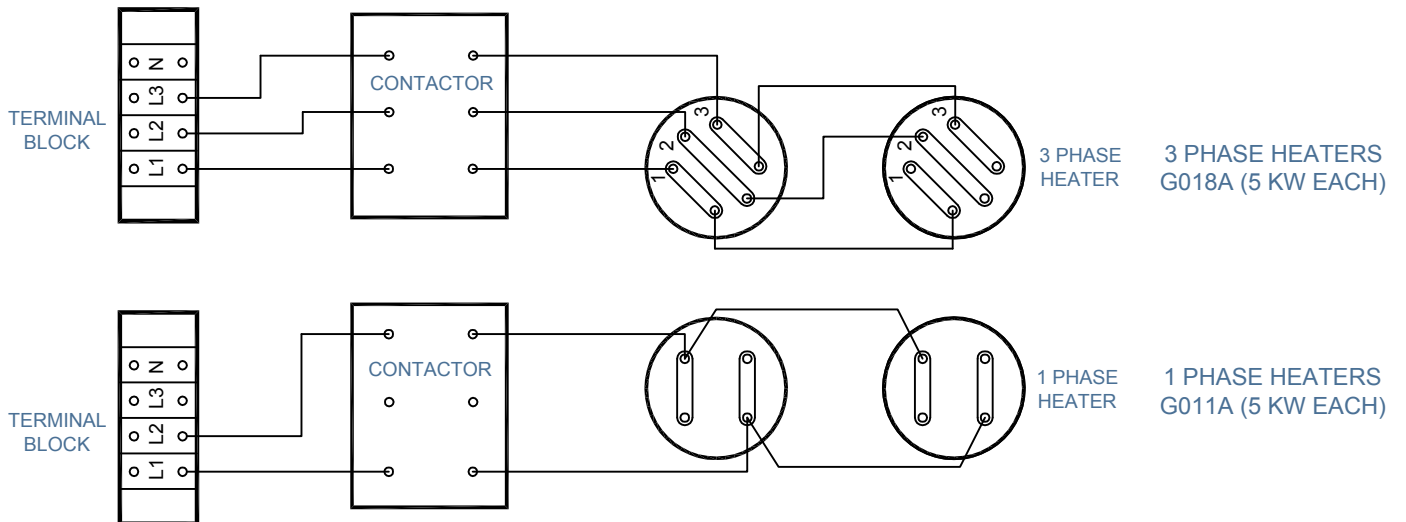

9 GALLON TWINS

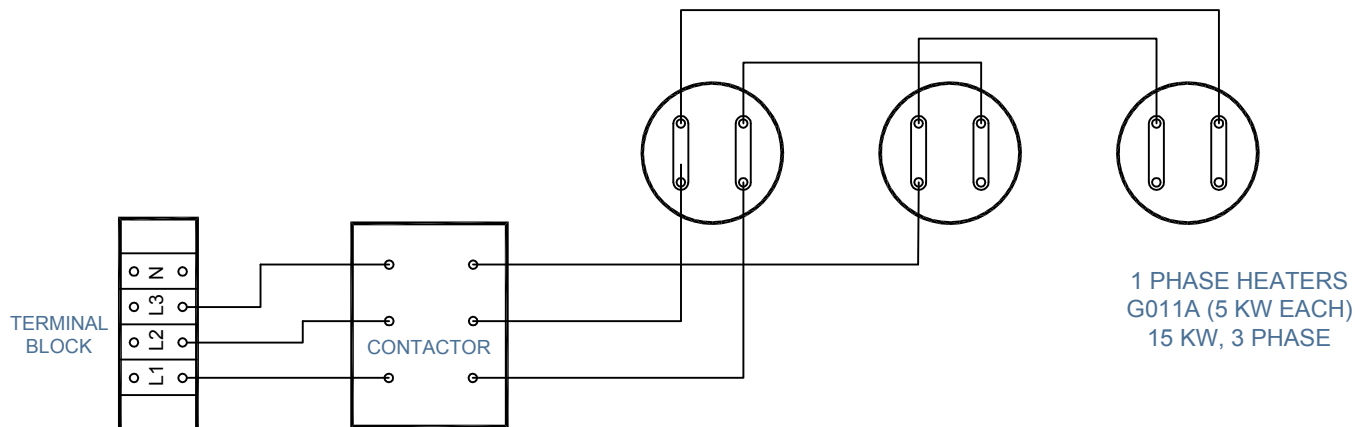

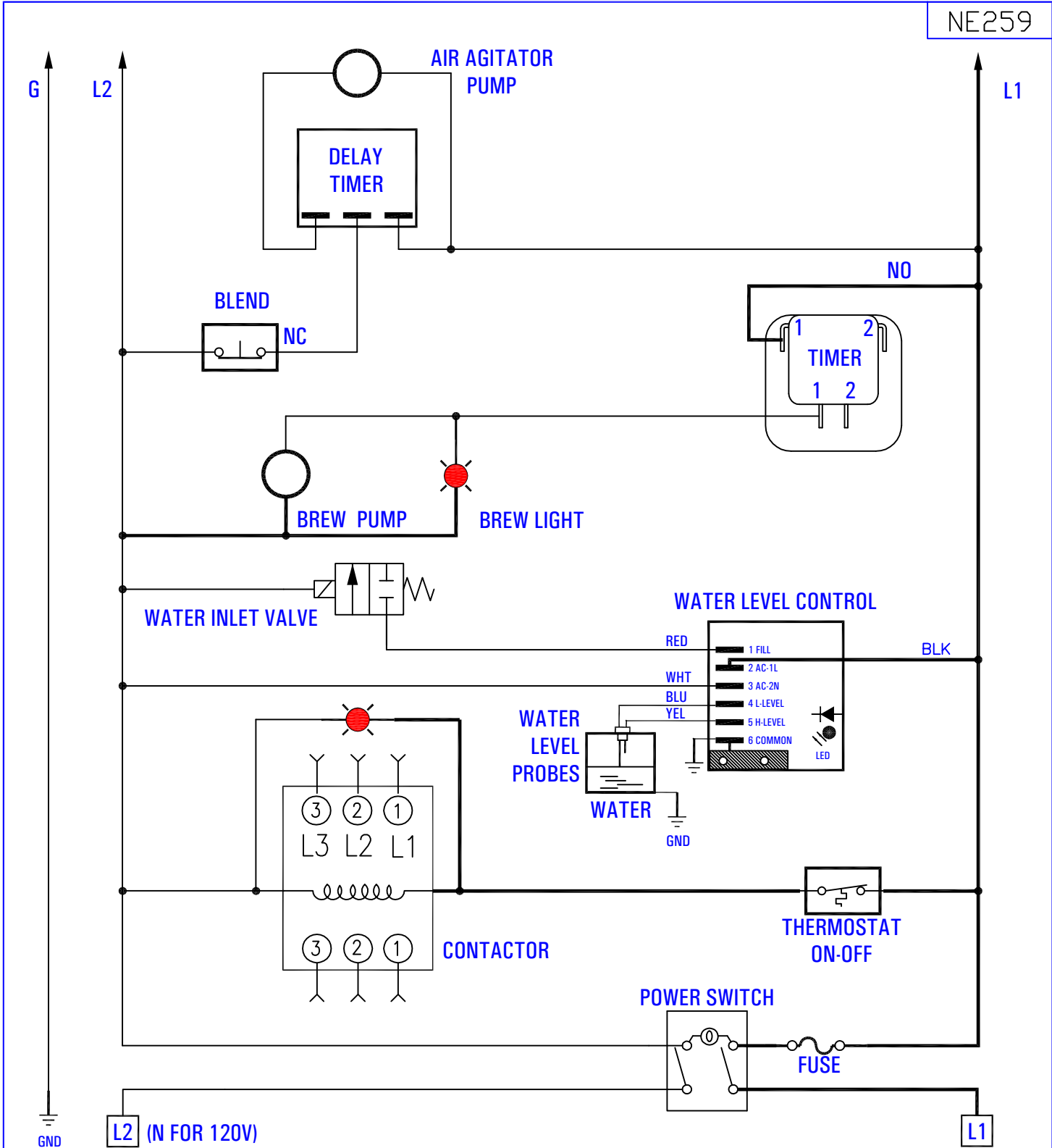

CL-N & CH-N SERIES URNS

REV	BY	DATE	DESCRIPTION	APP'D BY	DATE	PART NO NE259
				DRAWN BY M.M.	DATE 12/2/2005	SCALE 1 : 1
CECILWARE CORPORATION 43-05 20 AVE. L.I.C. NY 11105						NE259
TITLE: ELECTRICAL DIAGRAM (CL-N & CH-N SERIES URNS)						
						REV.