

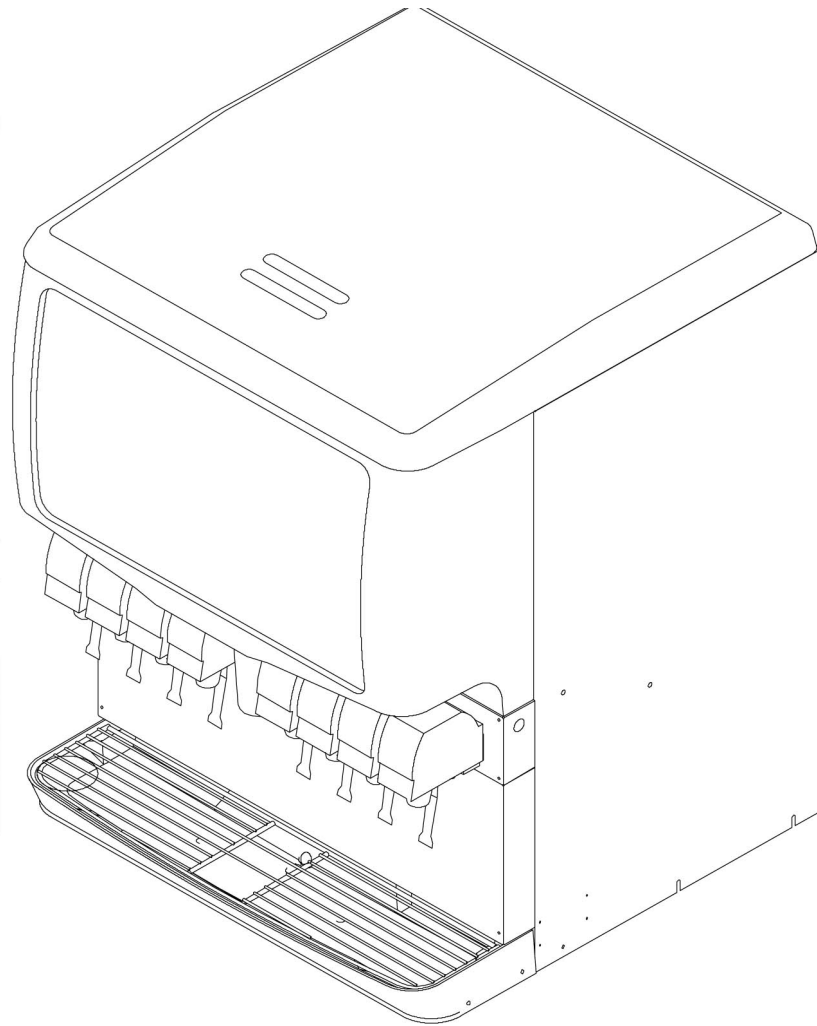

**INSTALLATION MANUAL
ICE/BEVERAGE DISPENSER
MODEL: ENDURO-200/250**



Release Date: March 24, 2004

Publication Number: 92181INS

Revision Date: August 3, 2010

Revision: F

Visit the IMI Cornelius web site at www.cornelius.com for all your Literature needs.

The products, technical information, and instructions contained in this manual are subject to change without notice. These instructions are not intended to cover all details or variations of the equipment, nor to provide for every possible contingency in the installation, operation or maintenance of this equipment. This manual assumes that the person(s) working on the equipment have been trained and are skilled in working with electrical, plumbing, pneumatic, and mechanical equipment. It is assumed that appropriate safety precautions are taken and that all local safety and construction requirements are being met, in addition to the information contained in this manual.

This Product is warranted only as provided in Cornelius' Commercial Warranty applicable to this Product and is subject to all of the restrictions and limitations contained in the Commercial Warranty.

Cornelius will not be responsible for any repair, replacement or other service required by or loss or damage resulting from any of the following occurrences, including but not limited to, (1) other than normal and proper use and normal service conditions with respect to the Product, (2) improper voltage, (3) inadequate wiring, (4) abuse, (5) accident, (6) alteration, (7) misuse, (8) neglect, (9) unauthorized repair or the failure to utilize suitably qualified and trained persons to perform service and/or repair of the Product, (10) improper cleaning, (11) failure to follow installation, operating, cleaning or maintenance instructions, (12) use of "non-authorized" parts (i.e., parts that are not 100% compatible with the Product) which use voids the entire warranty, (13) Product parts in contact with water or the product dispensed which are adversely impacted by changes in liquid scale or chemical composition.

Contact Information:

To inquire about current revisions of this and other documentation or for assistance with any Cornelius product contact:

www.cornelius.com

800-238-3600

Trademarks and Copyrights:

This document contains proprietary information and it may not be reproduced in any way without permission from Cornelius.

Printed in U.S.A.



TABLE OF CONTENTS

Safety Instructions	1
Read and Follow ALL Safety Instructions	1
Safety Overview	1
Recognition	1
Different Types of Alerts	1
Safety Tips	1
Qualified Service Personnel	1
Safety Precautions	2
Shipping And Storage	2
CO2 (Carbon Dioxide) Warning	2
Mounting in or on a Counter	2
description	3
Specifications	3
installation instructions	4
ADJUST WATER -TO-SYRUP RATIO	5
Gate Restrictor Plate	5
Adjustment	6
troubleshooting	16

SAFETY INSTRUCTIONS

READ AND FOLLOW ALL SAFETY INSTRUCTIONS

Safety Overview

- Read and follow **ALL SAFETY INSTRUCTIONS** in this manual and any warning/caution labels on the unit (decals, labels or laminated cards).
- Read and understand **ALL** applicable OSHA (Occupational Safety and Health Administration) safety regulations before operating this unit.

Recognition

<i>Recognize Safety Alerts</i>

<i>This is the safety alert symbol. When you see it in this manual or on the unit, be alert to the potential of personal injury or damage to the unit.</i>

DIFFERENT TYPES OF ALERTS

DANGER:

Indicates an immediate hazardous situation which if not avoided **WILL** result in serious injury, death or equipment damage.

WARNING:

Indicates a potentially hazardous situation which, if not avoided, **COULD** result in serious injury, death, or equipment damage.

CAUTION:

Indicates a potentially hazardous situation which, if not avoided, **MAY** result in minor or moderate injury or equipment damage.

SAFETY TIPS

- Carefully read and follow all safety messages in this manual and safety signs on the unit.
- Keep safety signs in good condition and replace missing or damaged items.
- Learn how to operate the unit and how to use the controls properly.
- **Do not** let anyone operate the unit without proper training. This appliance is **not** intended for use by very young children or infirm persons without supervision. Young children should be supervised to ensure that they do not play with the appliance.
- Keep your unit in proper working condition and do not allow unauthorized modifications to the unit.

QUALIFIED SERVICE PERSONNEL

WARNING:

Only trained and certified electrical, plumbing and refrigeration technicians should service this unit. **ALL WIRING AND PLUMBING MUST CONFORM TO NATIONAL AND LOCAL CODES. FAILURE TO COMPLY COULD RESULT IN SERIOUS INJURY, DEATH OR EQUIPMENT DAMAGE.**

SAFETY PRECAUTIONS

This unit has been specifically designed to provide protection against personal injury. To ensure continued protection observe the following:

WARNING:

Disconnect power to the unit before servicing following all lock out/tag out procedures established by the user. Verify all of the power is off to the unit before any work is performed.

Failure to disconnect the power could result in serious injury, death or equipment damage.

CAUTION:

Always be sure to keep area around the unit clean and free of clutter. Failure to keep this area clean may result in injury or equipment damage.

SHIPPING AND STORAGE

CAUTION:

Before shipping, storing, or relocating the unit, the unit must be sanitized and all sanitizing solution must be drained from the system. A freezing ambient environment will cause residual sanitizing solution or water remaining inside the unit to freeze resulting in damage to internal components.

CO₂ (CARBON DIOXIDE) WARNING

DANGER:

CO₂ displaces oxygen. Strict attention **MUST** be observed in the prevention of CO₂ gas leaks in the entire CO₂ and soft drink system. If a CO₂ gas leak is suspected, particularly in a small area, **IMMEDIATELY** ventilate the contaminated area before attempting to repair the leak. Personnel exposed to high concentrations of CO₂ gas experience tremors which are followed rapidly by loss of consciousness and **DEATH**.

MOUNTING IN OR ON A COUNTER

WARNING:

When installing the unit in or on a counter top, the counter must be able to support a weight in excess of 580 lbs. to insure adequate support for the unit. **FAILURE TO COMPLY COULD RESULT IN SERIOUS INJURY, DEATH OR EQUIPMENT DAMAGE.**

NOTE: Many units incorporate the use of additional equipment such as icemakers. When any addition equipment is used you must check with the equipment manufacturer to determine the additional weight the counter will need to support to ensure a safe installation.

DESCRIPTION

The "ENDURO" series of ice dispensers solves your ice and beverage service needs in a sanitary, space saving, economical way. Designed to be manually filled with ice from any remote ice making source, these dispensers will dispense cubes (up to 1-1/4 in. in size), cubelets, and hard-chipped or cracked ice; and in addition, several flavors of post-mix beverages. The "BC" units include beverage faucets and a cold plate and are designed to be supplied direct from syrup tanks and a carbonator, with no additional cooling required.

SPECIFICATIONS

Model	ED200 (Ice Only)	ED250 (Ice Only)
	B (Beverage Faucets)	B (Beverage Faucets)
	C (Cold Plate)	C (Cold Plate)
	Z (No drip tray)	Z (No drip tray)
	N (No Lid)	N (No Lid)
	F (Flavor)	F (Flavor)
Ice storage	200 pounds	250 pounds
Maximum No. of Beverage Faucets Available	10	10
Cold Plate (Built-In)	Yes, On BC Model Only	Yes, On BC Model Only
Electrical	120/1/60, 3.5 Amps 220--240/1/50--60, 2.0 Amps	120/1/60, 3.5 Amps 220--240/1/50--60, 2.0 Amps
Dimensions	30 in. Wide X 30-11/16 in. Deep X 35-5/8 in. High	30 in. Wide X 30-11/16 in. Deep X 39-5/8 in. High
Z Models	30 in. Wide X 23-1/16 in. Deep X 35-5/8 in. High	30 in. Wide X 23-1/16 in. Deep X 39-5/8 in. High

INSTALLATION INSTRUCTIONS

1. Locate the dispenser indoors on a level counter top.

A. LEG OPTION

NOTE: Before installing legs, the plastic plugs must be removed.

Unpack the four (4) legs and install them into the threaded holes provided in the bottom of the unit. The installer must provide flexibility in the product and utility supply lines to permit shifting the position of the dispenser sufficiently to clean the area beneath it. Rotate the line support bracket, located under base, to the down position and route all the lines above the bracket.

B. COUNTER MOUNTING

The ice dispenser must be sealed to the counter. The MOUNTING TEMPLATE (see Figure 3) indicates where openings can be cut in the counter. Locate the desired position for the dispenser, then mark the outline dimensions on the counter using the MOUNTING TEMPLATE. Cut openings in the counter. Rotate the line support bracket, located under base, to the up position and route all the lines below the bracket.

Apply a continuous bead of National Sanitation Foundation (NSF) listed silastic sealant (Dow 732 or equal) approximately 1/4" inside of the unit outline dimensions and around all openings. Then, position the unit on the counter within the outline dimensions. All excess sealant must be wiped away immediately.

2. The beverage tubes, drain tube and power cord are routed through the large opening in the bottom of the unit. See the MOUNTING TEMPLATE (see Figure 3), for locating the required clearance hole in the counter

for these utility lines.

3. DRIP TRAY DRAIN ASSEMBLY (see Figure 4). Route the drain tube to an open drain with the end of the tube above the "flood" level of the drain. Use the tubing, fittings, clamps, and insulation provided with the Dispenser to assemble the drain. The completed drain line *must* pitch continuously downward and contain no "traps" or improper drainage will result.

NOTE: This equipment must be installed with adequate backflow protection to comply with federal, state, and local codes.

4. Connect the beverage system product tubes as indicated in the applicable Flow Diagram. This work should be done by a qualified Service Person. Any non-carbonated water tubing must be connected to the outlet of the check valve.

NOTE: See applicable Flow Diagram (see Figure 5, 6, 7, or 8) or decal on lower front panel of the unit for the location of syrup and water connections.

NOTE: Water pipe connections and fixtures directly connected to a potable water supply shall be sized, installed and maintained according to Federal, State and Local Laws.

5. Clean the hopper interior (see Owner's Manual P/N 92108 for cleaning instructions).



WARNING:

This unit must be grounded to avoid possible fatal electrical shock or serious injury to the operator. The unit power cord is equipped with a three prong plug. If a Three-hole (grounded) outlet is not available, use an approved method to ground the unit. Failure to comply could result in serious injury, death or damage to the equipment.

6. Connect the power cord to a 120 volt, 60 cycle, 3-wire grounded receptacle. For 220-240 volt units, a 3-wire power cord is provided. An adapter plug for the particular country must be provided by the equipment Installer.
7. Maximum and minimum ambient temperature rating for correct operation is 40° to 105°F.
8. The dispenser is not designed for a wash down environment and must not be placed in an area where a water jet could be used.
9. The unit has to be placed in a horizontal position.
10. If the supply cord is damaged, it must be replaced by the manufacturer, it's service agent or similarly qualified person in order to avoid a hazard.

ADJUST WATER -TO-SYRUP RATIO

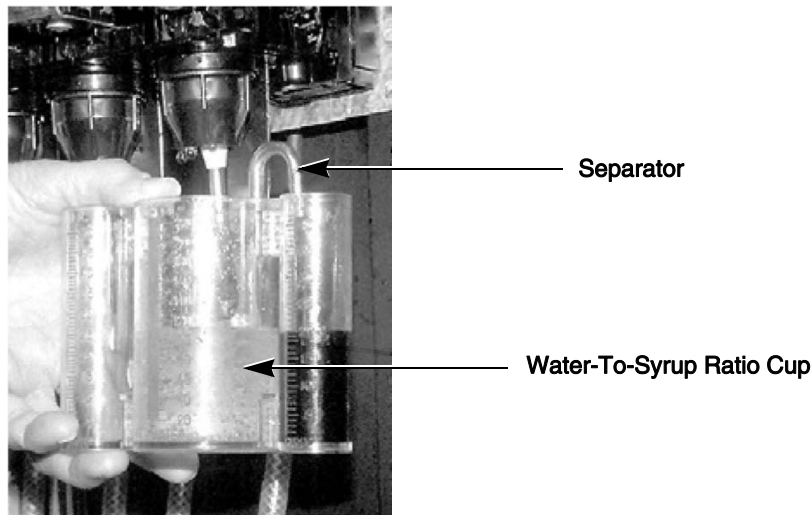

Figure 1. Ratio Cup

1. Remove valve cover and install syrup separator over the diffuser and through the nozzle.
2. Hold cup under valve and dispenser beverage for a specific time (i.e. 2 seconds)
NOTE: Water and syrup must be cold before checking ratios.
3. Adjust carbonated water flow to the desired rate (such as 90 to 100 ml (3 to 3.75 oz.) per second). Turn the flow adjuster 1/4 of a turn at a time and recheck the flow. To increase reading turn clockwise.
4. Set a syrup flow adjuster to get the desired ratio.
5. Test the valve and adjust until a consistent ratio is delivered three consecutive times.
6. Repeat procedure for other valves.

GATE RESTRICTOR PLATE

CAUTION:

Disconnect power to dispenser before installing, removing or adjusting restrictor. See Safety Section of this manual.

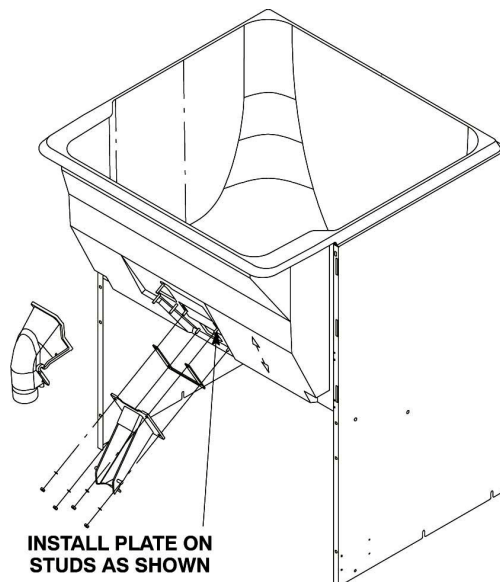
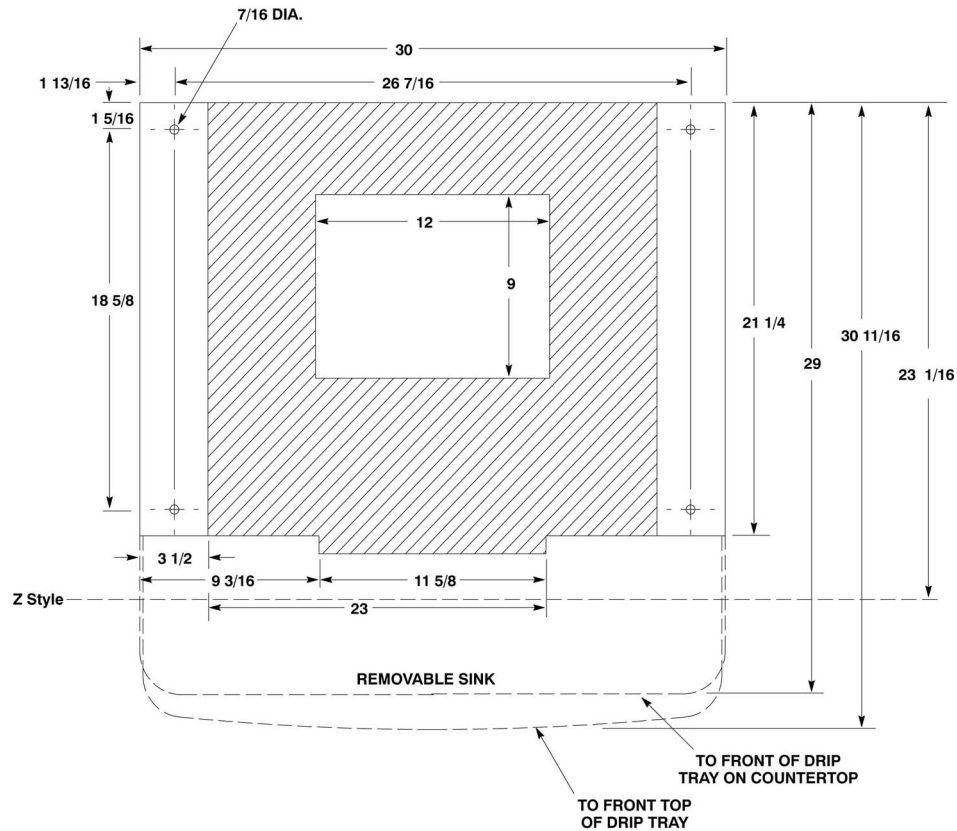

Figure 2. Gate Restrictor Plate

ADJUSTMENT

This plate may be adjusted as shown to reduce or increase the dispensing rate of ice, especially desirable when using glasses or other containers with small openings. Adjustment can be made by sliding up or down with nuts loosened, to obtain the desired amount of restriction.



NOTE: Recommended counter opening size 9" X 12" for utilities and beverage tubing. Opening can be located anywhere within the shaded area.

Figure 3. Mounting Template

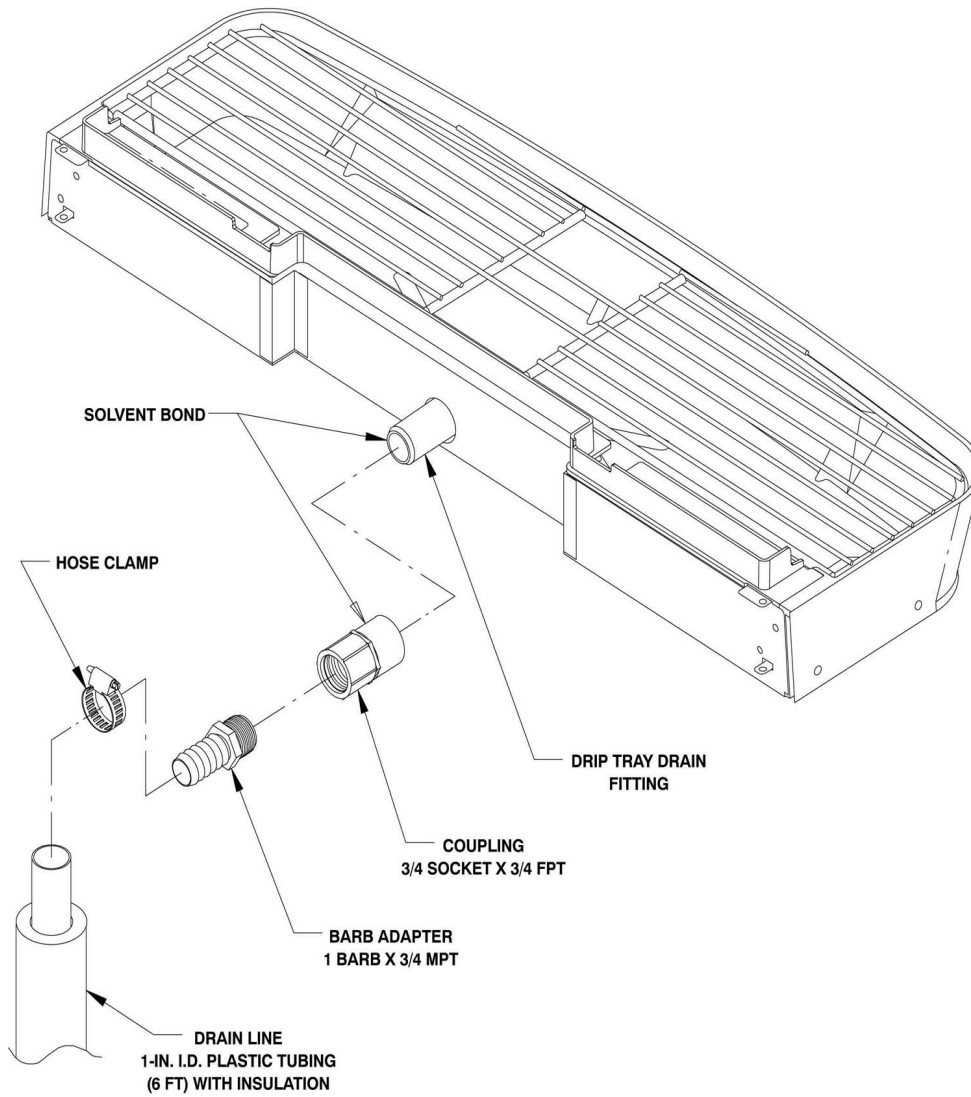

Figure 4. Drip Tray Drain Assembly

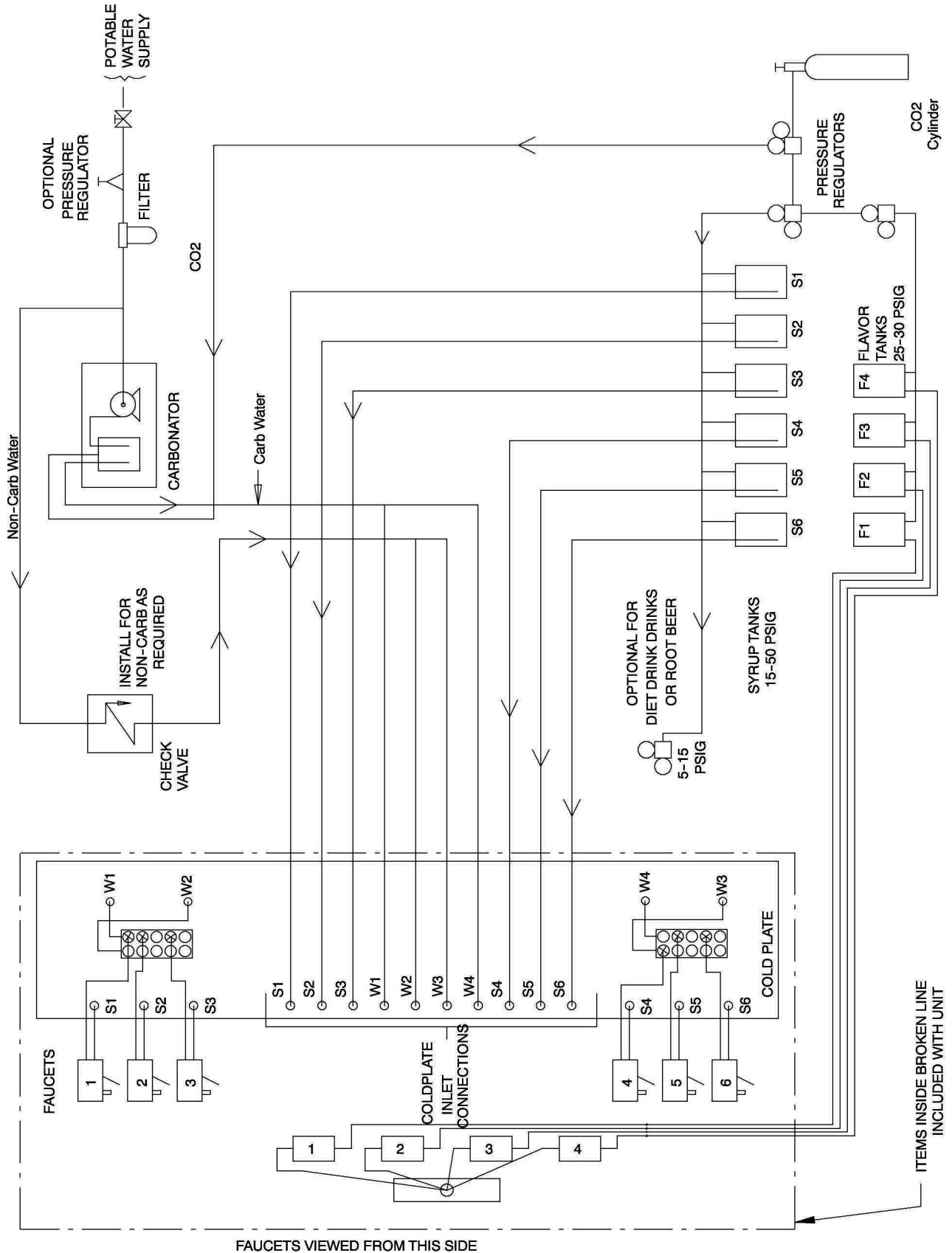

Figure 5. Flow Diagram (Unit with Six Faucets)

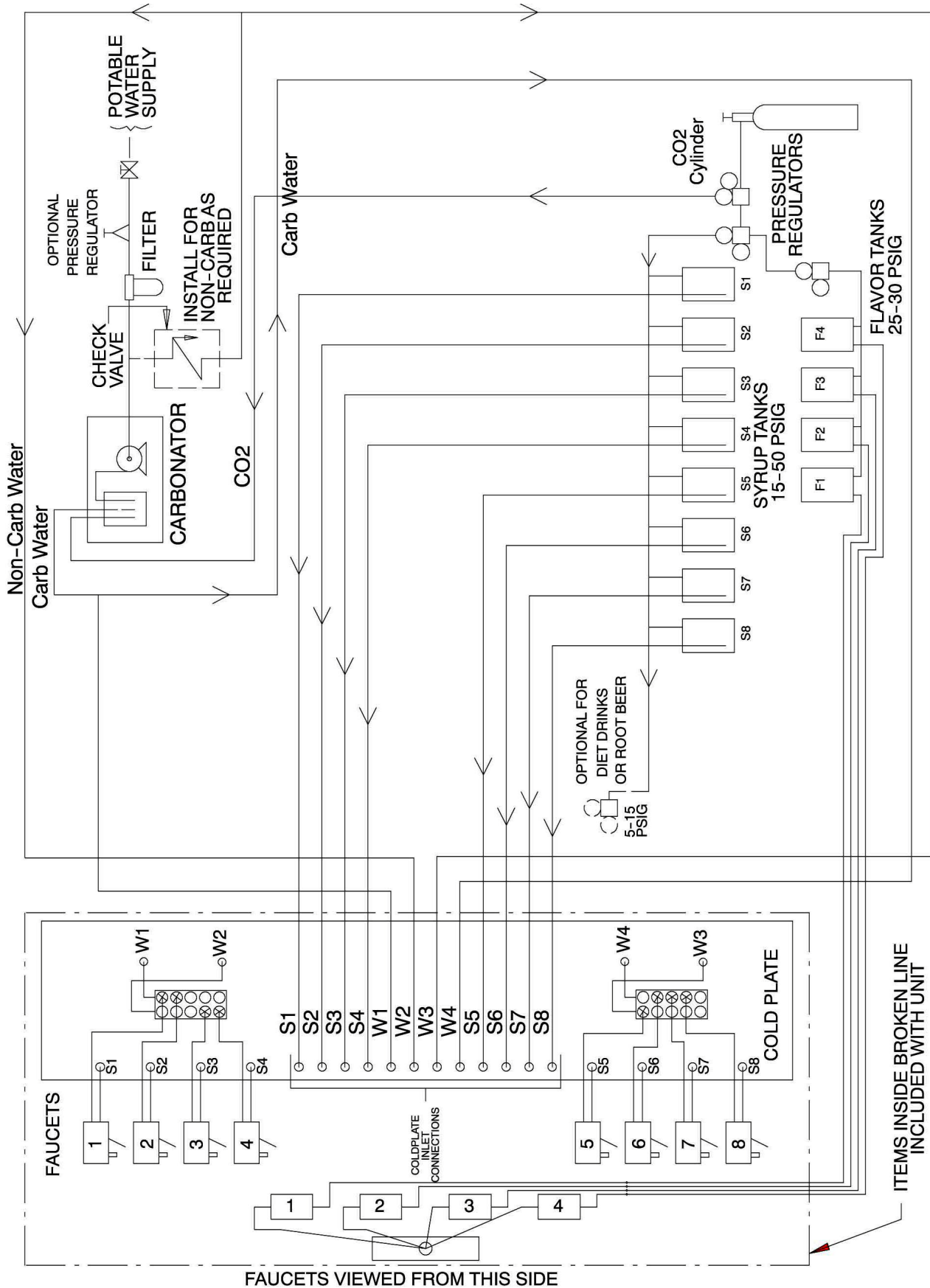

Figure 6. Flow Diagram (Unit with Eight Faucets)

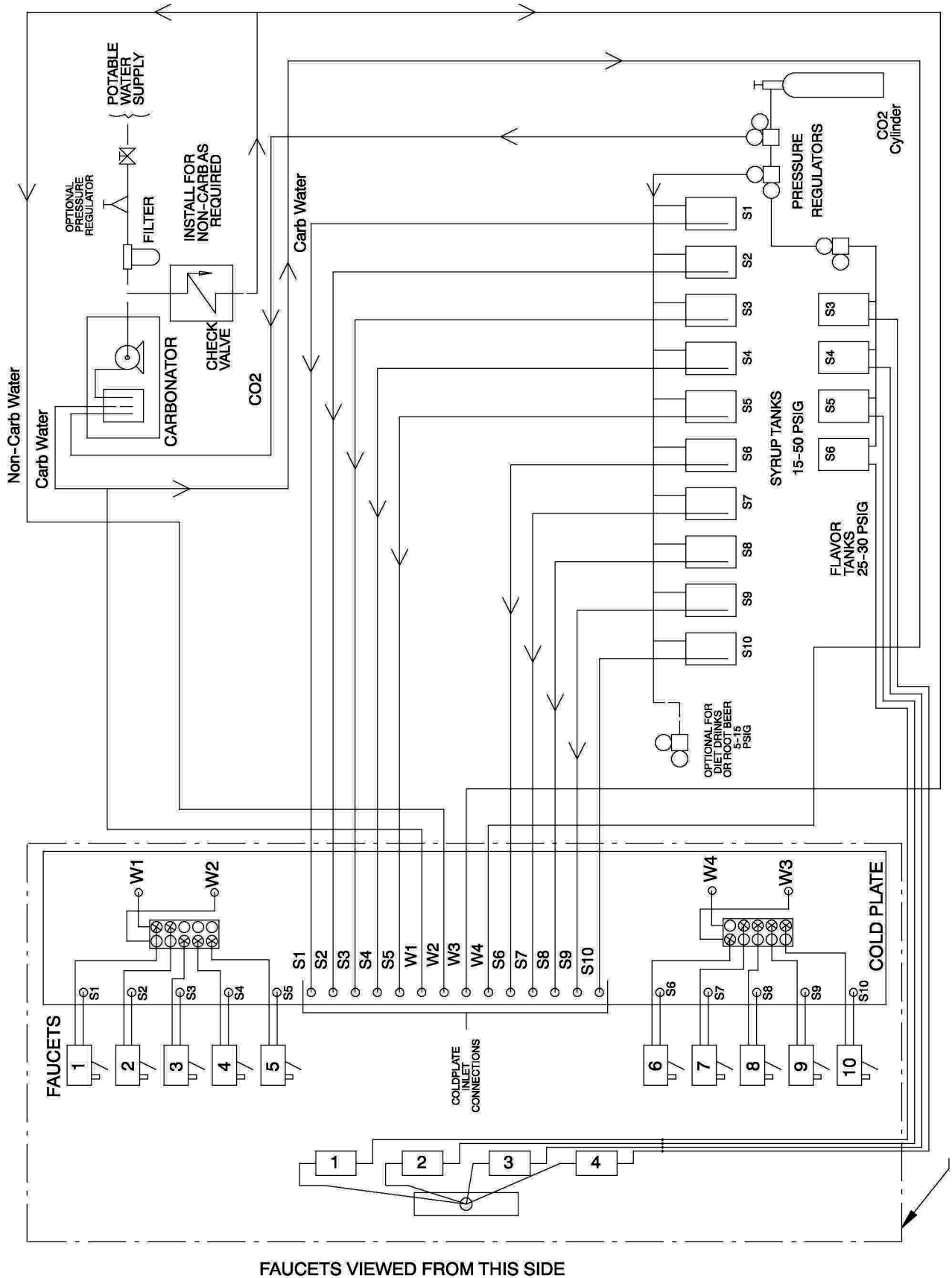

Figure 7. Flow Diagram (Unit with Ten Faucets)

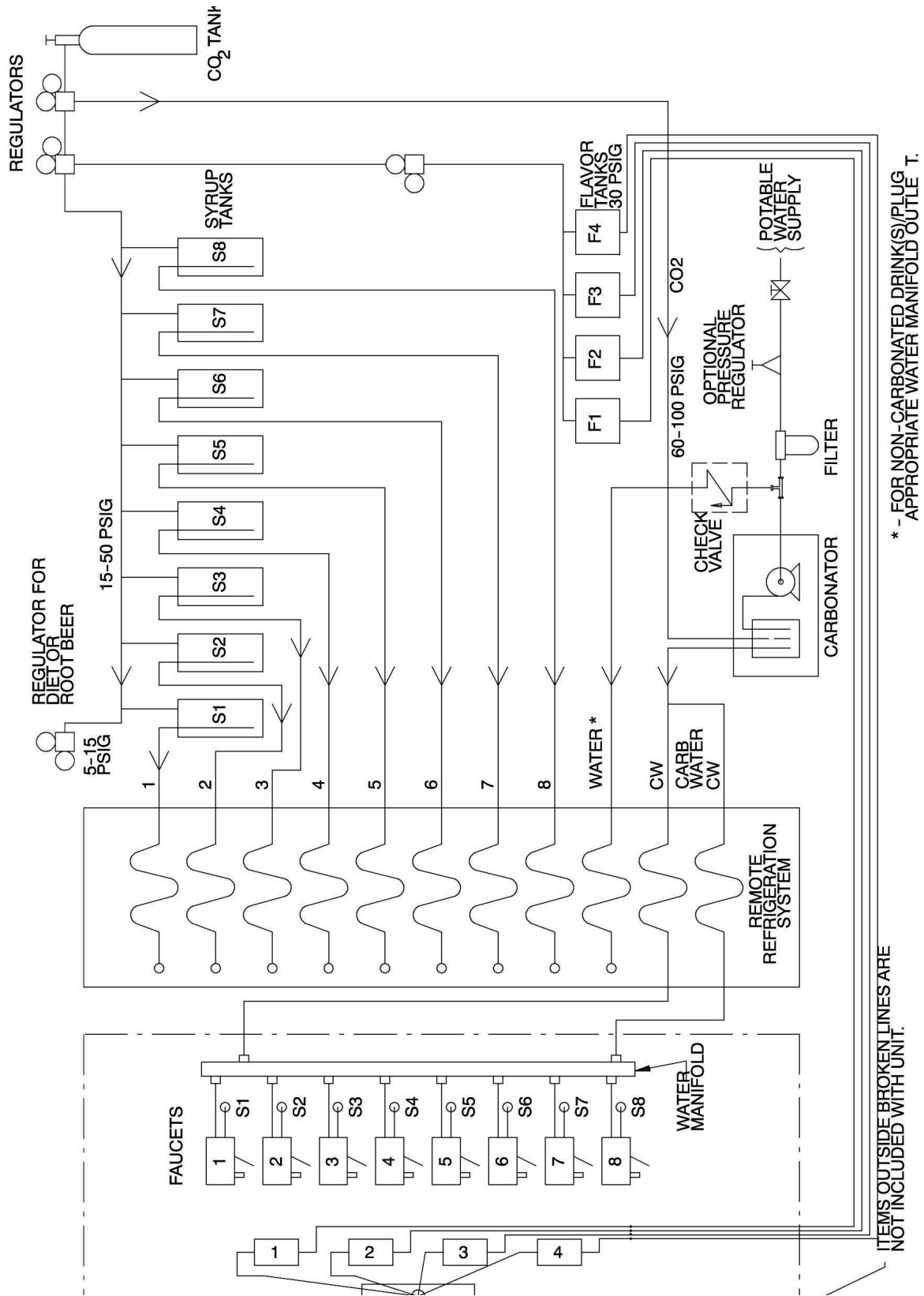

Figure 8. Flow Diagram ("B" Unit with Eight Beverage Faucets)

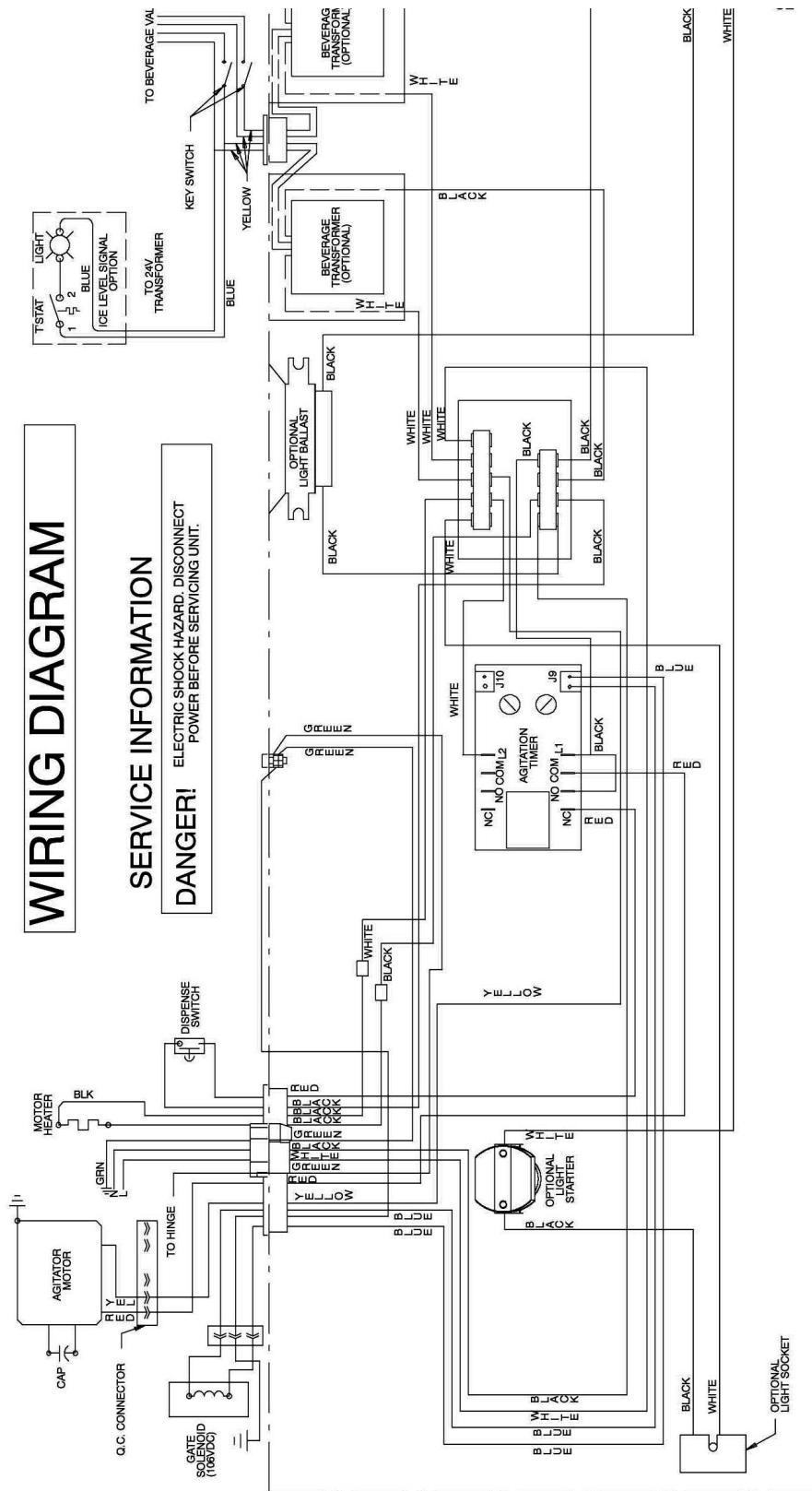

Figure 9. Wiring Diagram (115 Volts Unit)

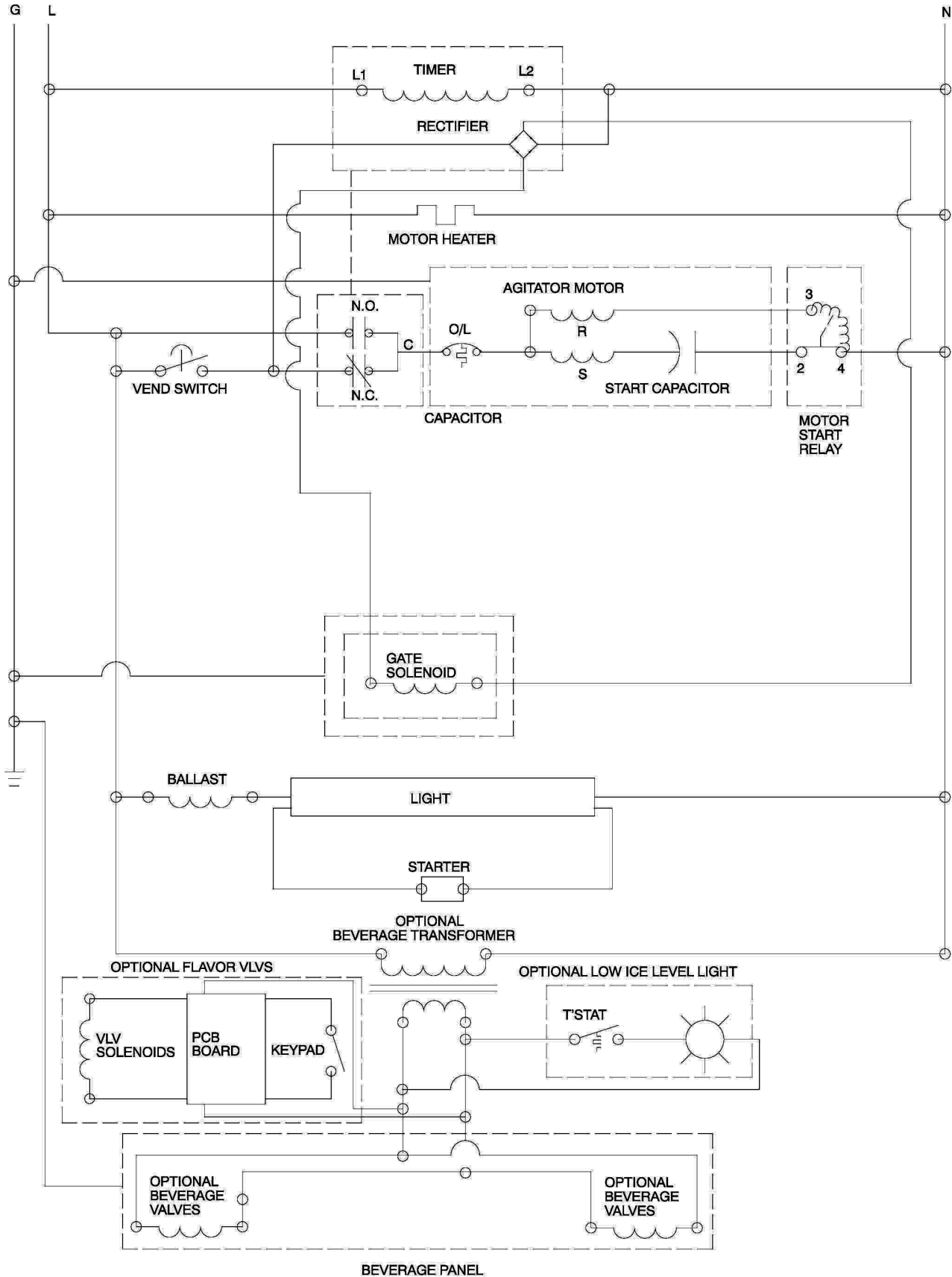

Figure 10. Schematic (115 Volt Unit)

WIRING DIAGRAM SERVICE INFORMATION

(220-240 VAC)

DANGER! ELECTRIC SHOCK HAZARD. DISCONNECT POWER BEFORE SERVICING UNIT.

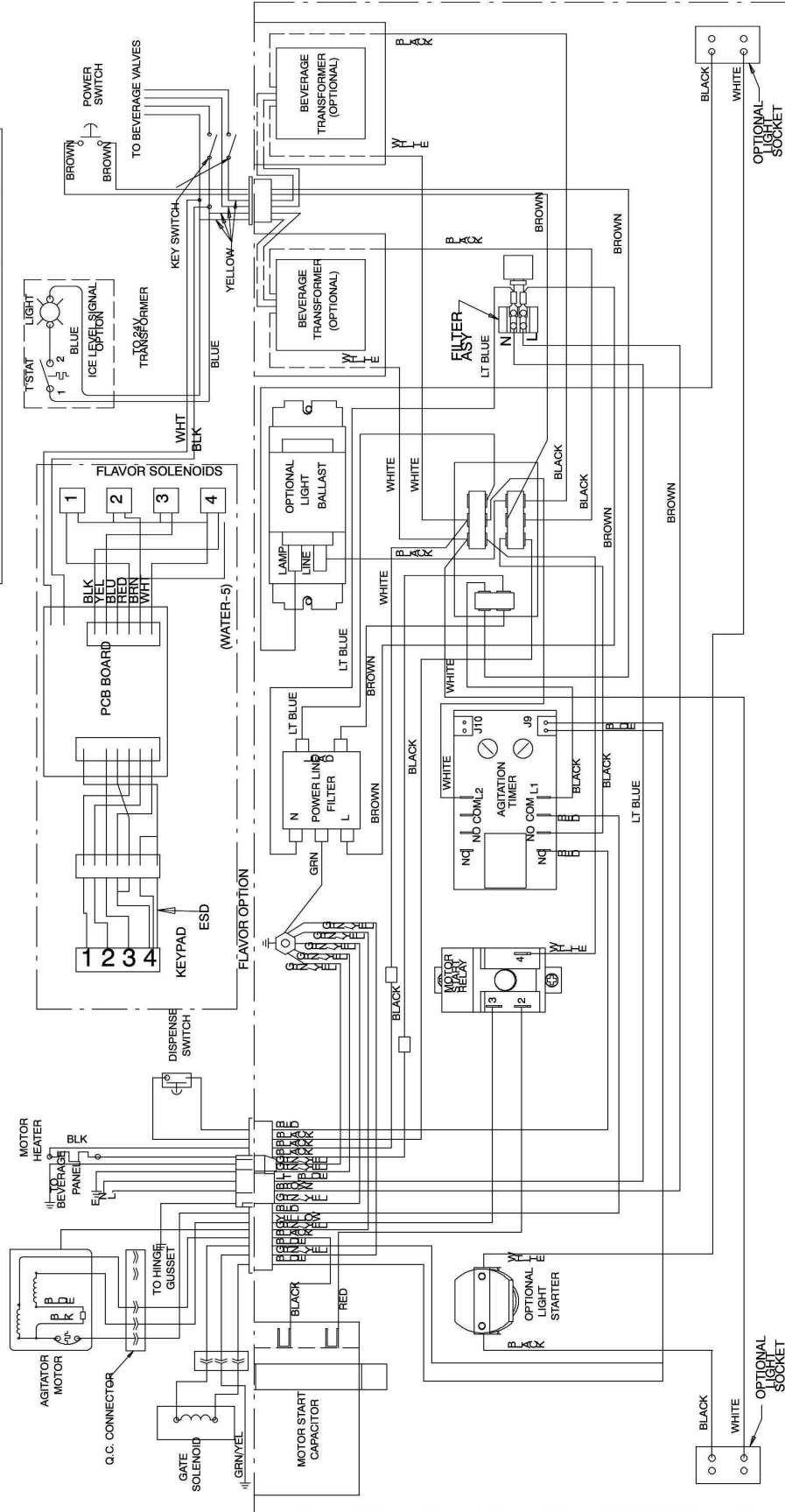

Figure 11. Wiring Diagram (220-240 Volt Unit)

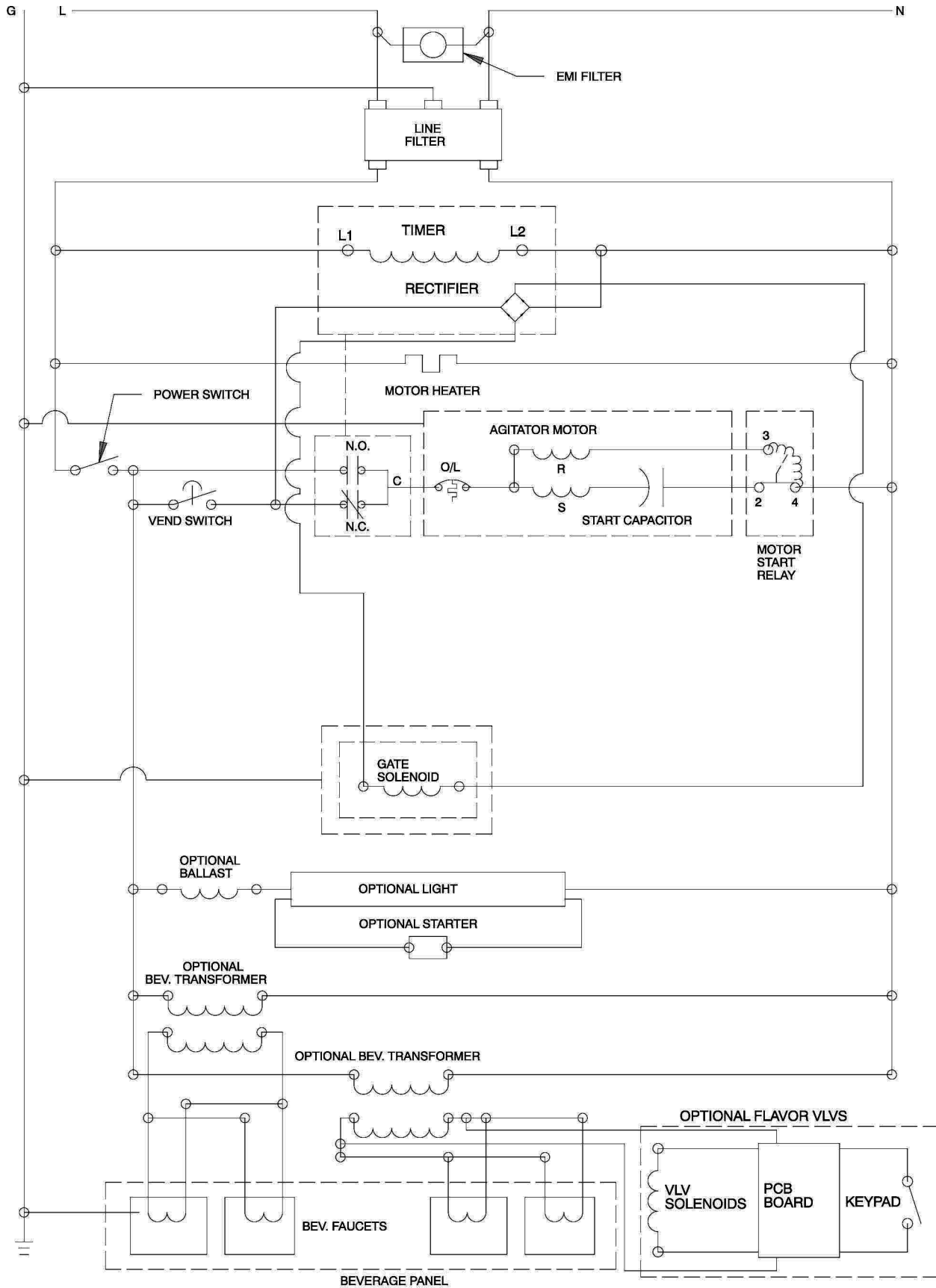

Figure 12. Schematic (220-240 Volt Unit)

TROUBLESHOOTING

IMPORTANT: Only qualified personnel should service internal components or electrical wiring.



WARNING:

If repairs are to be made to a product system, remove quick disconnects from the applicable product tank, then relieve the system pressure before proceeding. If repairs are to be made to the CO₂ system, stop dispensing, shut off the CO₂ supply, then relieve the system pressure before proceeding. If repairs are to be made to the refrigeration system, make sure electrical power is disconnected from the unit.

Should your unit fail to operate properly, check that there is power to the unit and that the hopper contains ice. If the unit does not dispense, check the following chart under the appropriate symptoms to aid in locating the defect.

Trouble	Probable Cause
BLOWN FUSE OR CIRCUIT BREAKER.	A. Short circuit in wiring. B. Defective gate solenoid. C. Defective agitator motor.
GATE DOES NOT OPEN. AGITATOR DOES NOT TURN.	A. No power. B. Bent depressor plate (does not actuate switch). C. Defective dispensing switch.
GATE DOES NOT OPEN OR IS SLUGGISH. AGITATOR TURNS	A. Defective gate solenoid. B. Excessive pressure against gate slide. C. Defective Rectifier.
ICE DISPENSES CONTINUOUSLY.	A. Stuck or bent depressor plate (does not release switch). B. Defective dispensing switch. C. Improper switch installation.
SLUSHY ICE. WATER IN HOPPER.	A. Blocked Drain. B. Unit not level. C. Poor ice quality due to water quality or icemaker problems. D. Improper use of flaked ice.
BEVERAGES DO NOT DISPENSE.	A. No 24 volt power to faucets. B. No CO ₂ pressure.
BEVERAGES TOO SWEET.	A. Carbonator not working. B. No CO ₂ pressure in carbonator. C. Faucet brix requires adjusting.
BEVERAGE NOT SWEET ENOUGH.	A. Empty syrup tank. B. Faucet brix requires adjusting.
BEVERAGES NOT COLD (UNITS WITH BUILT-IN COLD PLATE).	A. Unit standing with no ice in hopper or no ice in cold plate cabinet.
FLAVOR SYRUPS DO NOT DISPENSE.	A. No 24 volt power to PC board. B. No CO ₂ pressure. C. Empty syrup tank. D. Kinked tubing. E. Clogged inner nozzle. F. Defective PC board. G. Defective harness from keypad. H. Defective Flow control. I. Defective solenoid harness. J. Defective keypad



FLAVOR DISPENSES FOR MORE THAN 1 SEC.	A. Dip switch settings on control board incorrect. B. PC board defective. C. Defective flow control.
FLAVOR DISPENSES MORE THAN .5 OZ.	A. Dip switch settings on control board incorrect. B. Flow control incorrectly set. C. PC board defective. D. Defective flow control.

Contact your local syrup or beverage equipment distributor for additional information and troubleshooting of beverage system.



IMI Cornelius Inc.
www.cornelius.com