

# **BUNN**®

*CDBC-DV, CDBCF-DV*  
*CDBC-DV, CDBCF APS-DV*  
*CDBCF LPTC-DV*  
*CDBC-MV, CDBCF-MV*  
*CDBC-MV, CDBCF APS-MV*

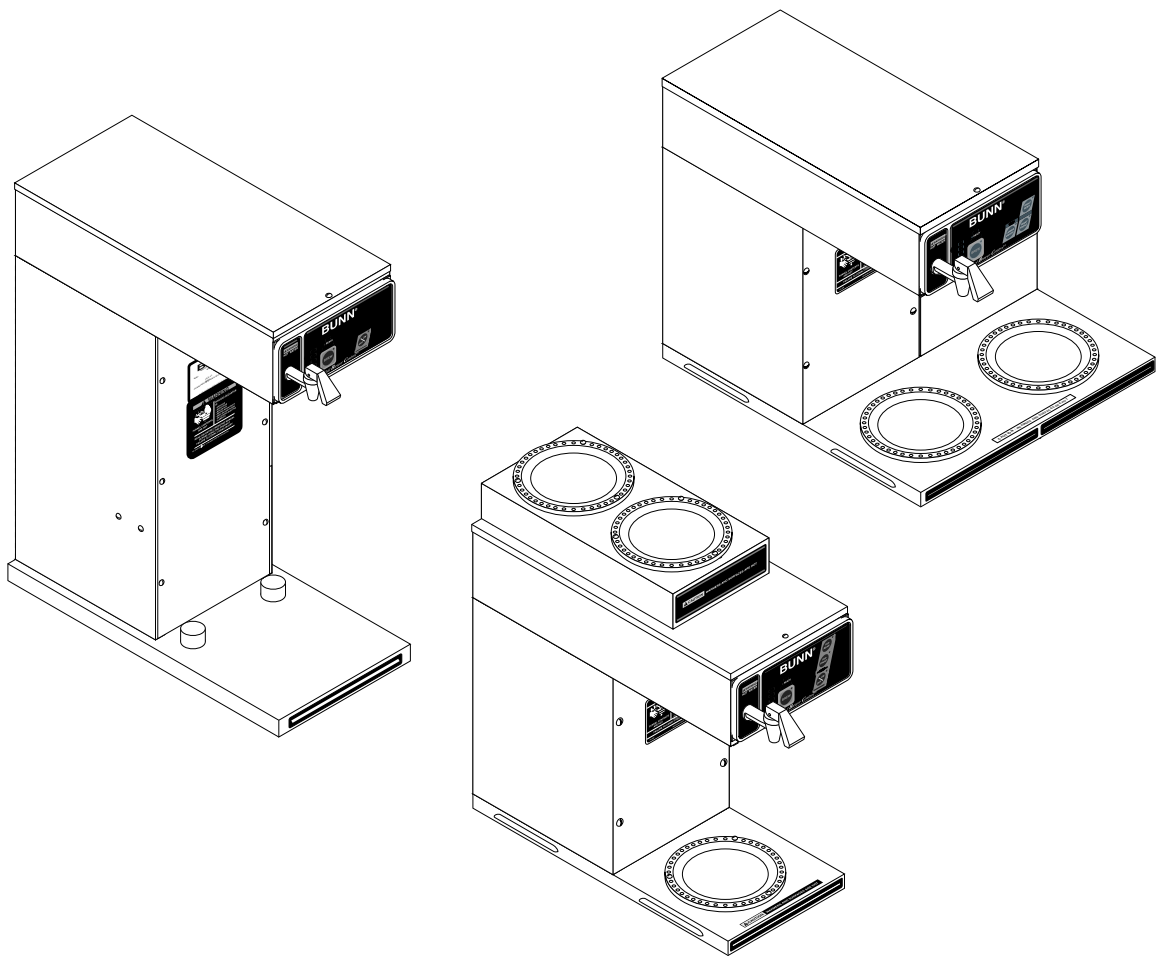

## **OPERATING & SERVICE MANUAL**

**BUNN-O-MATIC CORPORATION**

POST OFFICE BOX 3227

SPRINGFIELD, ILLINOIS 62708-3227

PHONE: (217) 529-6601 FAX: (217) 529-6644

## INTRODUCTION

This equipment will brew a half-gallon batch of coffee into an awaiting dispenser. It can be easily configured for 120V 15 amp, 120V 20 amp (MV models only), 120/208V 20 amp or 120/240V 20 amp. The brewer may have a hot water faucet for allied beverage use. It is only for indoor use on a sturdy counter or shelf.

### BUNN-O-MATIC COMMERCIAL PRODUCT WARRANTY

Bunn-O-Matic Corp. ("BUNN") warrants equipment manufactured by it as follows:

- 1) All equipment other than as specified below: 2 years parts and 1 year labor.
- 2) Electronic circuit and/or control boards: parts and labor for 3 years.
- 3) Compressors on refrigeration equipment: 5 years parts and 1 year labor.
- 4) Grinding burrs on coffee grinding equipment to grind coffee to meet original factory screen sieve analysis: parts and labor for 3 years or 30,000 pounds of coffee, whichever comes first.

These warranty periods run from the date of installation BUNN warrants that the equipment manufactured by it will be commercially free of defects in material and workmanship existing at the time of manufacture and appearing within the applicable warranty period. This warranty does not apply to any equipment, component or part that was not manufactured by BUNN or that, in BUNN's judgment, has been affected by misuse, neglect, alteration, improper installation or operation, improper maintenance or repair, damage or casualty. This warranty is conditioned on the Buyer 1) giving BUNN prompt notice of any claim to be made under this warranty by telephone at (217) 529-6601 or by writing to Post Office Box 3227, Springfield, Illinois 62708-3227; 2) if requested by BUNN, shipping the defective equipment prepaid to an authorized BUNN service location; and 3) receiving prior authorization from BUNN that the defective equipment is under warranty.

**THE FOREGOING WARRANTY IS EXCLUSIVE AND IS IN LIEU OF ANY OTHER WARRANTY, WRITTEN OR ORAL, EXPRESS OR IMPLIED, INCLUDING, BUT NOT LIMITED TO, ANY IMPLIED WARRANTY OF EITHER MERCHANTABILITY OR FITNESS FOR A PARTICULAR PURPOSE.** The agents, dealers or employees of BUNN are not authorized to make modifications to this warranty or to make additional warranties that are binding on BUNN. Accordingly, statements by such individuals, whether oral or written, do not constitute warranties and should not be relied upon.

If BUNN determines in its sole discretion that the equipment does not conform to the warranty, BUNN, at its exclusive option while the equipment is under warranty, shall either 1) provide at no charge replacement parts and/or labor (during the applicable parts and labor warranty periods specified above) to repair the defective components, provided that this repair is done by a BUNN Authorized Service Representative; or 2) shall replace the equipment or refund the purchase price for the equipment.

**THE BUYER'S REMEDY AGAINST BUNN FOR THE BREACH OF ANY OBLIGATION ARISING OUT OF THE SALE OF THIS EQUIPMENT, WHETHER DERIVED FROM WARRANTY OR OTHERWISE, SHALL BE LIMITED, AT BUNN'S SOLE OPTION AS SPECIFIED HEREIN, TO REPAIR, REPLACEMENT OR REFUND.**

In no event shall BUNN be liable for any other damage or loss, including, but not limited to, lost profits, lost sales, loss of use of equipment, claims of Buyer's customers, cost of capital, cost of down time, cost of substitute equipment, facilities or services, or any other special, incidental or consequential damages.

## USER NOTICES

Carefully read and follow all notices in this manual and on the equipment. All labels on the equipment should be kept in good condition. Replace any unreadable or damaged labels.



#00658.0000

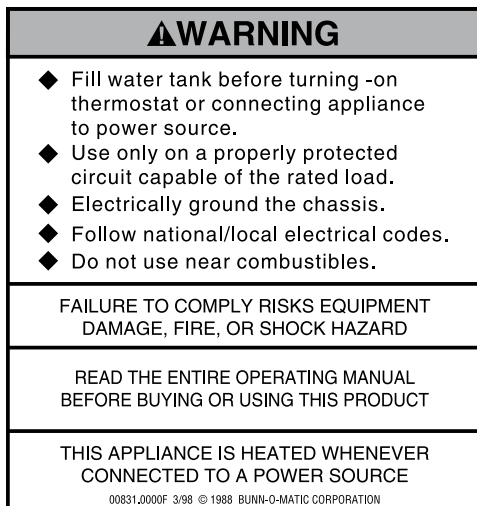

#00831.0000

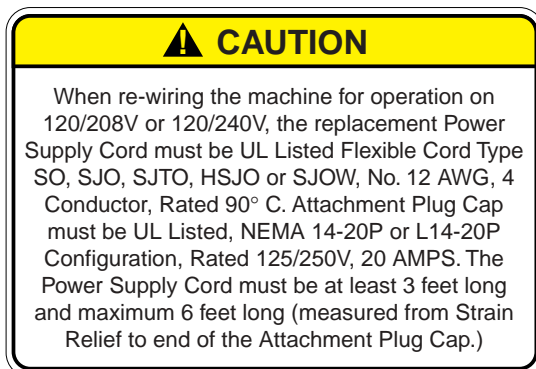

#34072.0000

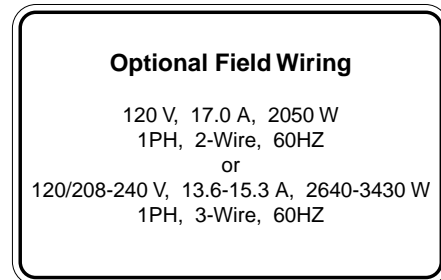

#29710.0002 (MV models only)  
TWO WARMER BREWERS

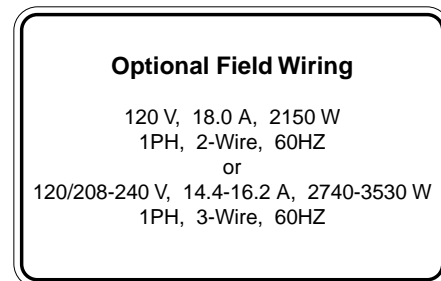

#29710.0000 (MV models only)  
THREE WARMER BREWERS

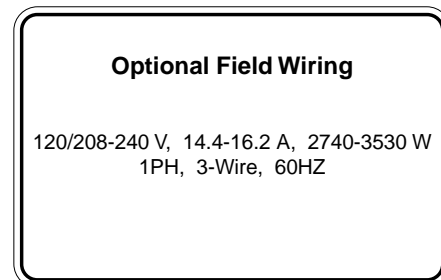

#29710.0003 (DV models only)  
THREE WARMER BREWERS

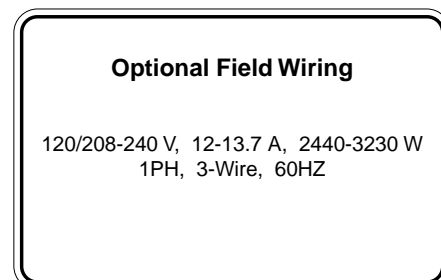

#29710.0004 (DV models only)  
APS BREWERS

## USER NOTICES (CONT.)

### Optional Field Wiring

120 V, 15.0 A, 1800 W  
1PH, 2-Wire, 60HZ

#29710.0005 (DV models only)  
CDBCF-DV BREWERS

### Optional Field Wiring

120/208-240 V, 15.6-17.5 A, 2980-3850 W  
1PH, 3-Wire, 60HZ

#29710.0007 (DV models only)  
NO WARMER BREWERS

### Optional Field Wiring

120/208-240 V, 13.0-15.0 A, 2680-3550 W  
1PH, 3-Wire, 60HZ

#29710.0008 (DV models only)  
CDBC LPTC-DV BREWERS

### Optional Field Wiring

120 V, 16.2 A, 1950 W  
1PH, 2-Wire, 60HZ  
or  
120/208-240 V, 12.7-14.5 A, 2540-3330 W  
1PH, 3-Wire, 60HZ

#29710.0001 (MV models only)  
ONE WARMER BREWERS

#02765.0000

 **CAUTION** WARMERS AND SURFACES ARE HOT

#12364.0000

 **CAUTION** WARMERS AND SURFACES ARE HOT

This equipment is to be installed to comply with the Basic Plumbing Code of the Building Officials and Code Administrators International, Inc. (BOCA) and the Food Service Sanitation Manual of the Food and Drug Administration (FDA).

#00656.0000

# Models CDBC-DV, CDBC-APS DV & CDBC LPTC-DV

## ELECTRICAL REQUIREMENTS

CAUTION - The brewer must be disconnected from the power source until specified in *Initial Set-Up*.

Brewers with an attached cord set require 2-wire, grounded service rated 120 volts ac, 15 amp, single phase, 60 Hz. Requirements for brewers without an attached cord set are as follows:

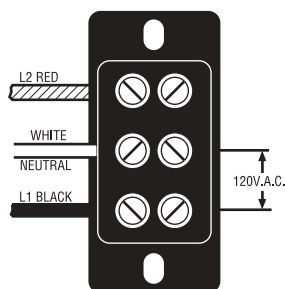

1425W VERSION

Requires 2-wire, grounded service rated 120volts ac, 15 amp, single phase, 60 Hz.

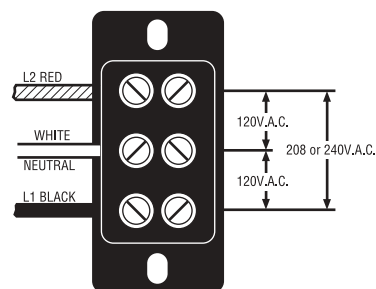

3180W VERSION

Requires 3-wire, grounded service rated 120/240volts ac, 20 amp, single phase, 60 Hz.

## ELECTRICAL HOOK-UP

CAUTION – Improper electrical installation will damage electronic components. The toggle switch is set to operate on a 120 volt, 15 amp service (1425W Version).

1. An electrician must provide electrical service.
2. Determine the available on-site electrical service.
3. Select the desired unit wattage based on the available on-site electrical service.
4. Using a voltmeter, check the voltage and color coding of each conductor at the electrical source.
5. If the brewer is to be connected to 120/208 or 120/240 volts, remove the front access panel beneath the sprayhead and remove the power cord (if provided) from the terminal block.
6. Feed the supply leads through the rear of the brewer.
7. Using the above diagrams, connect the desired electrical service to the field wiring terminal block.
8. If re-wiring the machine for operation on 120/208 or 120/240 volts with a Power Supply Cord, the replacement Power Supply Cord must be UL Listed Flexible Cord Type SO, SJO, SJTO, HSJO or SJOW, No. 12 AWG, 4 Conductor, Rated 90° C. Attachment Plug Cap must be UL Listed, NEMA 14-20P or L14-20P Configuration, Rated 125/250V, 20 AMPS. The Power Supply Cord must be at least 3 feet long and maximum 6 feet long (measured from Strain Relief to end of the Attachment Plug Cap).
9. Before proceeding, verify the voltage at the field wiring terminal block.
10. Set toggle switch on component bracket to the appropriate position (120/208-240V) and replace the access panel.
11. If plumbing is to be hooked up later be sure the brewer is disconnected from the power source. If plumbing has been hooked up, the brewer is ready for *Initial Set-Up*.

# Models CDBC-MV & CDBC-APS MV

## ELECTRICAL REQUIREMENTS

**CAUTION** - The brewer must be disconnected from the power source until specified in *Initial Set-Up*.

### TANK HEATER TERMINAL BLOCK WIRING DIAGRAM (CDBC-MV MODELS)

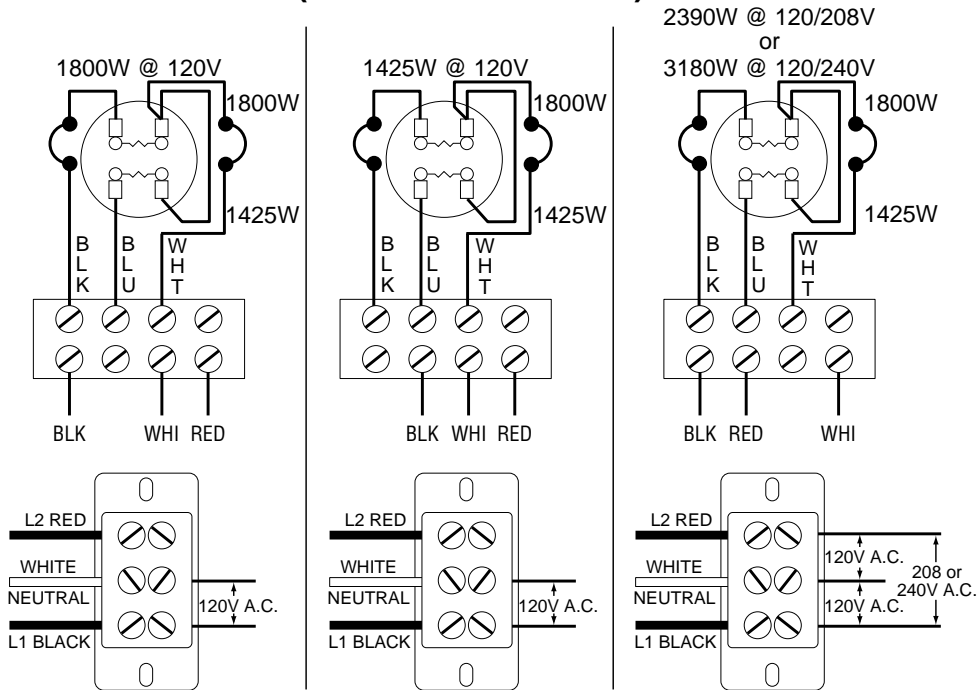

### FIELD WIRING TERMINAL BLOCK DIAGRAM

P1888

#### 1800W VERSION

Requires 2-wire, grounded service rated 120 volts ac, 20 amp, single phase, 60 Hz.

#### 1425W VERSION

Requires 2-wire, grounded service rated 120 volts ac, 15 amp, single phase, 60 Hz.

#### 2390W VERSION

Requires 3-wire, grounded service rated 120/208 volts ac, 20 amp, single phase, 60 Hz.

#### 3180W VERSION

Requires 3-wire, grounded service rated 120/240 volts ac, 20 amp, single phase, 60 Hz.

## ELECTRICAL HOOK-UP

**CAUTION** – Improper electrical installation will damage electronic components. This unit is factory wired for operation on a 120 volt, 15 amp service (1425W Version).

1. An electrician must provide electrical service and verify that the tank heater connections are connected as specified in the above diagram.
2. Determine the available on-site electrical service.
3. Select the desired unit wattage based on the available on-site electrical service.
4. Using a voltmeter, check the voltage and color coding of each conductor at the electrical source.
5. Remove the front panel beneath the sprayhead.
6. Feed the supply leads through the rear panel of the brewer.
7. Using the above diagrams, connect the desired electrical service to the field wiring terminal block and remove the top cover of the brewer to verify the tank heater terminal block connections.
8. The electrical service connections at the field wiring terminal block must agree with the tank heater terminal block connections as specified in the above diagram.
9. Before proceeding, verify the voltage at the field wiring terminal block. Replace the panel and top cover.
10. If plumbing is to be hooked up later be sure the brewer is disconnected from the power source. If plumbing has been hooked up, the brewer is ready for *Initial Set-Up*.

## PLUMBING REQUIREMENTS

These brewers must be connected to a cold water system with operating pressure between 20 and 90 psi (138 and 620 kPa) from a ½" or larger supply line. A shut-off valve should be installed in the line before the brewer. Install a regulator in the line when pressure is greater than 90 psi (620 kPa) to reduce it to 50 psi (345 kPa). The water inlet fitting is ¼" flare.

NOTE - Bunn-O-Matic recommends ¼" copper tubing for installations of less than 25 feet and ⅜" for more than 25 feet from the ½" water supply line. A tight coil of copper tubing in the water line will facilitate moving the brewer to clean the counter top. Bunn-O-Matic does not recommend the use of a saddle valve to install the brewer. The size and shape of the hole made in the supply line by this type of device may restrict water flow.

This equipment must be installed to comply with the Basic Plumbing Code of the Building Officials and Code Administrators International, Inc. (BOCA) and the Food Service Sanitation Manual of the Food and Drug Administration (FDA).

1. Flush the water line and securely attach it to the inlet fitting at the left rear of the brewer.
2. Turn on the water supply.

## INITIAL SET-UP

1. Insert an empty funnel into the funnel rails.
2. Place a decanter with a small amount of water under the funnel.
3. Connect the brewer to the power source.
4. Press the "ON/OFF" switch (indicator glowing).
5. Water will flow into the tank and stop when the tank is filled to its capacity.
6. Wait approximately twenty minutes for the water in the tank to heat to the proper temperature.
7. Place a decanter beneath the faucet and open the faucet handle. Release it when you hear the tank refilling. Empty and place back onto warmer under the funnel.
8. With the "ON/OFF" switch in the "ON" position (indicator glowing), momentarily press and release the "BREW" switch.
9. Allow the cycle to finish and measure the amount of water in the decanter. It should be 64 ounces  $\pm$  2. Refer to the adjustments section of this manual should the volume need to be increased or decreased.

The brewer is now ready for use in accordance with the coffee brewing instructions below.

## COFFEE BREWING

1. Insert a BUNN® filter into the funnel.
2. Pour the fresh coffee into the filter and level the bed of grounds by gently shaking.
3. Slide the funnel into the funnel rails.
4. Place an empty decanter beneath the funnel.
5. Press the "ON/OFF" switch (indicator glowing) then momentarily press and release the "BREW" switch.
6. When brewing is completed, simply discard the grounds and filter.

## CLEANING

1. The use of a damp cloth rinsed in any mild, non-abrasive, liquid detergent is recommended for cleaning all surfaces on Bunn-O-Matic equipment.
2. Check and clean the sprayhead. The sprayhead holes must always remain open.

## OPERATING CONTROLS



P1626

### ON/OFF SWITCH

Pressing the "ON/OFF" switch (indicator glowing) supplies power to the brew station warmer, enables the brew circuit, and energizes the tank refill circuit. Pressing the switch again (indicator not glowing) stops tank refilling and brewing and de-energizes the brew station warmer. Stopping a brew cycle after it has been started will not stop the flow of water into the decanter until the funnel is empty.

NOTE – Hot water will be available at the faucet in a limited amount when the "ON/OFF" switch is in the "OFF" position because the tank will not refill.

### BREW SWITCH

Momentarily pressing and releasing the switch starts a brew cycle when the "ON/OFF" indicator is glowing.

NOTE – The "ON/OFF" indicator must be glowing to initiate and complete a brew cycle.

### ADDITIONAL WARMER SWITCHES

Pressing any additional warmer switch so that the indicator is glowing, supplies power to the associated warmer.

### READY INDICATOR

This indicator glows when the preset temperature has been achieved. The word "NOT" above "READY" will glow in all other instances.

### TEMPERATURE INDICATORS (Feature disabled from the factory – refer to page 8.)

The indicator glows to communicate the brew water temperature. Two indicators will glow when the temperature is between them.



## ADJUSTMENTS & OPTIONAL SETTINGS



P1866

### Setting Brew Temperature

The brewer is factory set to brew at 200°F (95°C). To change this setting, press and hold the "HIDDEN" switch beneath the "®". The word "TEMP" above the "ON/OFF" switch will glow to correspond with the temporary function change of this switch. Repeatedly press and release the "ON/OFF" switch until one of the bank of temperature indicators shows the approximate desired temperature. When two indicators are glowing, the temperature is approximately the number between them.

### Displaying Brew Temperature

The brewer is factory set with the temperature display disabled. To change this setting, press and hold the "ON/OFF" switch and the "HIDDEN" switch beneath the "®" for five seconds, the entire bank of temperature indicators will glow. Release both switches. Pressing and releasing the "ON/OFF" switch will toggle between turning the entire bank of temperature indicators on-or-off, signifying the "ON" or "OFF" condition of this display. Wait for a few seconds, the brewer will maintain this last setting.

### Setting Brew Lockout

The brewer is factory set with the brew lockout disabled. Brew lockout prevents starting a brew cycle if the ready indicator is not glowing. When an attempt at brewing cannot be allowed, the word "NOT" and "LOCKOUT" flash for three seconds to indicate the reason the brew can't begin. To change the condition of the brew lockout, press and hold the "HIDDEN" switch beneath the "®" and momentarily press the "BREW" switch.

### Adjusting Automatic Warmer Shut-Off

The brewer is factory set with this feature disabled. The automatic warmer shut-off de-energizes all warmers after a predetermined time period after the most recent brew cycle. To change the setting, press and hold the "BREW" switch and the "HIDDEN" switch beneath the "®" for five seconds, the entire bank of temperature indicators will flash on-and-off. Release both switches. Pressing and releasing the "BREW" switch will select the number of temperature indicators from none to five. When no indicators are glowing, this feature is disabled and all warmers will be controlled only by their respective switches. When one to five indicators are glowing, it indicates the approximate number of hours of delay before all warmers will be automatically de-energized after the most recent brew cycle.

**IMPORTANT:** The tank must be full and fill solenoid shut off prior to making these adjustments. The sprayhead must be installed when making adjustments.

### Adjusting Brew Volumes

The brewer is factory set to deliver 64 ounces  $\pm$  2 for each brew cycle.

**BREW VOLUME SET-UP:** Use the following steps when the setting is unknown or a different circuit board is being installed.

1. Place an empty funnel in the funnel rails and an empty decanter or graduated vessel beneath the funnel.
2. Press the "ON/OFF" switch (Indicator glowing).

## ADJUSTMENTS & OPTIONAL SETTINGS (CONT.)

3. Press and hold the brew start button until you hear the brew solenoid click on-and-off three times (approximately 5 seconds). Release the button.
4. Allow the cycle to continue until the desired amount of water is dispensed and then turn "OFF" the brewer. The brewer is now set to dispense this amount of water for each subsequent brew cycle.

To **increase** the amount of water for each brew cycle place an empty funnel in the funnel rails and an empty decanter or graduated vessel beneath the funnel. Press the "ON/OFF" switch. Press and hold the "BREW" switch until you hear the solenoid click on-and-off three times (approximately 5 seconds), then release the "BREW" switch. Momentarily press and release the "BREW" switch once for each ounce (approximate) of water to be added to the prior setting and allow the brew cycle to finish.

To **decrease** the amount of water for each brew cycle place an empty funnel in the funnel rails and an empty decanter or graduated vessel beneath the funnel. Press the "ON/OFF" switch. Momentarily press and release the "BREW" switch once for each ounce (approximate) of water to be removed from the existing setting. Press and hold the "BREW" switch until you hear the solenoid click on-and-off three times (approximately 5 seconds), then release the "BREW" switch and allow the cycle to finish.

## TROUBLESHOOTING

A troubleshooting guide is provided to suggest probable causes and remedies for the most likely problems encountered. If the problem remains after exhausting the troubleshooting steps, contact the Bunn-O-Matic Technical Service Department.

- Inspection, testing, and repair of electrical equipment should be performed only by qualified service personnel.
- All electronic components have 120 volt ac and low voltage dc potential on their terminals. Shorting of terminals or the application of external voltages may result in board failure.
- Intermittent operation of electronic circuit boards is unlikely. Board failure will normally be permanent. If an intermittent condition is encountered, the cause will likely be a switch contact or a loose connection at a terminal or crimp.
- Solenoid removal requires interrupting the water supply to the valve. Damage may result if solenoids are energized for more than ten minutes without a supply of water.
- The use of two wrenches is recommended whenever plumbing fittings are tightened or loosened. This will help to avoid twists and kinks in the tubing.
- Make certain that all plumbing connections are sealed and electrical connections tight and isolated.
- This brewer is heated at all times. Keep away from combustibles.

- WARNING –
- Exercise extreme caution when servicing electrical equipment.
  - Unplug the brewer when servicing, except when electrical tests are specified.
  - Follow recommended service procedures.
  - Replace all protective shields or safety notices.

### ***Before troubleshooting this brewer, check for the following:***

#### Control Boards

1. Make sure ribbon cable is properly attached to the control board (ALL PINS INSERTED INTO PLUG).
2. Make sure there is a nylon insulating washer under each screw head that holds the control board to the plastic front end cap. This is important for proper operation.
3. Make sure before servicing brewer that voltage is present at control board.
4. Press any warmer switch or observe if any indicator lights are glowing on the control panel. If so, proceed with testing. If not, check for voltage across pins 1 & 2 of the ten pin J1 connector (black and white wires). If voltage is present, replace the control board. If voltage is not present, check wiring and voltage across terminal block (black and white). Correct the problem and retest before proceeding with testing.

## TROUBLESHOOTING (cont.)

### REFILL CIRCUIT

<u>PROBLEM</u>	<u>PROBABLE CAUSE</u>	<u>REMEDY</u>
Will not fill or refill	1. Power off to brewer	Press warmer switches on control panel to determine if power is ON.
	2. Water shut off	Make sure water is ON.
	3. Display flashing	Brewer has shut down due to malfunction (See Diagnostic Chart in manual, Page 20, or under top lid of brewer).
	4. ON/OFF Switch	Make sure ON/OFF Switch is "ON" and indicator is lit.
	5. Lime build up on Probe	Remove the Level Probe and check for lime deposit on tip. Clean and reinstall.
	6. Refill Valve or Control Board	Disconnect the brewer from the power source and remove wires from refill valve coil. Check for continuity across the terminals of the solenoid coil. If continuity is not present, replace the refill valve (See page 29). If continuity is present, the coil may be stuck closed. Shut water off to brewer. Set the ON/OFF switch to the "OFF" position. Open the faucet and drain water down in the tank until flow stops or slows to a trickle. Attach a voltmeter to the terminals of the refill solenoid. Connect the brewer to the power source. Press the switch "ON". Within five seconds, voltage should be present at the solenoid terminals. If voltage is not present, refer to the wiring diagrams and check the wiring harness.

## TROUBLESHOOTING (cont.)

### REFILL CIRCUIT (cont.)

<u>PROBLEM</u>	<u>PROBABLE CAUSE</u>	<u>REMEDY</u>
Fill or refill does not shut "OFF" (ON/OFF Switch "ON")	<ol style="list-style-type: none"><li>1. Lime build up on probe</li><li>2. Water Level Probe Sensing System</li><li>3. Refill valve or control board</li></ol>	<p>Remove Level Probe and check for lime deposits on tip. Clean and re-install.</p> <p>Disconnect the brewer from the power source. Disconnect the J3 connector from the control board. Check for continuity from the nut on top of the level probe to pin 1 of the plug, continuity should be present. Pull the temperature probe up about an inch from the grommet. Check for continuity from the outside surface of the temperature probe and pin 4 of the plug, continuity should be present. Connect the J3 plug to the control board and proceed to step 3.</p> <p>Press ON/OFF switch to "ON" (Indicator lamp should be lit). If water continuously flows out of air vent tube, disconnect the brewer from the power source. If water flow stops, replace the control board. If water flow does not stop, repair or replace the refill solenoid. (See page 29)</p>
Fill or refill does not shut "OFF" (ON/OFF Switch "OFF")	<ol style="list-style-type: none"><li>1. Refill valve or control board</li></ol>	<p>If water continuously flows out of air vent tube, disconnect the brewer from the power source. If water flow does not stop, repair or replace the refill solenoid. If the valve closes when power is removed, replace the control board. (See page 22)</p>

## TROUBLESHOOTING (cont.)

### HEATING CIRCUIT

#### PROBLEM

---

Water does not heat to proper temperature

**IMPORTANT:** Make sure no temperature tests are taken before the ready light is "ON". Tank temperature must be stabilized before readings are taken.

#### PROBABLE CAUSE

---

1. Display flashing
2. Water not touching temperature probe
3. Water Level Probe Sensing System

#### 4. Temperature Probe

#### 5. Limit Thermostat

#### REMEDY

---

Brewer has shut down due to malfunction (See Diagnostic Chart in manual, Page 20, or under top lid).

Remove temperature probe and grommet. Look into hole on tank lid. Water must be within one inch from top of tank.

Disconnect the brewer from the power source. Disconnect the J3 connector from the control board. Check for continuity from the tank mounting screw where the green wire mounts, to pin 2 of the plug, continuity should be present. Pull the temperature probe up about an inch from the grommet. Check for continuity from the outside surface of the temperature probe and pin 4 of the plug, continuity should be present. Connect the J3 plug to the control board and proceed to step 4.

Remove the probe from the grommet and submerge in a water bath of approximately 70°F(21°C). Connect an ohmmeter to pins 3 and 4 of the J3 connector. At 60°F(16°C) the reading should be 15.3k±2k OHMS, at 70°F(21°C) the reading should be 11.8k ± 2k OHMS, and at 80°F(27°C) the reading should be 9.3k ± 2k OHMS. If the probe is within these parameters, reconnect the J3 plug to the control board.

Disconnect the brewer from the power source. Check for continuity across the limit thermostat terminals. Continuity should be present. If not replace the limit thermostat. (See page 25)

TROUBLESHOOTING (cont.)

HEATING CIRCUIT (cont.)

PROBLEM

PROBABLE CAUSE

REMEDY

Water does not heat to proper temperature (cont.)

IMPORTANT: Make sure no temperature tests are taken before the ready light is "ON". Tank temperature must be stabilized before readings are taken.

6. Tank Heater

Disconnect the brewer from the power source. Check for continuity between the white terminal of the terminal block (or red terminal on 208/240volt models) and the black wire on the relay on the control board (Toggle Switch must be in 120/208-240V position on 208V & 240V models). There should be a low OHM reading. If no continuity is present, check for a wiring problem, then replace the tank heater if no wiring problem is found. (See page 26)

7. Fuse Holder & Fuse (MV models only)

Check fuse and replace if necessary. (See page 31)

8. Thermal Fuse (MV models only)

Check thermal fuse for continuity and replace if necessary. (See page 32)

TROUBLESHOOTING (cont.)

HEATING CIRCUIT (cont.)

PROBLEM	PROBABLE CAUSE	REMEDY
Spitting or excessive steaming (cont.)	1. Lime build up on temperature probe, tank or tank heater	Inspect probe and tank assembly for excessive lime deposits. Delime as required.
	2. Temperature Probe	Remove the probe from the grommet and submerge in a water bath of approximately 70°F(21°C). Connect an ohmmeter to pins 3 and 4 of the J3 connector. At 60°F(16°C) the reading should be 15.3k±2k OHMS, at 70°F(21°C) the reading should be 11.8k ± 2k OHMS, and at 80°F(27°C) the reading should be 9.3k ± 2k OHMS. If the probe is within these parameters, reconnect the J3 plug to the control board.
	3. Control Board	Set the temperature to 200°F(93°C). Let tank temperature stabilize. If temperature in tank is above temperature setting by more than 7°F, replace the control board. (See page 22)
Brewer is making unusual noises	1. Plumbing lines	Plumbing lines should not rest on the counter top.
	2. Water supply	The brewer must be connected to a cold water supply.
	3. Lime build up	Remove the tank lid and clean inside of tank with a deliming agent, if necessary.



## TROUBLESHOOTING (cont.)

### BREWING CIRCUIT

<u>PROBLEM</u>	<u>PROBABLE CAUSE</u>	<u>REMEDY</u>
Brew cycle will not start	1. Display flashing	Brewer has shut down due to malfunction (See Diagnostic Chart in manual, Page 20, or under top lid of brewer).
	2. No water	Water lines and valves to the brewer must be open.
	3. No power or incorrect voltage to the brewer	Check for voltage across the terminals at the terminal block.
	4. ON/OFF switch not in the "ON" position	The indicator lamp must be lit
	5. Low water temperature (Brew lockout is enabled)	Allow brewer to heat until ready lamp is lit, or disable the brew lockout feature. (See page 8)
	6. Water not touching refill probe inside tank	Press ON/OFF switch (indicator must be lit). Brewer will refill until water touches probe inside tank. Water must be in contact with refill probe before brew cycle will start.
	7. Switch panel	Disconnect the brewer from the power source. Disconnect the ribbon connector from the control board. Check for continuity between pins 1 & 2 (An arrow on the connector indicates pin 1). No continuity should be present. Press the BREW switch. Continuity should be present for as long as the switch is held down. If no continuity is present, replace the switch membrane decal. (See page 23)

TROUBLESHOOTING (cont.)

BREWING CIRCUIT (cont.)

PROBLEM

PROBABLE CAUSE

REMEDY

Brew cycle will not start (cont.)

8. Control board or dispense valve

If the switch panel is operating properly, proceed as follows. Attach a voltmeter to the terminals of the dispense solenoid. Connect the brewer to the power source. Turn on the brewer and press the BREW switch. Voltage should be present at the solenoid terminals. If voltage is not present, refer to the wiring diagrams and check the wiring harness. If voltage is present, check for continuity across the terminals of the solenoid coil. If continuity is not present, replace the solenoid (See page 24). If continuity is present, the valve may be stuck closed.

Consistently low beverage level in the dispenser or beverage overflows dispenser

1. Brew volume  
NOTE: Volume adjustments must be made with sprayhead installed.

Set up brewer according to instructions in section **Adjustments-Brew Volumes**. (See page 8) Using a stop watch or second hand, time the length of the brew cycle. Record this time inside the top lid. If service is ever needed again, use the time as reference to determine if time has changed.

2. Lime build up

Inspect the dispense valve and sprayhead for excessive lime deposits. Delime as required.

3. Dispense Valve

Remove dispense valve and clear any obstructions. Rebuild or replace valve if necessary. (See page 24)

TROUBLESHOOTING (cont.)

BREWING CIRCUIT (cont.)

<u>PROBLEM</u>	<u>PROBABLE CAUSE</u>	<u>REMEDY</u>
Dripping from sprayhead	1. Lime build up	Inspect the tank assembly for excessive lime deposits. Delime as required.
	2. Dispense valve	Remove the dispense valve and clear any obstructions. Rebuild or replace the valve if necessary. (See page 24)
Weak beverage	1. Sprayhead	A six-hole stainless steel sprayhead must be used for proper extraction.
	2. Water temperature	Place an empty brew funnel on an empty decanter beneath the sprayhead. Initiate brew cycle and check the water temperature immediately below the sprayhead with a thermometer. The reading must not be less than 195°F (91°C). Adjust the temperature setting to increase the water temperature. Refer to <i>Initial Set-up</i> instructions.
	3. Filter type	BUNN® paper filters must be used for proper extraction.
	4. Coffee grind	A fine drip or grind must be used for proper extraction.
	5. Funnel loading	The BUNN® paper filter must be centered in the funnel and the bed of grounds leveled by shaking gently.

TROUBLESHOOTING (cont.)

BREWING CIRCUIT (cont.)

<u>PROBLEM</u>	<u>PROBABLE CAUSE</u>	<u>REMEDY</u>
Dry coffee grounds remain in the funnel	1. Sprayhead	Make sure sprayhead is present and holes are clear and unobstructed. There should be six separate streams of water coming out of the sprayhead.
	2. Funnel loading	The BUNN® paper filter must be centered in the funnel and the bed of grounds leveled by shaking gently.
Low beverage serving temperature	1. Warmer	Disconnect the brewer from the power source. Remove the warmer plate and turn upside down to expose the warmer terminals. Remove the two wires. Check for continuity across the two warmer terminals. If continuity is not present, replace the warmer element (See page 30). If continuity is present, reconnect the wires to the warmer element. Check for voltage at the warmer terminals. Turn the warmer switch "ON". The indicator light will come on. Voltage should be present at the terminals. If not, disconnect power supply and check wiring and switch.

## DIAGNOSTICS

Intermittent flashing of the bank of temperature indicators, indicates that a fault exists. Count the number of flashes between pauses and use this chart as a guide to investigating the fault.

FLASHES	CAUSE	THINGS TO CHECK
1	Dry Plug - In Fault - Sheath of temperature probe dry for 10 minutes after power-up	Water Pressure (Is water shut "OFF"?) Temperature probe wiring Fill valve wiring, function, & strainer Green wire between tank and circuit board
2	Low Tank Level Fault - Level probe dry for 7 minutes after fill valve is energized	Water pressure (Is water shut "OFF"?) Level probe wiring Temperature probe wiring Fill valve wiring, function, & strainer
3	Low Water Temperature Fault - Sensor in tank is calling for heat for 30 minutes or more	Tank heater wiring & function Temperature probe wiring
4	Tank Sensor Disagreement - Level probe detects water, but dry plug-in probe dry	Temperature probe wiring Level probe wiring Green wire between tank and circuit board
5	Temp Sensor Out-of-Range - High	Sensor not connected to circuit board
6	Temp Sensor Out-of-Range - Low	Sensor wires shorted together or to chassis

## SERVICE

This section provides procedures for testing and replacing various major components used in this brewer should service become necessary. Refer to *Troubleshooting* for assistance in determining the cause of any problem.

**WARNING** - Inspection, testing, and repair of electrical equipment should be performed only by qualified service personnel. The brewer should be unplugged when servicing, except when electrical tests are required and the test procedure specifically states to plug in the brewer.

### COMPONENT ACCESS

**WARNING** - Disconnect the brewer from the power source before the removal of any panel or the replacement of any component.

All components are accessible by the removal of the top cover or warmer housing, front access panel and warmer plate(s).

The top cover is attached with one #4-40 screw.

The front access panel is attached with four #6-32 screws.

Each warmer assembly is attached with three #4-40 screws.

### Contents

Control Board .....	22
Switch Panel .....	23
Dispense Valve .....	24
Limit Thermostat .....	25
Tank Heaters .....	26
Voltage Selector Switch .....	28
Refill Valve .....	29
Warmer Elements .....	30
Fuse Holder and Fuse .....	31
Thermal Fuse .....	32
Wiring Diagrams .....	33

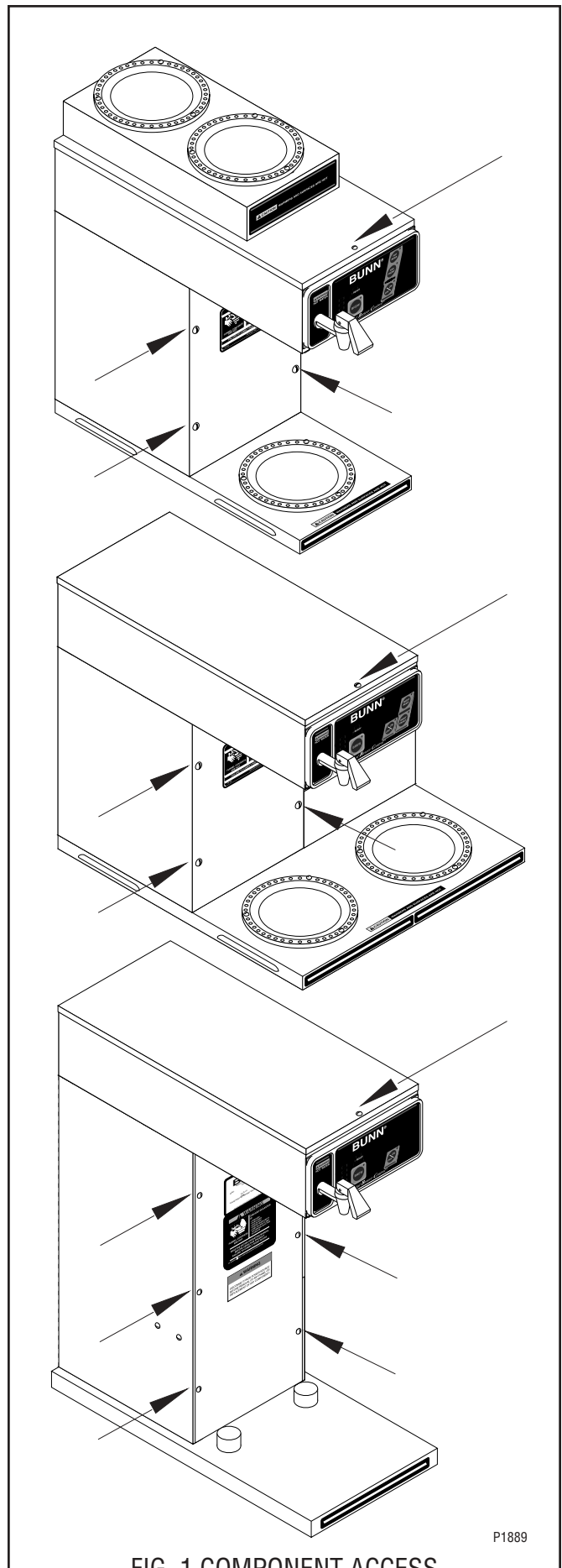

FIG. 1 COMPONENT ACCESS

P1889

## CONTROL BOARD

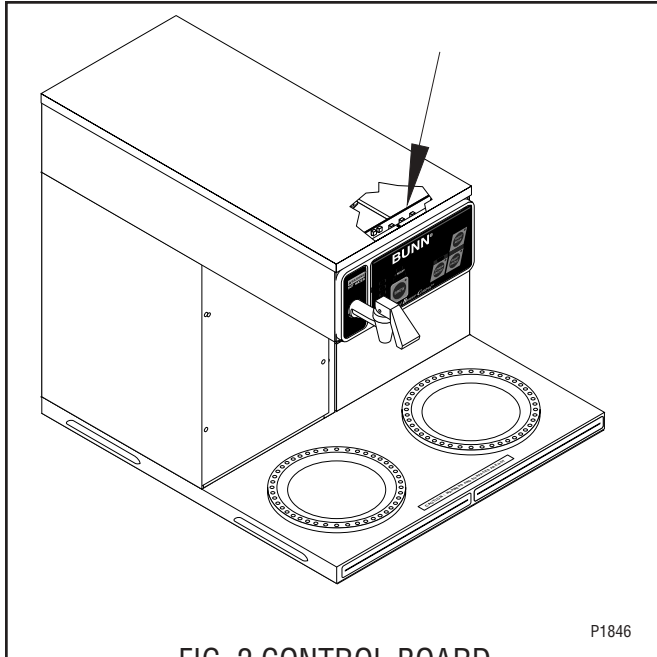

FIG. 2 CONTROL BOARD

### Location:

The Control Board is located inside the top cover behind the front end cap.

### Test Procedures:

The test procedures for the control board will vary depending upon the problems experienced by the brewer. Refer to the Troubleshooting guide beginning on page 10. The troubleshooting guide is divided into three sections, Refill Circuit, Heating Circuit, and Brewing Circuit.

### Removal and Replacement:

1. Disconnect the black wire and blue wire from the relay on the control board.
2. Disconnect the 10-pin connector and the 4-pin connector from the main wiring harness.
3. Disconnect the 11-pin connector from the control panel.
4. Remove the four #6 screws and four nylon washers and the two #4-40 screws securing the control board to the end cap assembly.
5. Install a new control board and secure with the four #6 screws and nylon washers and the two #4-40 screws to the end cap assembly.  
NOTE: The four nylon washers must be installed under the heads of the four #6 screws to prevent a possible shorting of the control board circuits.
6. Connect the 11-pin connector from the control panel.
7. Connect the 10-pin connector and the 4-pin connector from the main wiring harness.
8. Connect the blue wire and black wire to the relay on the control board.
9. Refer to *Adjustments and Optional Settings* (See page 9) to program the new control board.

## SERVICE (cont.)

### SWITCH PANEL

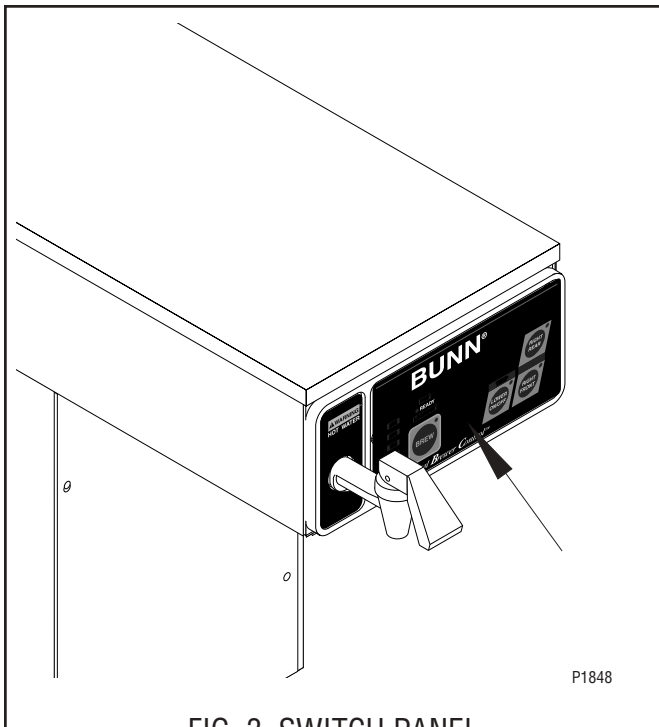

FIG. 3 SWITCH PANEL

#### Location:

The Switch Panel is located in the front of the hood.

#### Test Procedures:

The test procedures for the switch panel and the control board will vary depending upon the problems experienced by the brewer. Refer to the Troubleshooting guide beginning on page 10. The troubleshooting guide is divided into three sections, Refill Circuit, Heating Circuit, and Brewing Circuit.

#### Removal and Replacement:

1. Disconnect the 11-pin connector to the switch panel from the control board.
2. Remove the four #6 screws, nylon washers and the two #4-40 screws securing the control board to the end cap assembly and set aside.
3. Gently pry the switch panel from the end cap assembly.
4. Remove any adhesive that remains on the end cap.
5. Remove the adhesive backing from the new switch panel. Insert the ribbon connector through the slot in the end cap and apply the switch panel to the end cap.
6. Install the control board to the back side of the end cap using the four #6 screws, nylon washers and the two #4-40 screws to the end cap assembly.  
NOTE: The four nylon washers must be installed under the heads of the four #6 screws to prevent a possible shorting of the control board circuits.
7. Reconnect the 11-pin connector from the switch panel to the control board making sure every pin on the control board is inserted into the ribbon cable plug.



## SERVICE (cont.)

### DISPENSE VALVE

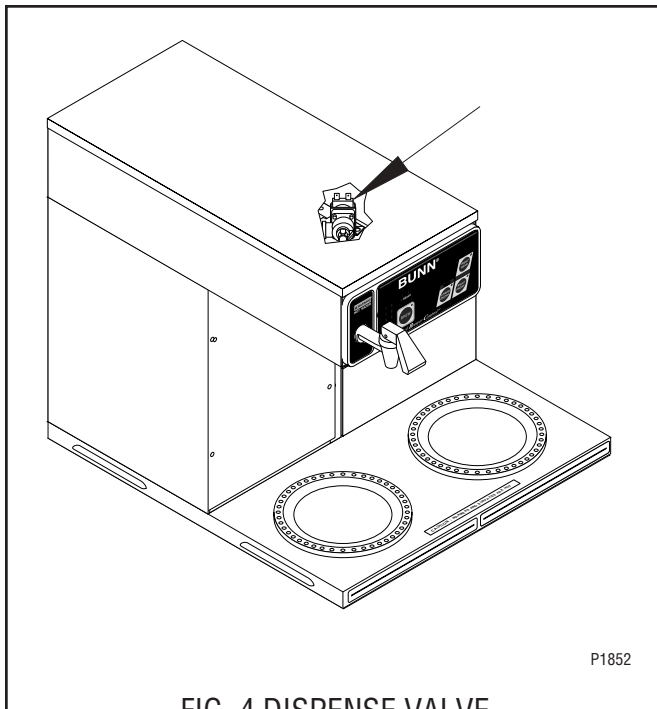

FIG. 4 DISPENSE VALVE

#### Location:

The dispense valve is located inside the top cover behind the front end cap.

#### Test Procedures:

1. Disconnect the brewer from the power source.
2. Check the water level in the tank to confirm that it is within 1/2" from the top of the tank.
3. Connect the brewer to the power source. If the brewer has been set for brewer temperature lock-out, this feature must be disabled. See Page 9 for procedure.
4. Check the dispense valve for coil action. Place the ON/OFF switch in the "ON" position, press and release the BREW switch. Listen carefully in the vicinity of the dispense valve for a "clicking" sound as the coil magnet attracts and repels the plunger.
5. Disconnect the brewer from the power source.

If the sound is heard as described, there may be a blockage in the dispense valve or the water line to the sprayhead. Remove the dispense valve and inspect for wear, and remove waterborne particles.

If the sound is not heard as described, proceed to #6.

6. Connect the voltmeter lead ends to the dispense valve coil terminals. Connect the brewer to the power source. Brewer temperature lockout must be disabled. Place "ON/OFF" Switch in the "ON" position. Press and release the brew switch. The indication must be 120 volts ac.
7. Disconnect the brewer from the power source.

If voltage is present as described, but no coil action is observed, nor "clicking" heard, dispense valve is defective. Replace valve and test again to verify repair. If voltage is not present as described, refer to *Wiring Diagrams* and check the brewer wiring harness. Also check the control board for proper operation. See Pages 22 and 23.

#### Removal and Replacement:

1. Disconnect wires from the dispense valve.
2. Drain enough water from the tank so the dispense valve is above the water level.
3. Remove water lines from the dispense valve.
4. Remove the two #8-32 nuts securing the dispense valve to the sprayhead panel.
5. Install a new dispense valve using the two #8-32 nuts.
6. Reconnect water lines to the dispense valve and secure in place with clamps.
7. Refer to FIG. 5 when reconnecting wires.

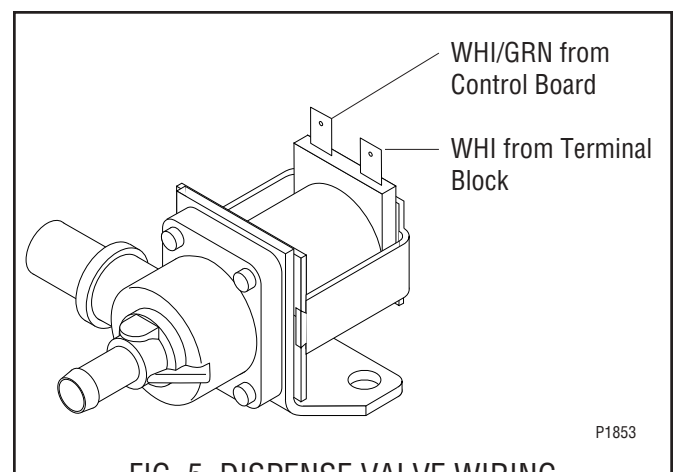

FIG. 5 DISPENSE VALVE WIRING

## SERVICE (cont.)

### LIMIT THERMOSTAT

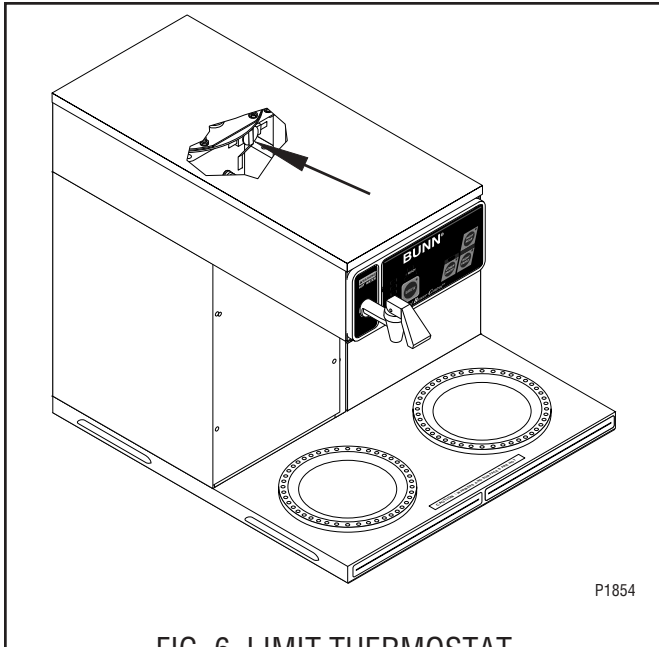

FIG. 6 LIMIT THERMOSTAT

#### Location:

The limit thermostat is located inside the front access panel on the front side of the tank.

#### Test Procedures:

1. Disconnect the brewer from the power source.
2. Disconnect the blue and black wires from the limit thermostat.
3. With an ohmmeter, check for continuity across the limit thermostat terminals.

If continuity is present as described, the limit thermostat is operating properly.

If continuity is not present as described, replace the limit thermostat.

#### Removal and Replacement:

1. Remove the black and blue wires from limit thermostat terminals.
2. Carefully slide the limit thermostat out from under the retaining clip and remove limit thermostat.
3. Carefully slide the new limit thermostat into the retaining clip.
4. Refer to FIG. 7 when reconnecting the wires.

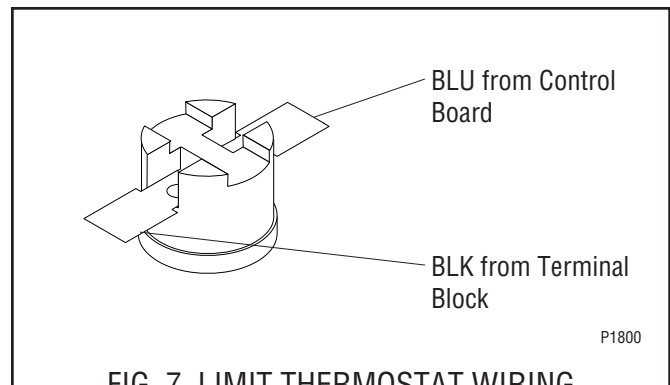

FIG. 7 LIMIT THERMOSTAT WIRING

## SERVICE (cont.)

### TANK HEATERS

#### Location:

The tank heaters are located inside the tank and secured to the tank bottom.

#### DV models only Test Procedures :

1. Disconnect the brewer from the power source.
2. With a voltmeter, check voltage across the white wire from the terminal block and black wire from the control board. Connect brewer to the power source. The indication must be 120 volts ac.
3. Disconnect the brewer from the power source.
4. Check voltage across the red wire from the terminal block and black wire from the control board. Connect brewer to the power source. The indication must be 240 volts ac.
5. Disconnect the brewer from the power source.

If voltage is present as described, proceed to #6

If voltage is not present as described, refer to the *Wiring Diagrams* and check wiring harness.

6. Disconnect the black and blue wires or the red and brown wires from the tank heater terminals.
7. Check for continuity across tank heater terminals.

If continuity is present as described, reconnect the wires, the tank heater is operating properly.

If continuity is not present as described, replace the tank heater.

NOTE- If the tank heater remains unable to heat, remove and inspect heater for cracks in the sheath.

#### MV models only Test Procedures:

1. Disconnect the brewer from the power source.
2. With a voltmeter, check voltage across the white or red wire from the terminal block and black wire from the control board. Connect brewer to the power source. The indication must be 120 volts ac for two wire 120 volt models or 208-240 volts ac for three wire 120/208-240 volt models.
3. Disconnect the brewer from the power source.

If voltage is present as described, proceed to #4

If voltage is not present as described, refer to the *Wiring Diagrams* and check wiring harness.

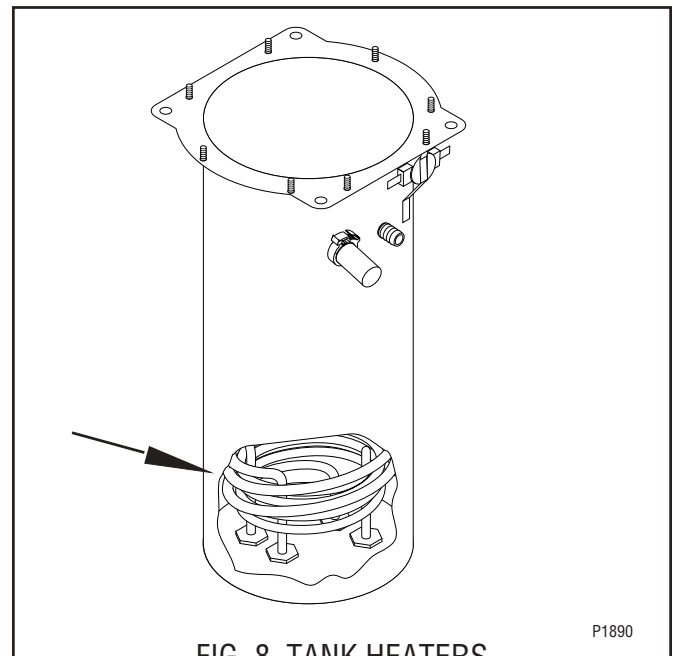

FIG. 8 TANK HEATERS

4. Disconnect the black wire and the white wire or red wire from the tank heater terminals.
5. Check for continuity across tank heater terminals.

If continuity is present as described, reconnect the wires, the tank heater is operating properly.

If continuity is not present as described, replace the tank heater.

NOTE- If the tank heater remains unable to heat, remove and inspect heater for cracks in the sheath.

#### All models Removal and Replacement:

1. Remove the top cover or top warmer housing and front access panel as previously described.
2. Disconnect the vent hose from the top of the tank by pulling the elbow fitting from the grommet in the top of the tank lid.
3. Drain water from the tank.
4. Disconnect the water supply tube to the dispense valve from the side of the tank.
5. Disconnect the water supply tube to the solenoid valve from the bottom of the tank.
6. On brewers with faucet, disconnect the outlet water line to the faucet from the side of the tank.
7. Disconnect the temperature probe from the top of the tank by pulling the probe from the grommet in the top of the tank lid.
8. Disconnect the pink wire from the level probe.
9. Disconnect the green wire from the top of the tank.
10. Disconnect the limit thermostat from the side of the tank.

SERVICE (cont.)

TANK HEATERS (cont.)

11. Disconnect the two white wires from the tank warmer blanket.
12. Disconnect the black, white and blue wires from the tank heater terminals. DV models only, disconnect the brown and red wires from tank heater terminals.
13. Remove the four #8-32 nuts securing the tank to the mounting brackets and remove the tank assembly.
14. Remove the eight #8-32 nuts securing the tank lid to the tank.
15. Remove the two hex nuts securing the tank heater to the bottom of the tank. Remove tank heater with gaskets and discard.
16. Install new tank heater with gaskets to the bottom of the tank and secure with two hex nuts.
17. Install tank assembly onto mounting brackets and secure in place with four #8-32 nuts.
18. Install tank lid and secure in place with eight #8-32 nuts.
19. Connect the two white wires of the tank warmer blanket.
20. Connect the limit thermostat to the front of the tank assembly.
21. Connect the green wire to the tank mounting bracket using #8-32 nut.
22. Connect the pink wire to the level probe.
23. Insert the temperature probe through the grommet in the tank lid.
24. Install the elbow fitting of the vent hose into the grommet in the tank lid.
25. On brewers with faucet, connect the outlet water line of the faucet to the side of the tank and secure with clamp.
26. Connect the water supply tube from the solenoid to the bottom of the tank and secure with clamp.
27. Connect the water supply tube from the dispense valve to the side of the tank and secure with clamp.
28. DV models only - Refer to the *Wiring Diagrams* when reconnecting the tank heater wires.  
MV models only - Refer to FIG. 9 when reconnecting the tank heater wires.
29. Install access panels and covers and refer to *Initial Set-up* for refill and operation.

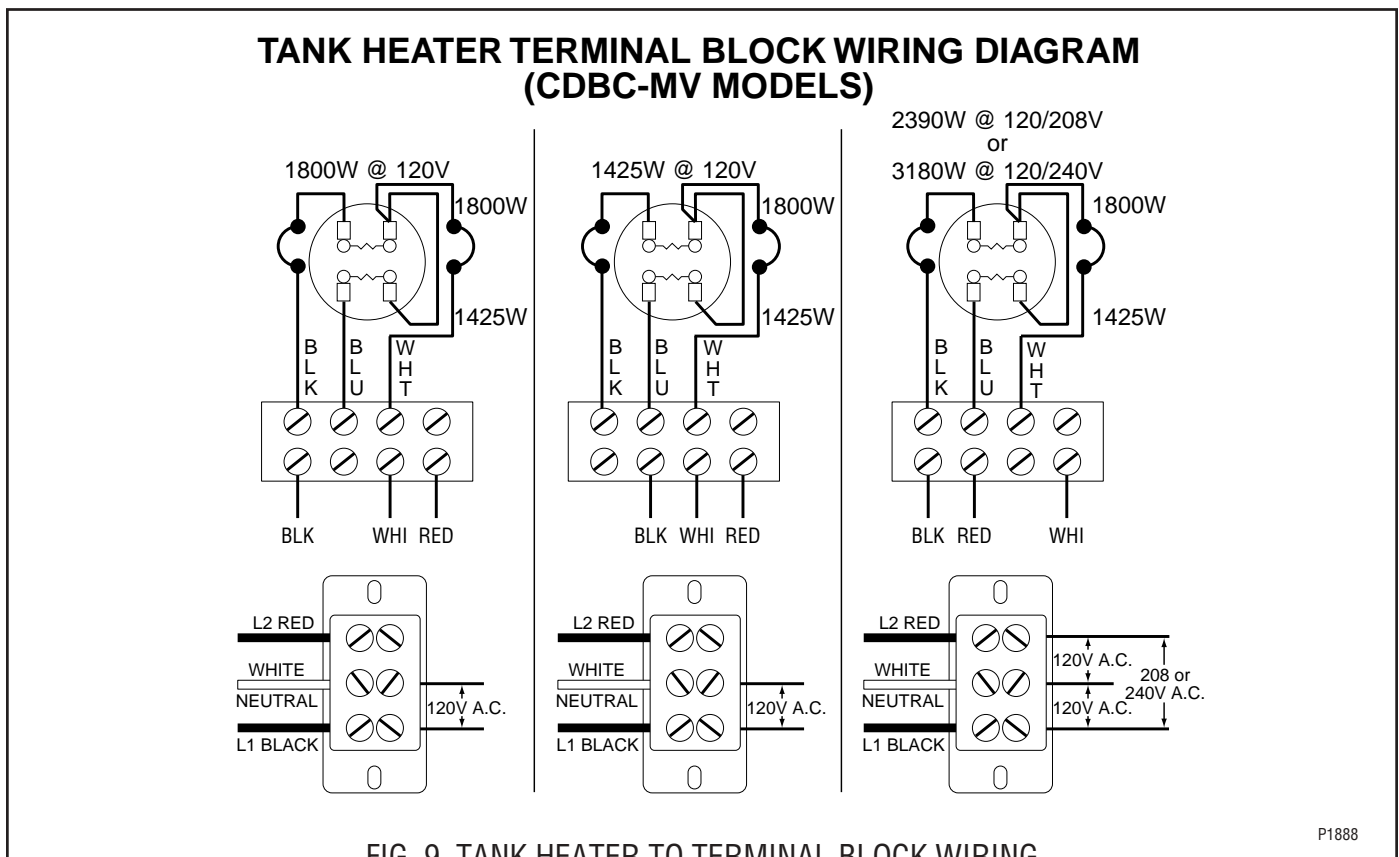

P1888

VOLTAGE SELECTOR SWITCH - DV models only

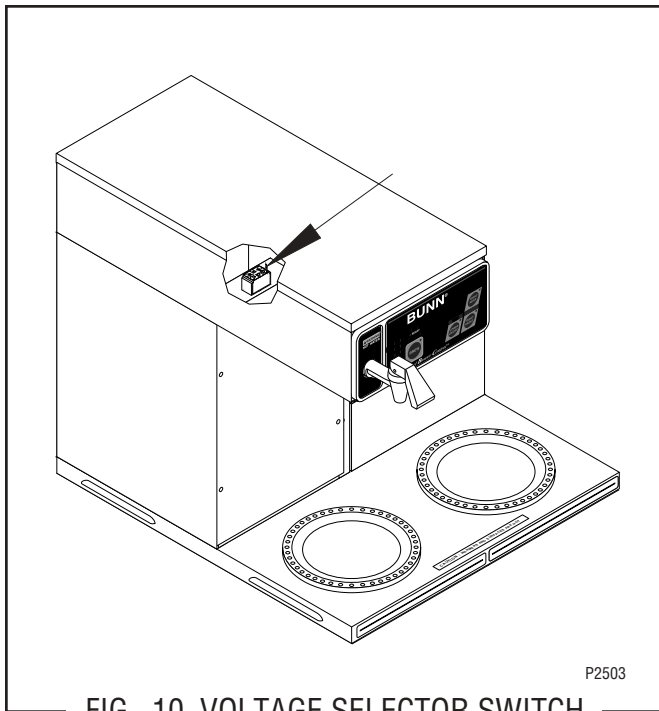

FIG. 10 VOLTAGE SELECTOR SWITCH

Location:

The voltage selector switch is located on the component mounting bracket behind the front access panel.

Test Procedure:

1. Disconnect the brewer from the power source.
2. With the voltage selector switch in the 120V position, connect a voltmeter between the black terminal of the terminal block and the center terminal of the selector switch.
3. Connect the brewer to the power source. The indication must be 120 volts ac.
4. Move the voltage selector switch to the 120/208-240V position, the indication must be 240 volts ac.
5. Disconnect the brewer from the power source.

If voltage is present as described, proceed to #6.  
If voltage is not present as described, refer to the *Wiring Diagrams* and check the brewer wiring harness.

6. Disconnect the white and blue wires from the selector switch. With the selector switch in the 120V position, check for continuity between the two empty terminals of the switch.

7. Disconnect the white/violet wire from the selector switch. With the selector switch in the 120/208-240V position, check for continuity between the center terminal and the white/violet wire terminal.

If continuity is present as described, the dual voltage selector switch is operating properly.

If continuity is not present as described, replace the dual voltage selector switch.

Removal and Replacement:

1. Disconnect the brewer from the power source.
2. Disconnect the three wires from the selector switch.
3. Remove the switch mounting nut from the under side of component mounting bracket; remove switch from bracket.
4. Install new switch in component mounting bracket and secure with mounting nut.
5. Refer to FIG. 11 when reconnecting wires to the switch.

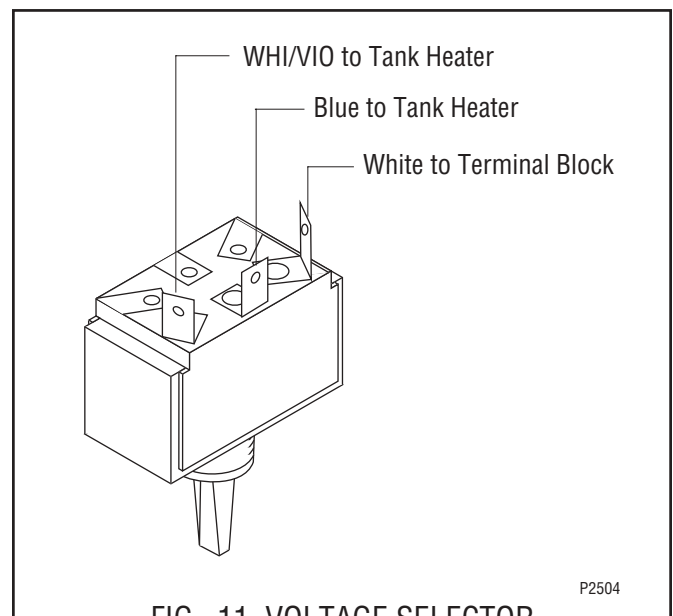

FIG. 11 VOLTAGE SELECTOR SWITCH TERMINALS

## SERVICE (cont.)

### REFILL VALVE

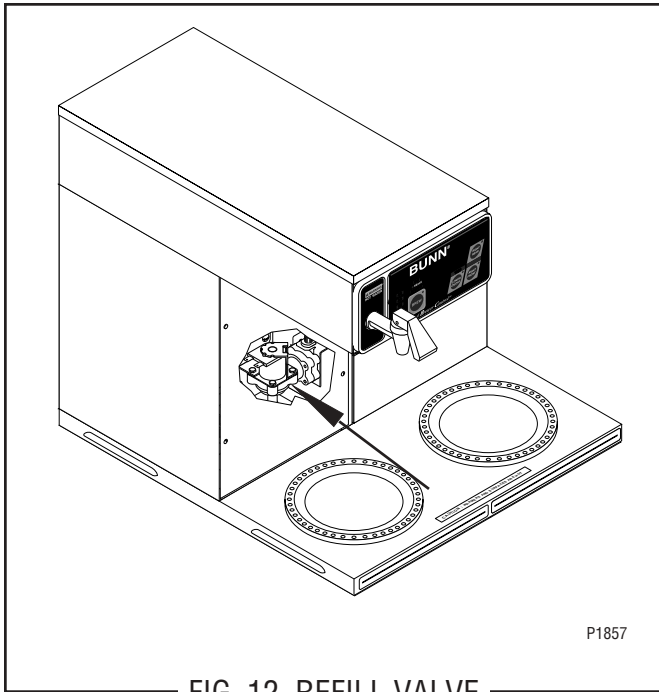

FIG. 12 REFILL VALVE

#### Location:

The refill valve is located inside the trunk on the lower center part of the component bracket.

#### Test Procedures:

1. Disconnect the brewer from the power source.
2. Disconnect the white and white/blue wires from the refill valve. Set the "ON/OFF" switch in the "ON" upper position.
3. With a voltmeter, check the voltage across the coil wires. Connect the brewer to the power source. The indication must be 120 volts ac for two wire 120 volt models and three wire 120/208 and 120/240 volt models.
4. Disconnect the brewer from the power source.

If voltage is present as described, proceed to #5.  
If voltage is not present as described, refer to *Wiring Diagrams* and check brewer wiring harness.

5. Check for continuity across the refill valve coil terminals.

If continuity is present as described, reconnect the white and white/blue wires from the circuit board.

If continuity is not present as described, replace the refill valve.

6. Check the refill valve for coil action. Connect the brewer to the power source. With "ON/OFF" switch in the "ON" upper position press start switch and listen carefully in the vicinity of the refill valve for a "clicking" sound as the coil magnet attracts.
7. Disconnect the brewer from the power source.

If the sound is heard as described and water will not pass through the refill valve, there may be a blockage in the water line before the refill valve or, the solenoid valve may require inspection for wear, and removal of waterborne particles.

If the sound is not heard as described, replace the refill valve.

#### Removal and Replacement:

1. Remove both wires from the refill valve.
2. Turn off the water supply to the brewer and drain the tank.
3. Disconnect the water lines to and from the refill valve.
4. Remove the two 1/4"-20 screws securing the refill valve mounting bracket to the component bracket. Remove bracket and valve as an assembly.
5. Using two 1/4"-20 screws install the new refill valve and bracket to the component bracket.
6. Securely fasten the water lines to and from the valve.
7. Refer to FIG. 13 when reconnecting the wires.
8. Install access panels and covers and refer to *Initial Set-up* for refill and operation.

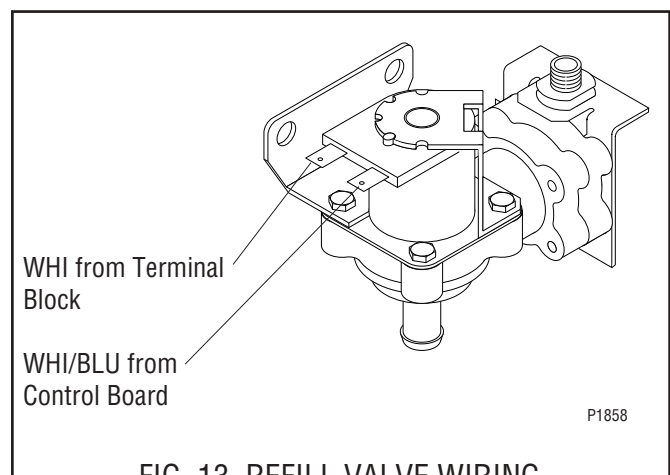

FIG. 13 REFILL VALVE WIRING



## SERVICE (cont.)

### WARMER ELEMENT(S)

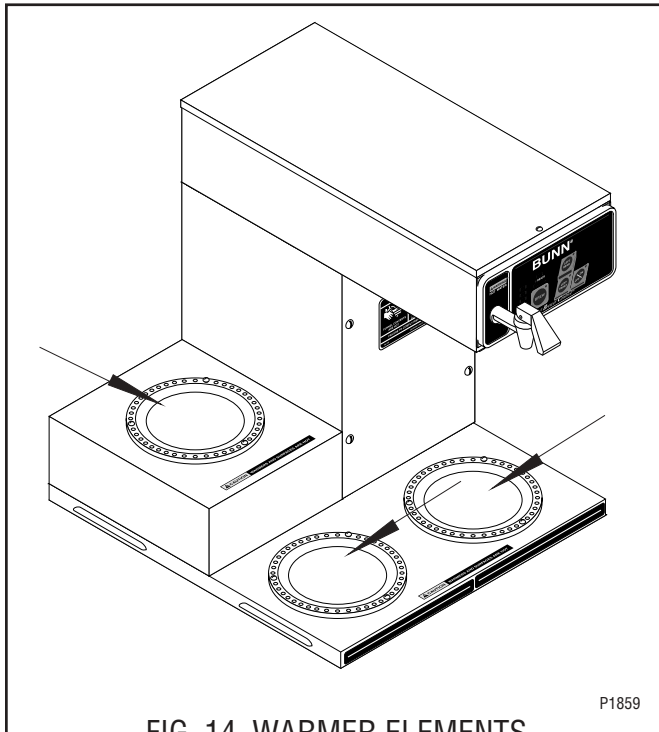

FIG. 14 WARMER ELEMENTS

#### Location:

The warmer element(s) is located under the warmer plate.

#### Test Procedures:

1. Disconnect the brewer from the power source.
2. With a voltmeter, check voltage across the two wires at the warmer element with the "ON/OFF" switch in the "ON" position. Connect the brewer to the power source. The indication must be 120 volts ac for two wire 120 volt models and three wire 120/208 and 120/240 volt models.
3. Disconnect the brewer from the power source.

If voltage is present as described, proceed to #4.  
If voltage is not present as described, refer to *Wiring Diagrams* and check brewer wiring harness.

4. Check the continuity across the two terminals on the warmer element.

If continuity is present as described, reconnect the two wires to the warmer element.

If continuity is not present as described, replace the warmer element.

#### Removal and Replacement:

1. Remove the three #4-40 screws securing the warmer assembly to the brewer.
2. Lift the warmer assembly from the brewer.
3. Disconnect the two wires from the warmer element terminals.
4. Remove the two #8-32 nuts securing the warmer element to the warmer plate.
5. Securely install new warmer element.
6. Reconnect the two wires to warmer element terminals.
7. Securely install warmer assembly on the brewer.
8. Refer to the *Wiring Diagrams* when reconnecting the wires.

## SERVICE (cont.)

### FUSE HOLDER/FUSE ASSEMBLY MV models only

#### Removal and Replacement:

1. Remove the cap from the holder.
2. Remove fuse from the fuse holder and discard.
3. Install new 20 amp fuse in the holder.
4. Reinstall fuse holder cap.

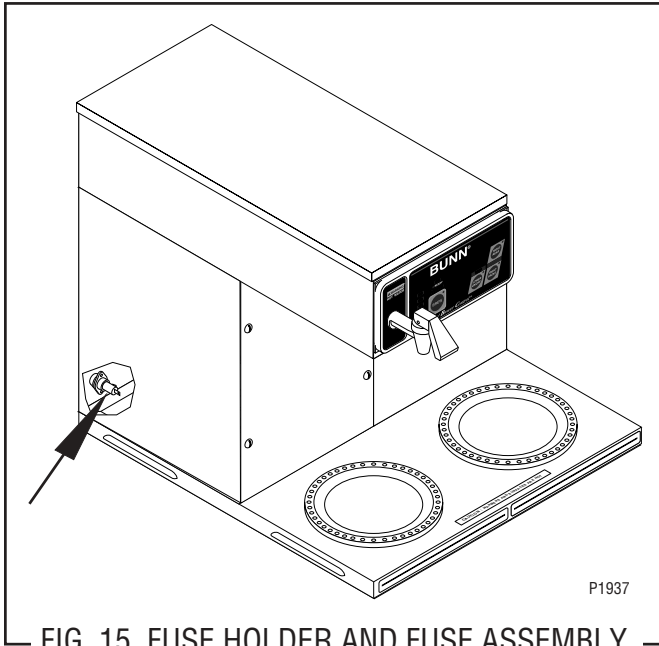

FIG. 15 FUSE HOLDER AND FUSE ASSEMBLY

#### Location:

The fuse holder and fuse assembly is located on the left rear side of the brewer.

#### Test Procedures:

1. Disconnect the brewer from the power source.
2. Remove the cap from the fuse holder and remove the fuse.
3. With an ohmmeter, check for continuity through the fuse.

If continuity is present as described, reinstall the fuse, the fuse is operating properly.

If continuity is not present as described, replace the fuse.



## SERVICE (cont.)

### THERMAL FUSES MV models only

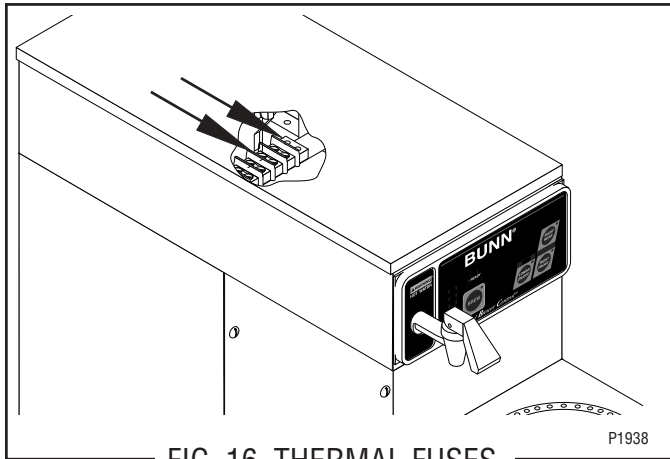

FIG. 16 THERMAL FUSES

#### Location:

The thermal fuses are included with the wiring harness from the tank heater terminals to the terminal block located inside the top cover.

#### Test Procedures:

1. Disconnect the brewer from the power source.
2. Disconnect the thermal fuse from the right tank heater terminal and tank heater terminal block or the thermal fuse from the left tank heater terminal and the tank heater terminal block.
3. With an ohmmeter, check for continuity across the thermal fuse terminals.

If continuity is present as described, the thermal fuse is operating properly.

If continuity is not present as described, replace the thermal fuse.

#### Removal and Replacement:

1. Disconnect the thermal fuse wiring harness from the right tank heater terminal tank heater terminal block or the thermal fuse from the left tank heater terminal and the tank heater terminal block.
2. Remove the wiring harness and discard.
3. Connect new wiring harness to right tank heater terminal tank heater terminal block or the left thermal fuse to the left tank heater terminal and the tank heater terminal block.
4. Refer to Fig. 16 when reconnecting the thermal fuse wiring harness.

# SCHEMATIC WIRING DIAGRAM CDBC DV

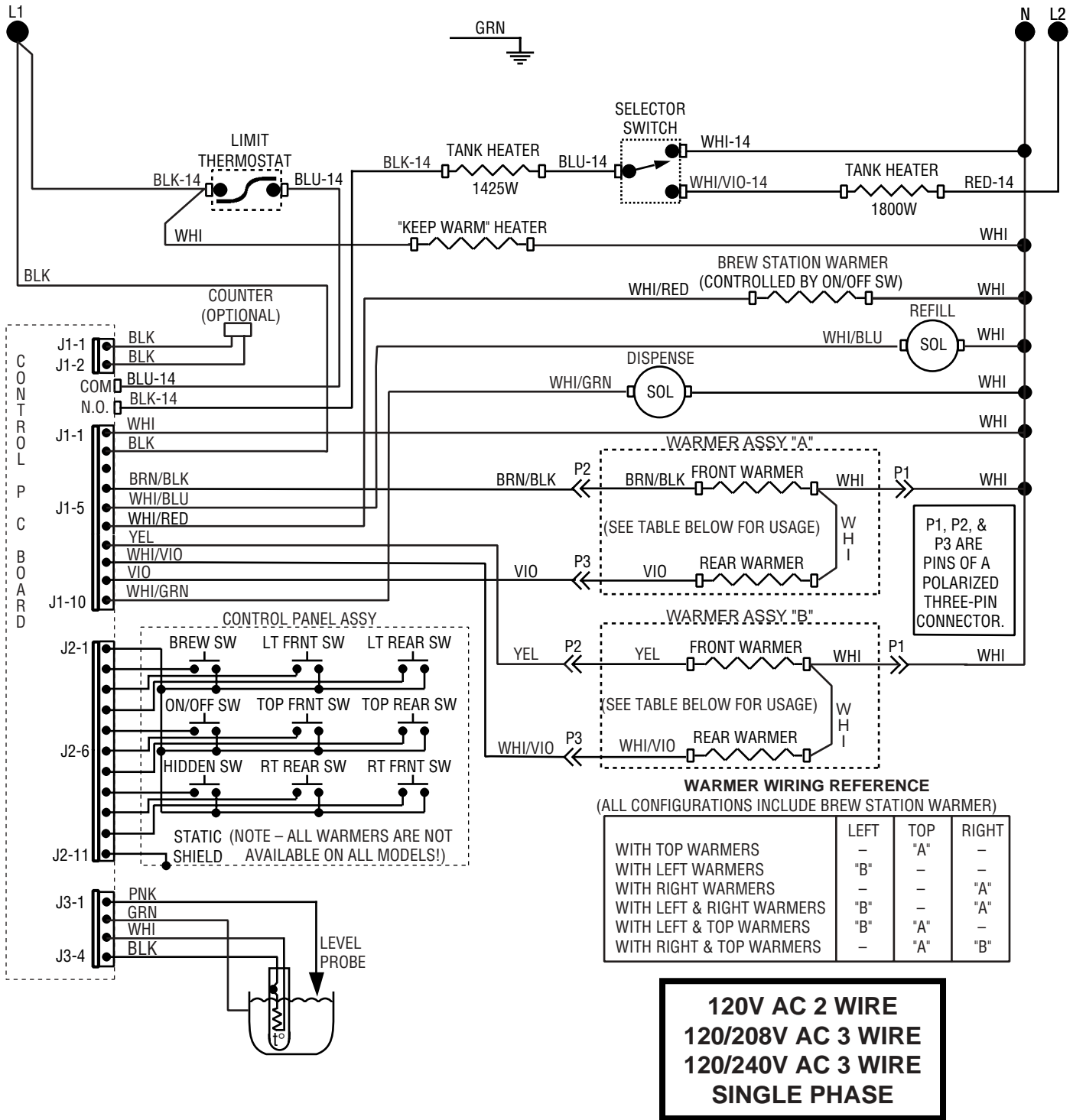

# SCHEMATIC WIRING DIAGRAM CDBC APS-DV CDBC F APS/TC/LPTC-DV

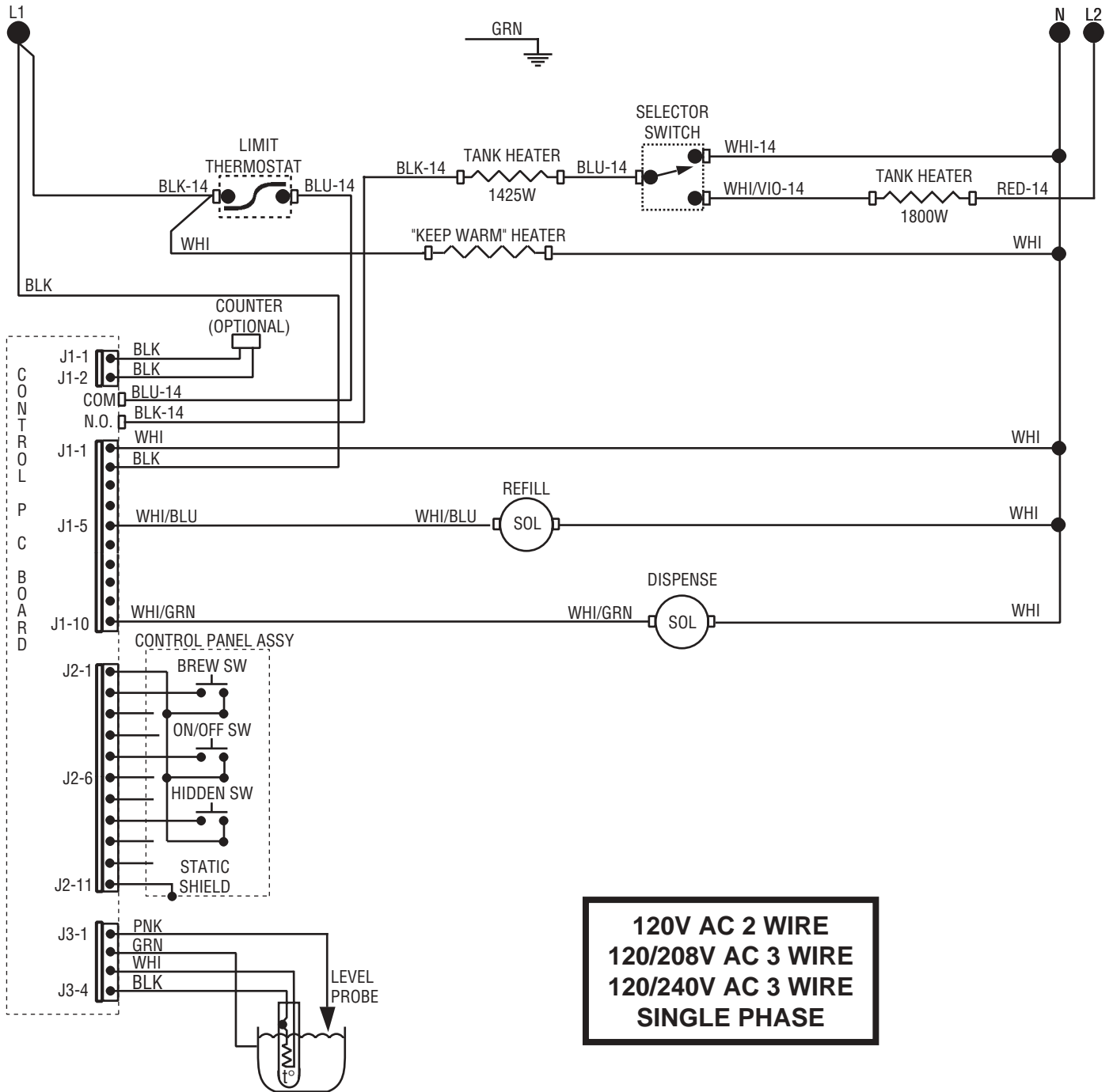

# SCHEMATIC WIRING DIAGRAM CDBC MV

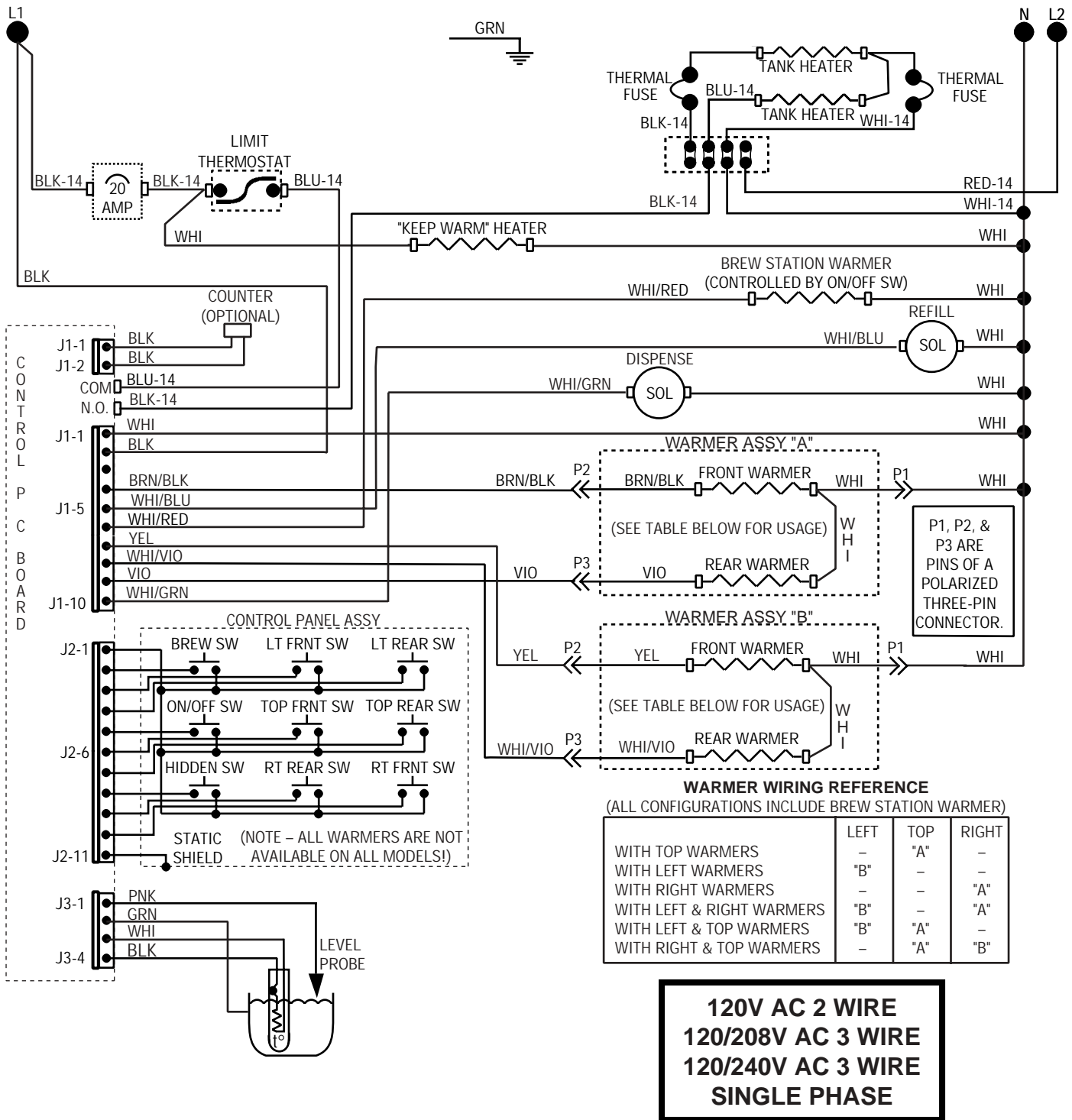

# SCHEMATIC WIRING DIAGRAM CDBC - APS MV

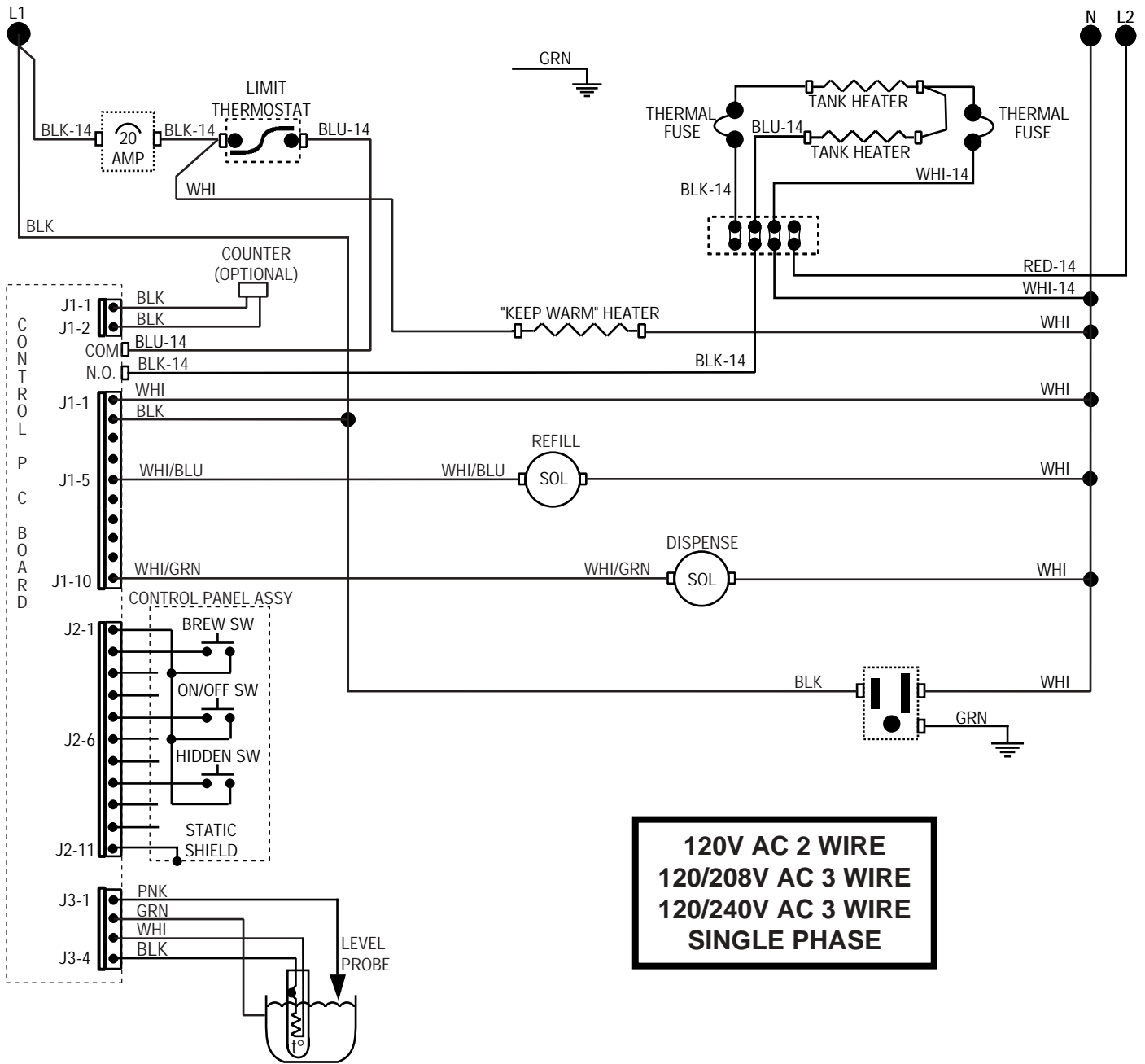

**120V AC 2 WIRE  
120/208V AC 3 WIRE  
120/240V AC 3 WIRE  
SINGLE PHASE**